

SALON DE

CHANNARA PUBLIC LIBRARY

14 NOV 1956

MADRAS

# SOUTHERN RAILWAYS

*Magazine*

496

4-56

REGISTRAR OF BOOKS  
MADRAS  
1956

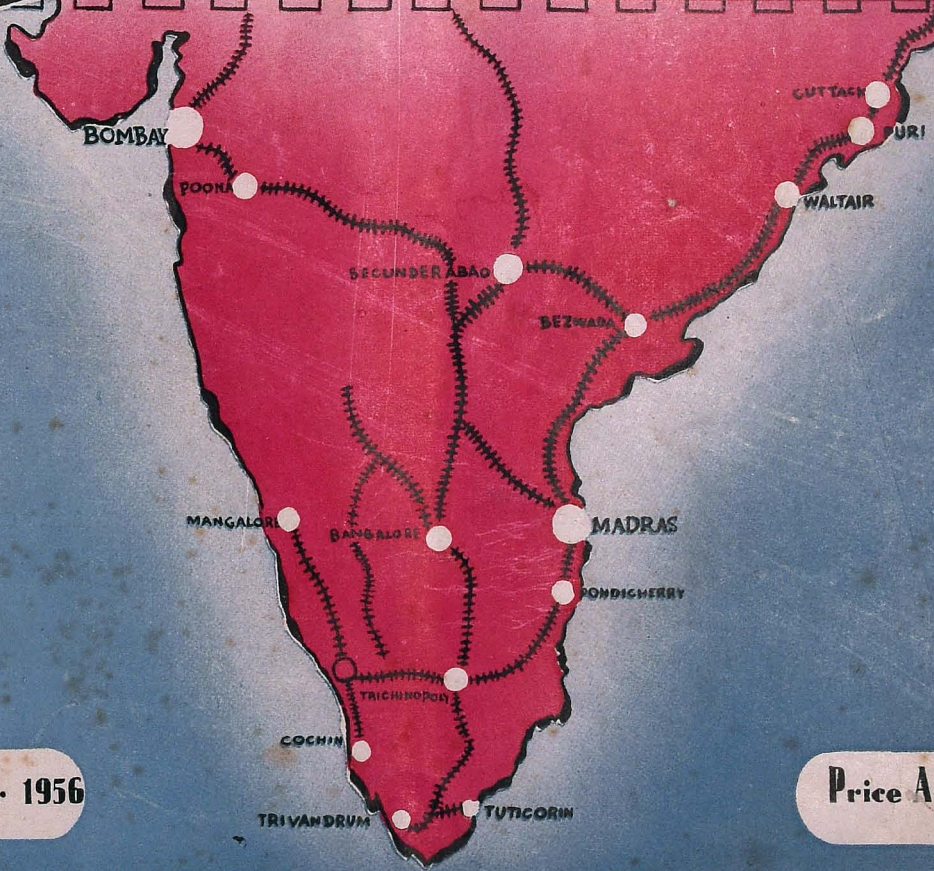
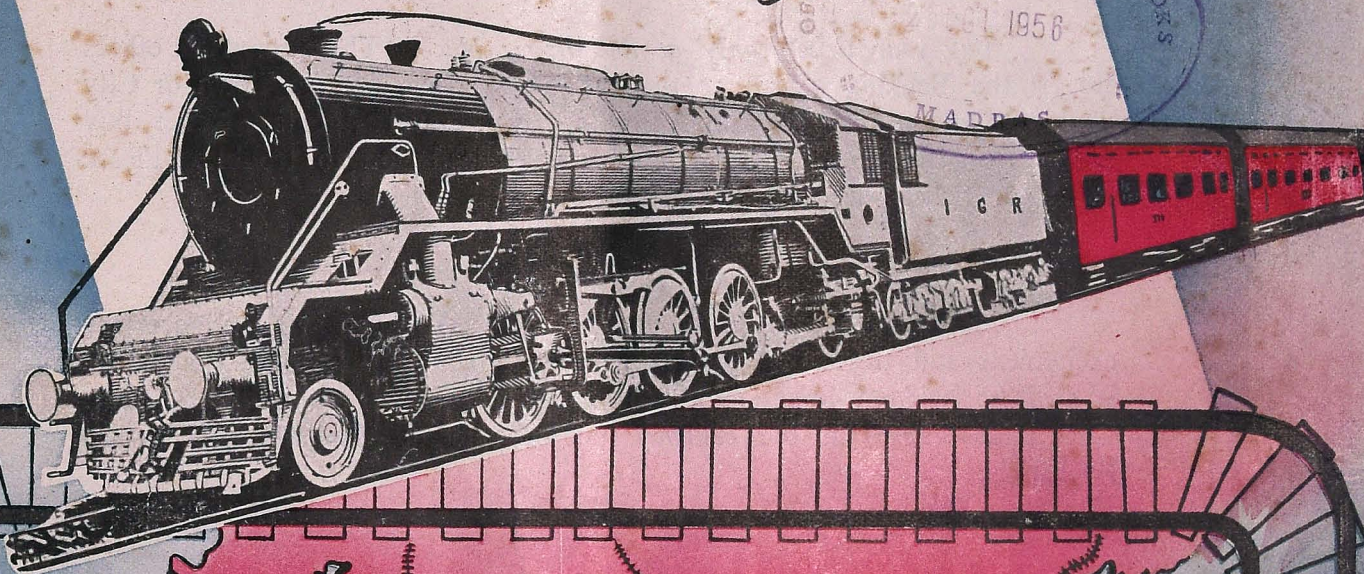

October 1956

Price As. 4/-

# IN YOUR OWN INTERESTS

## HOW TO PURCHASE TICKETS

*Buy your tickets only at the proper place.* The authorised offices are (i) the Booking offices at the railway stations, (ii) the Town or City Booking Offices, (iii) the out-Agencies, (iv) Travel Agents. Never buy tickets from any other source as that may lead you to trouble. Please note that tickets are not transferable.

*Buy your tickets in the proper time.* You can avoid unnecessary excitement and trouble if you come to the station in good time, that is at least half an hour before the scheduled departure of your train. The Time Tables of the Railway are on sale at Booking Offices and Bookstalls.

*Buy your tickets in the proper manner.* Queue up at the Booking Window and you can get your ticket easier and quicker than by crowding at the counter.

By handing in the *exact fare in good coins or currency* you get the ticket easier and quicker, and save for yourself and the Booking Clerk time and trouble.

Check up your ticket and money before leaving the counter and draw the attention of the Booking Clerk to any discrepancy you may notice.

*( Inserted in the interests of Travelling Public )*

*the source of  
their strength  
is **PRESSED STEEL***

The strength of steel pays valuable dividends. In length of service. In fewer running repairs and maintenance. In longer operative life. In overall economy. From the Scottish factory of Pressed Steel Company Limited, steel wagons *many thousands strong* pass year by year to the railways of the world . . . for a hard and long life of service.

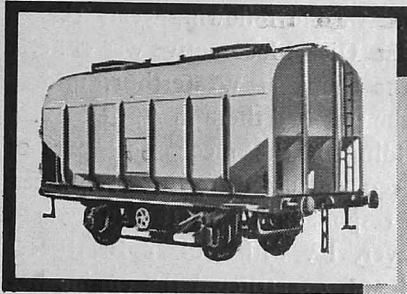

20-ton capacity Bulk Grain Van to the order of British Railways.

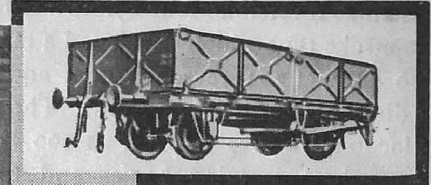

F.J.S. Low-sided Open type Wagon as used by Queensland Government Railways, Australia.

*their  
service  
is world  
wide*

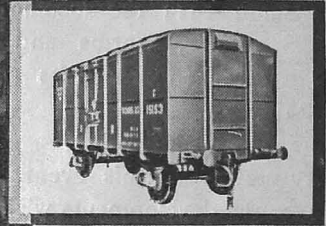

Broad gauge covered Wagon type C.R. as used by Indian Railways.

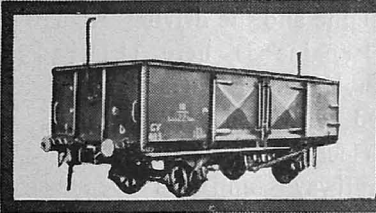

22-ton G.Y. type Wagon as used by Victoria Government Railways, Australia.

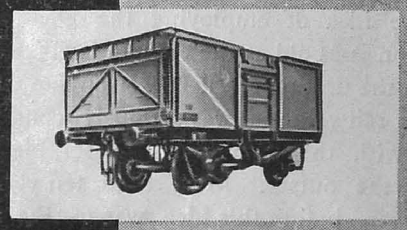

16-ton all steel Mineral Wagon, 50,000 of which have already been built in our Paisley works to the order of British Railways.

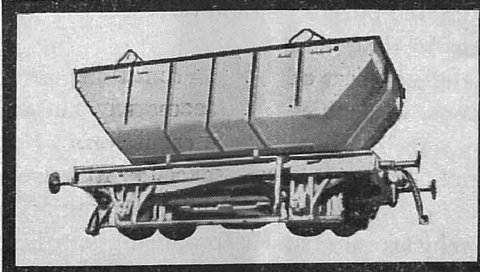

V. J. M. Hopper type Wagon with Drop Bottom Door as used by Queensland Government Railways, Australia.

**PRESSED STEEL COMPANY LIMITED**

*RAILWAY DIVISION, PAISLEY, SCOTLAND* **Manufacturers also of**  
**HEAD OFFICE: COWLEY, OXFORD** **Motor Car Bodies, Prestcold**

*London Office: Sceptre House, 169 Regent Street, W.1* **Refrigeration Equipment**  
**and Pressings of all kinds**

## Forty Years of Sulzer Diesel Traction

**F**ORTY years ago, in September of 1912, the world's first Diesel locomotive ran its trials on the Winterthur-Romanshorn line in Switzerland.

This first Diesel locomotive was equipped with a single-acting reversible four-cylinder Sulzer engine of the two-stroke type which developed a maximum output of 1,600 H.P. at 304 revs. per min. and transmitted its power direct to the driving axles. The nominal rating of the locomotive was approx. 1,000 B. H. P. It had two four-wheel carrying bogies and to driving axles supported in the frame. Its length was 16.6 metres (54 ft. 6 in.) over the buffers and its weight in working order about 95 tons.

In March 1913 the locomotive travelled by way of Basle, Strasburg, Worms and Nordhausen to Berlin, where it was taken over by its purchasers, the Prussian State Railways.

Forty years after this event, it is interesting to look back over the developments which have since taken place and to consider the present situation of Diesel traction.

### HISTORICAL SURVEY

The idea of employing the Diesel engine for rail traction is as old as the engine itself. As early as 1897, when the first practical Diesel engine was completed, its use in rail vehicles was seriously considered, in accordance with the plan which Diesel himself had natured from the outset. More than ten years were to pass, however, before this idea was to take on material form. The creation of Diesel engine suitable for the purpose envisaged was in fact one of the most difficult designing tasks which could have been set before the engineer of those days. Foremost among the numerous difficulties were the problems of weight and space requirements. Whereas in marine propulsion, for instance, fairly wide scope is left for the choice of these two factors, the limits imposed by the requirements of rail vehicles are so narrow that no satisfactory solution to the problem was feasible until the Diesel engine itself had made considerable progress. Other difficulties which confronted the designer were those of starting, manoeuvring and governing, which are for obvious reasons all much more complicated in the traction field than in any other Diesel application.

Sulzer Brothers of Winterthur tackled these problems at a very early stage and made an outstanding contribu-

tion to their solution. In collaboration with Rudolf Diesel and A. Klose of Berlin they founded in 1906 a Society for Thermolocomotives, and enterprise which was to occupy itself with the study and design of large Diesel locomotives. In the following years the engine for the world's first Diesel locomotive was constructed to Sulzer plans in the shops at Winterthur, undergoing its first trials on the test-bed there in April 1912. The planning and building of the mechanical part of the locomotive had been entrusted to Messrs. Borsig of Berlin. The main responsibility for the success of the undertaking, however, lay with Sulzer Brothers, who not only designed and constructed the engine but also installed it in the locomotive with all the necessary auxiliaries and apparatus.

Thus the first Sulzer Diesel locomotive came into existence.

The building of this locomotive was a first practical attempt to use the Diesel engine for propelling a rail vehicle. Although this prototype, with its direct power transmission to the driving wheels, did not give full satisfaction, it at least enabled valuable experience to be acquired and turned to account later in the further development of the Diesel locomotive. The next important advance was the adoption of electric transmission between the Diesel engine and the driving wheels. The output of the Diesel engine is here absorbed by a generator which in turn feeds the traction motors. A few railcars equipped with 200 H.P. Sulzer Diesel engines and with electric power transmission were supplied to German railway companies even before the outbreak of the first World War.

From this point onwards the evolution of the Diesel locomotive and the railcar went forward without intermission. Sulzer Brothers from the first took a special interest in the development of high-powered units, assuming that this would be a particularly promising application of the Diesel locomotive. Their studies in this direction revealed that it was possible to build Diesel locomotives of over 4,000 B. H. P. with weights not much in excess of those of steam locomotives of the same power. The Diesel locomotive was thus able to enter the lists on an equal footing with steam and electric locomotives. Its employment now depended solely on considerations of economy and rail traffic requirements. Diesel traction has special advantages to offer in regions where water is scarce or on lines on which fuel must be carried over long

**Supreme for**

**QUALITY PAPER**



**BANKS**

**LEDGERS**

**CREAMLAI**

**WHITE PRINTING**



**THE SIRPUR PAPER MILLS LIMITED**

**Mills At : SIRPUR - KAGHAZNAGAR, Central Railway.**

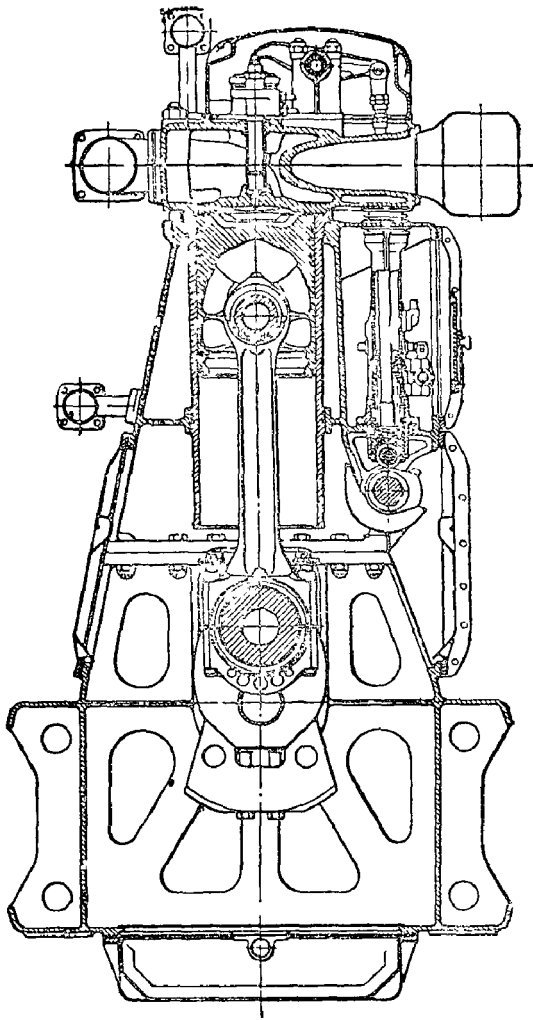

*Cross-section through a modern Sulzer single-row traction Diesel engine of welded design.*

distances. Its low water and fuel consumption and the much easier transport of its oil fuel as compared with coal make the Diesel engine highly suitable for working conditions of this kind. These and allied considerations have in recent years led many railway companies to introduce Diesel traction on some of their lines.

#### CONSTRUCTION OF THE SULZER TRACTION DIESEL ENGINE

The characteristics of the single-row traction Diesel engine as built today by Sulzer Brothers appear from the cross-section, general view and the cross-section of the double-row engine employed for higher out-puts, shown in above illustrations. The crankcase is carried up well above the centre line of the shaft and is therefore very rigid. The U-shaped transverse walls support the crankshaft bearings. The upper halves of these bearings are supported by keys on the projections of the tie bands which form the inner limit of the transverse wall. The tie band transmits the reaction forces of combustion

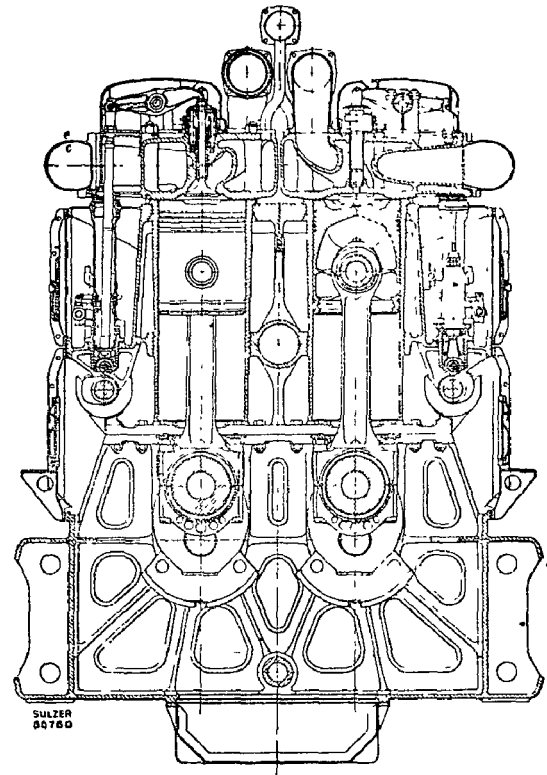

*Cross-section through a double-row Sulzer traction Diesel engine of welded design, 1952 model.*

from the cylinder block along the shortest path to the crankshaft bearing saddles, so that the flux of force takes the simplest possible form. The crankcase also incorporates the members which support the whole engine-generator group on the underframe. On the generator side the bars are extended and curved outwards to take the generator, which is direct coupled to the Diesel engine. The crankcase was originally made of cast iron and later of cast steel, the bars supporting the Diesel-generator group being designed as a sub-frame. Today the sub-frame and the crankcase are welded to form a single whole, which naturally increases the strength of this structure. The transverse walls are of cast steel in the large engines while in the smaller units they are of steel plate like all other parts of the crankcase. This combined design permits the wall thicknesses to be more accurately adapted to the strength calculations than would be possible with an exclusively cast-iron or cast-steel design, and fullest utilisation of the material is thereby attained.

The vibration-free running of the Diesel engine depends partly on the effective balancing of the reciprocating and rotating parts and partly on another important consideration: the question of whether the crankcase is rigid enough to take the stresses due to the internal moments of the masses without any deformation

of practical significance. The design of the Sulzer traction Diesel engine adequately fulfils this latter requirement also, a point in which it is superior to light-metal designs, which tend to plastic deformation and are not entirely satisfactory in their resistance to vibration.

The cylinder block is constructed on the same designing principles, the transverse wall—which are of steel plate in the smaller and cast steel in the larger engines—being welded to the steel-plate longitudinal walls to form a solid block. The water-cooled and interchangeable cylinder liners are inserted in the cylinder block in the usual way.

Each cylinder has its own cylinder cover with one admission and one exhaust valve. The light-metal piston can be readily removed from above after taking off the cylinder cover and unscrewing the connecting-rod bolts.

The fuel pumps are fitted with delivery plungers which are rotated to regulate the quantity of fuel injected and are so arranged that all the supply pipes running to the injection valves in the cylinder covers are of equal length. This permits uniform distribution of the output over the individual cylinders at all loads. The plungers are provided with oblique control edges both for the beginning and for the end of injection. As a definite torque and thus a definite delivery quantity of the fuel pumps is allocated to every engine speed, the preliminary injection can be adapted to the speed in a very simple way.

All moving parts of the Diesel engine are connected to the automatic forced-lubrication system, so that there is no obstacle to an enclosed dust-tight design.

Vibration dampers of the Sarazin type have given excellent service in the control of critical vibrations of the crankshaft. A description of these dampers was given in Sulzer Technical Review No. 1, 1945, page 115.

## CONTROL SYSTEM

The present-day Sulzer control system for Diesel-electric vehicles is no doubt the most consistent embodiment so far achieved of the principle of running the Diesel engine at the most favourable speed for the required traction performance at all times, while setting the load by regulation of the generator excitation in such a way that due account is taken of variations in the loading capacity resulting from the thermal conditions of the engine. The Sulzer control system fulfils these

requirements in the simplest possible way by taking its control impulse from the governor of the Diesel engine. The allocation of a definite torque to each engine speed, a feature introduced by Sulzer Brothers, has made it possible to fix the beginning of delivery by a second oblique control edge on the pump plunger. This is beyond doubt a great simplification. On the other hand, it was only the use of a pressure-charging safety device in conjunction with a spring member fitted between the governor and fuel pumps which enabled the advantages of this output control system to be secured in the pressure-charged Diesel engine. The Sulzer control system thus exercises the following functions :

The field regulator keeps the output of the engine constant on every controller notch within a given range in spite of changes in the resistance to motion (e. g. gradient of line) the temperature of the electric machines or the load on the auxiliary generator.

The load on the engine is reduced, while the engine speed is kept constant, if the pressure-charging safety device comes into action or the output of the engine falls off temporarily for any exceptional reason, as for instance a leakage in one of the fuel pipes.

The pressure-charging safety device takes effect when the charging pressure is too low for the fuel quantity injected, as for instance during acceleration of the Diesel engine or the pressure-charging group, or when the resistance in the suction-air filter is excessive as a result of fouling.

Long years of experience have shown that the Sulzer control system is able to fulfil all the requirements imposed by normal traction service. Supplementary protective equipment has been developed and patented for lines running at great altitudes or with widely varying temperature conditions.

## SERVICE RESULTS

One of the earliest Sulzer Diesel railcars, which first took up service in Germany in 1914, and later, after conversion, came into the possession of a Swiss private railway, is still running today. Throughout this periods no major repairs have been necessary to the Diesel engine, nor have any important component been replaced.

Two travelling power houses of 1,200 H. P. each have been running on the suburban lines of the former Ferrocarril Sud de Buenos Aires since 1930. Each unit is powered by two Diesel engines of a type employing

precombustion chambers and developing 600 H. P. at 700 revs. per min. The vehicles weigh 87 metric tons each and have a maximum speed of 75 km. (47 miles) per hr. In addition to the motors in the power-station vehicle itself, the generators feed traction motors fitted in five of the carriages. This arrangement permits of the high acceleration needed for suburban service. When required, the two power stations can be combined with their carriages to form a 730-ton train seating 1,100 passengers.

These vehicles have covered 60,000 and 65,000 km. (37,500 and 40,500 miles) per year respectively at the low average speed typical of suburban service. About the middle of 1933, the same railway company commissioned three further more powerful travelling power houses, each equipped with two engines of 850 H.P. These units weigh 132 tons and are normally used with eight carriages fitted with two traction motors each. The weight of the train is then 570 tons, the accommodation comprises 800 seats and the maximum speed is 112 km. (70 miles) per hr. The higher output per ton of train weight and the higher maximum speed permit a noticeably better utilisation of these vehicles, each of which has now covered about 2 million k.m. (1,250,000 miles). These mobile power stations are submitted to a general overhaul after each 300,000 km.

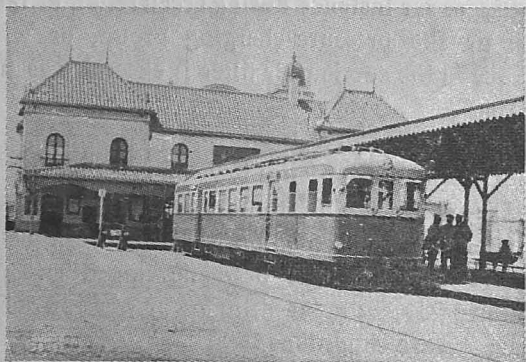

*Diesel-electric railcar, rated at 270 H.P., of the Ferrocarril Provincial de Buenos Aires. Four of these narrow-gauge railcars have covered about 1,600,000 km. or 1,000,000 miles each in 16 years (supplied in 1936).*

Very detailed data are available on the service of four railcars which Sulzer Brothers supplied in 1936 to the Ferrocarril Provincial de Buenos Aires. These railcars, each fitted with a six-cylinder engine having a one-hour rating of 270 H. P. at 1,100 revs. per min., weigh 37 tons and are able to seat 62 passengers. Their maximum speed is 80 km. (50 miles) per hr. In their sixteen years of service up to and including 1951, they had averaged 1,600,000 km. (1 million miles) each.

During the whole service period of these Diesel engines, they have given no trouble of a serious nature. In particular no connecting rods, cylinder covers, liners or fuel pumps have been replaced, although the engines are of a comparatively fast-running type.

Up to the present the railway company has not considered it necessary to undertake capital overhauls.

Locomotives equipped with Sulzer Diesel engines have been adopted on an unusually wide scale in France and the French Colonies. Some of these units were put into service in 1933 by the Compagnie des Chemins de Fer Paris-Lyon-Mediterranee, as it was then designated, and by its Algerian lines, as well as by the Syndicat des Chemins de Fer Ceinture de Paris. Mention should also be made of a series of shunting locomotives, each equipped with a six-cylinder engine developing 735 H. P. at 850 revs. per min. This engine is a standard type of which 117 units have so far been supplied. The locomotives in question were purchased by the Societe Nationale des Chemins de Fer Francais. They weigh 71 tons each and have a maximum speed of 50 km. (31 miles) per hr.

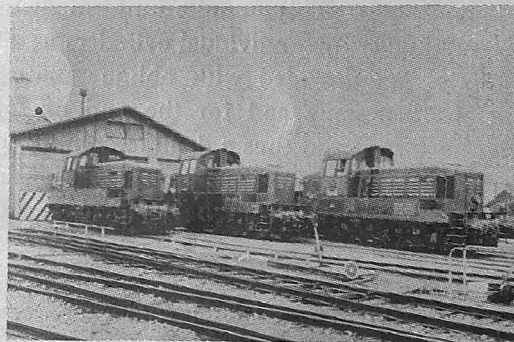

*Sulzer Diesel-electric shunting locomotive of 735 H.P. owned by the Societe Nationale des Chemins de Fer Francais (supplied in 1938). Their experience with these locomotives led the S.N.C.F. to order numbers of other shunting locomotives with Sulzer Diesel engines.*

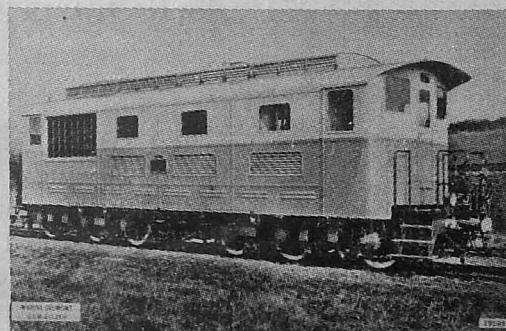

*Diesel-electric freight locomotive of 735 H.P. owned by the Compagnie des Phosphates de Constantine.*



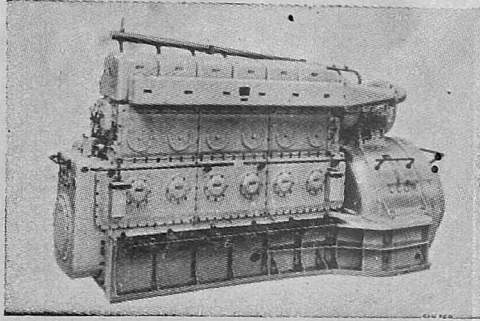

Six-cylinder single-row Sulzer Diesel engine of 735 H.P. at 850 revs. per min., with exhaust-gas turbo-charger. Welded dust-tight design. The frame carrying the main and auxiliary generators forms part of the crankcase.

The same engine type is fitted in the locomotives of the Cie. des Phosphates de Constantine, which have a weight of 67 tons and the same maximum speed of 50 km. per hr. These narrow-gauge locomotives were used for the first three years for pulling heavy train-loads of minerals, on which duty they covered a total of 150,000 and 200,000 km. (94,000 and 125,000 miles) respectively. Since 1941 they have been employed on the lines of the Chemins de Fer Algeriens and the Chemins de Fer Tunisiens. The outstanding results obtained with these locomotives under the most unfavourable climatic conditions, including high air temperatures, sandstorms and the like, greatly contributed to the decision taken by other railways in tropical and sub-tropical countries to purchase Diesel locomotives with the same Sulzer engines. The Cie. des Phosphates et du Chemin de Fer de Gafsa, for instance, has so far ordered 17 of these locomotives, the Chemins de Fer Tunisiens 33, the C. F. Dakar Niger 24, the C. F. Madagascar 14 and the C. F. Cameroun 6.

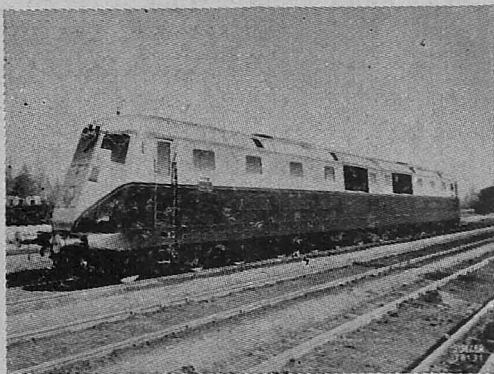

Diesel-electric locomotive rated at 4,400 H.P. and employed by the Societe Nationale des Chemins de Fer Francais for hauling 600-ton trains at 80 km. (50 miles) per hr. on gradients up to 8 per mile (1 in 125), or at 130 km. (81 miles per hr. on the level (supplied in 1938)

The 4,400 H.P. locomotive of the Societe Nationale des Chemins de Fer Francais is of particular interest. It has a length of 33.05 metres (108 ft. 5 in.) over the buffers and a weight in working order of 228 tons, while its maximum speed is 130 km. (81 miles) per hr. This locomotive took up service in the summer of 1938, covered 222,700 km. (139,200 miles) before the outbreak of war and was then taken out of service till the middle of 1945. From this date till the summer of 1952 it again covered 1,300,000 km. (810,000 miles). The maximum wear on the piston ring grooves after a total of 966,478 km. (approx. 600,000 miles) was 1.5 mm.

Owing to the events of the war, very little information has been received on the service results of the 4,400-H.P. express locomotive of the Rumanian State Railways, which is 29.3 m. (96 ft. 4 in.) long, weighs 230 tons in working order and has a maximum speed of 100 km. (62 miles) per hr. The locomotive was employed on a difficult mountain line where it acquitted itself excellently. When put into service, it was the most powerful Diesel locomotive in the world. It attracted a great deal of attention not only in Rumania but in the Balkans as a whole on account of the simplicity of its controls and servicing, its low working costs and its great reliability. It is fairly certain that this successful new design would have resulted in numbers of repeat orders if the war had not intervened. The locomotive escaped the severe bombardments of the Rumanian railways. As it was less dependent on depots than steam locomotives, it was always in very active service, while its stays at the points most exposed to the danger of air attack were kept to a minimum. After the end of the war the locomotive was used for a considerable period as a mobile power station supplying current during the reconstruction of railway workshops.

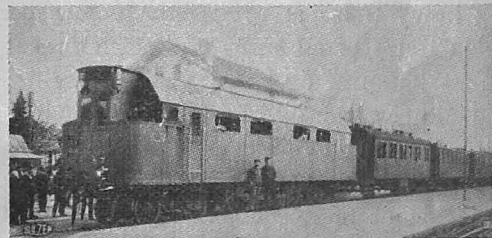

The world's first Diesel locomotive, which was equipped with a Sulzer four-cylinder two-stroke engine of 1,000 H.P. transmitting power direct to the driving wheels.

The 1,200-H. P. locomotives owned by the Swiss Federal Railways, with a service weight of 65 tons and a maximum speed of 110 km. (69 miles) per hr., are each fitted with an eight-cylinder engine running at 750 revs. per min. These locomotives were to be the

prototypes of the vehicles which the Swiss Federal Railways wished to employ on lines with little traffic for hauling light express trains. They were put into service at the outbreak of war, but shortly afterwards had to be taken out of service on account of the shortage of fuel and are now being employed for local traffic on the few lines not yet electrified, where they had covered approx. 600,000 and 700,000 km. (375,000 and 450,000 miles) respectively by the end of 1951.

## NEW UNITS

In conclusion a few examples may be quoted of units which have been put into service in the last few years.

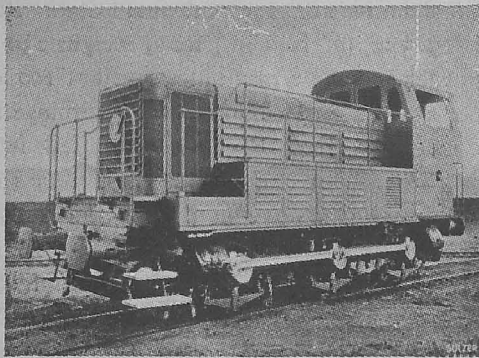

Diesel-electric shunting locomotive of the S. N. C. F., equipped with a six-cylinder Sulzer Diesel engine of 570 H.P.

Prompted by the excellent results obtained with their other Diesel-electric locomotives, the S. N. C. F. decided in 1945 to order 48 Diesel-electric shunting locomotives, each to be equipped with a six-cylinder Sulzer Diesel engine of 570 H.P. The first of these units took up operation in July 1950. They were intended not only for the usual shunting duties on stations but also for handling heavy trains at comparatively low speeds and for hauling trains of all kinds on branch lines at speeds up to a maximum of 60 km. (37 miles) per hr. They are used either alone or in pairs, according to the job in hand. Remarkable results were obtained even during the first trial runs. On the particularly difficult line from St. Etienne to Roanne, which has gradients up to 18 per mille (1 in 55), two unit coupled together were able to handle 600-ton trains without any trouble at an average speed of 50 km. (31 miles) per hr. During the shunting trials in the Lyon-Guillotiere station, trains of 600 and 850 tons were moved from rest by a single locomotive.

The above illustration shows a Sulzer Diesel-electric locomotive of 730 H.P. supplied to Bolivia a few years ago. The Patino Mines and Enterprise Consolidated

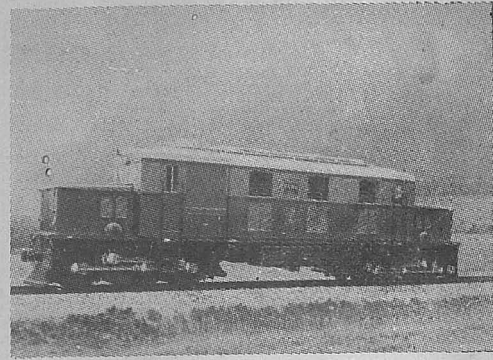

Sulzer Diesel-electric locomotive of 730 H.P. for a Bolivian railway company.

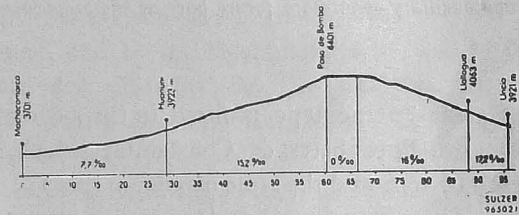

Longitudinal profile of the Machacamarc-Uncia metre-gauge line in Bolivia.

(Incorp.) ordered this locomotive from Sulzer Brothers, Winterthur, with a view to improving the through passenger and goods services on their own winding narrow-gauge line from Machacamarc to Uncia. Sulzer Brothers, who acted as general contractors for the locomotive, built the Diesel engine and its accessories in their own shops while entrusting the Maschinenfabrik Oerlikon of Zurich with the electrical equipment and the Ateliers Metallurgiques S. A. of Nivelles, Belgium, with the mechanical part. A detailed description of this locomotive was given in the Sulzer Technical Review No. 1, 1950, p. 16. The total length of the locomotive is 15.404 m. (50 ft. 8 in.), the maximum service weight 70.4 metric tons. It is driven by a Sulzer six-cylinder Diesel engine with a one-hour rating of 730 H.P. at 750 revs. per min. and 4,000 m. (13,000 ft.) above sea level, and a continuous rating of 650 H.P. at 700 revs. per min. at the same altitude. Extensive trials were run with this locomotive, with trailing weights up to 250 tons, on Swiss narrow-gauge lines.

To supplement their fleet of Sulzer locomotives, the Thai State Railways have ordered from Sulzer Brothers three further Diesel-electric locomotives of 960 H.P. which are intended mainly for service on the 1,200-km. Bangkok-Penang line, the northern section of the run of the "Southern Express" from Bangkok to Singapore. These locomotives will also be used, however, on the mountainous northern line, 750 km. in length, from Bangkok to Chiang Mai. Once more acting as general contractors, Sulzer Brothers ordered the electrical

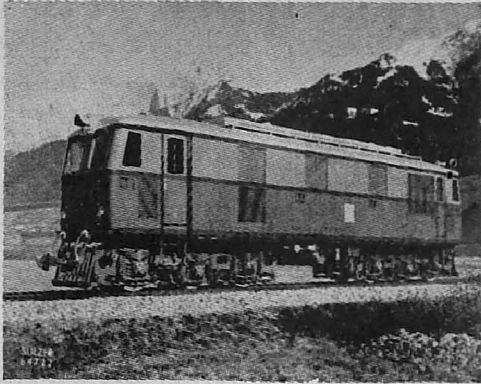

*Sulzer Diesel-electric locomotive of 960 H.P. owned by the Thai State Railways.*

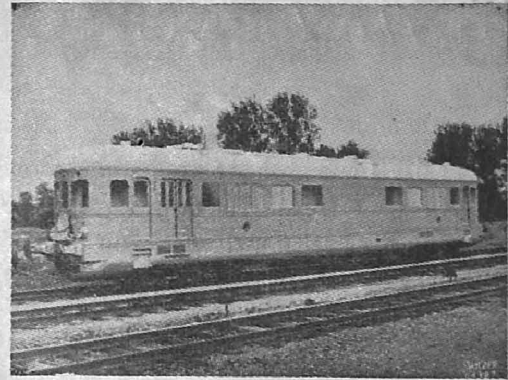

*Diesel-electric luggage railcar of the Chemins de Fer Algeriens, equipped with two six-cylinder Sulzer Diesel engines of 735 H.P. each.*

equipment from the Maschinenfabrik Oerlikon of Zurich and the mechanical part from Messrs. Henschel & Sohn of Kassel. The locomotives are propelled by eight-cylinder Sulzer Diesel engines developing 960 H.P. at 850 revs. per min. A full description of these units was contained in Sulzer Technical Review No. 3, 1951-p. 15.

The above illustration shows a Diesel, electric luggage railcar of 1,470 H.P. for the Chemins de Fer Algeriens. This unit is fitted with two six-cylinder Sulzer Diesel engines of 735 H.P. each.

## CONCLUSION

In the course of four decades the Diesel engine has

earned a reputation as a traction power unit which assures it of an ever-widening field of application.

Engineers from three different branches—the locomotive builder, the Diesel-engine designer and the electrical supplier—all make their contribution to the construction of a Diesel-electric rail vehicle. Each of these branches of engineering has its own traditions, which are founded on many years of experience. The Diesel-electric vehicle can therefore only be a success when the general planning of all three parts is co-ordinated by being placed in the same hands. The successes achieved by Sulzer Brothers in the field of Diesel traction are largely to be attributed to the fact that an organisation created many years ago puts them in a position to act as general contractors for the construction of Diesel-electric vehicles.

---

## CLASS II RAIL COACHES—NO NEW CONSTRUCTION

THE Railway Board has issued instructions that the construction of new second class passenger coaches should cease from now onwards.

This is in pursuance of the policy announced during the last budget debate by the Railway Minister to withdraw second class accommodation from the Indian Railways by stages.

Second class accommodation has already been with-

drawn from 84 branch lines on the seven zonal railways. The coaches thus saved are being utilised partly to increase second class accommodation on other lines and partly to increase third class accommodation on branch lines where second class accommodation has been withdrawn.

For the benefit of through passengers who travel from main lines to the affected branch lines, the railways have made arrangements to issue combined second-cum-first and second-cum-third class tickets.

---

# RAILWAY PLATFORM LUGGAGE TRANSPORT

By A. Jayaram, M. A.

**T**HE other day I was at the City Station to meet my Sister. I was early and the train was late. Finding time hanging on me I sat myself down on one of those Cement Benches and was scanning through that morning's newspaper.

My attention was attracted by a conversation in which two friends sitting beside me were engaged and although I dislike eaves-dropping I lent my ears to it since the subject was of a general nature and of particular interest to me—the topic was 'Transport of Luggage on Railway Platforms'.

The genesis of the topic, I understood was an old Railway Porter carrying a headload—did I say 'a headload'; no it was many a headload—of luggage, comprising all sorts of things, beddings, trunks, baskets,

bundles of different sizes and shapes and what not. Poor old man, he was staggering under the weight of the load and the owners of the luggage—a smart young man and his wife (newly married, I presumed) were walking leisurely behind, stopping and looking at every carriage to find room (rather seclusion) and making the porter halt before every carriage, as they looked in.

One of the friends by my side—let me call him Mr. 'X'—remarked: "This certainly is cruelty at its acme. Poor chap! If the porter does not die under this load, he is lucky. Something should be done to prevent this."

His friend—Mr. 'Y'—said: "You are right, the Railway Authorities should definitely stop this sort of affair. Why should they allow these porters do the work of a Trolley, I wonder."

*For Better Standard of flooring*

**LAY Linoleum FLOORCOVERINGS**



Available in colourful designs, plain pastel shades and many pleasing effects, Linoleum has become the most popular floor-coverings of to-day. Indeed they are so lovely, resilient, hygienic and easy to clean.

**LAY IT FROM WALL TO WALL  
WE LAY IT FOR YOU.**

**INDIA LINOLEUMS LTD.**  
8, ROYAL EXCHANGE PLACE, CALCUTTA-I.

Mr. 'X':— "What do you mean, Trolley? Do you mean to say that the authorities can dispense with the services of all porters and make trolleys do this job, thus depriving thousands and thousands of porters all over India of their only tried means of livelihood?"

Mr. 'Y':— "No friend! I am not suggesting anything of that sort. I am only saying that a Trolley could be used for carrying luggage up and down the platforms and the porters could be engaged to load the luggage on to the trolley and thence to the carriage. This system will not only save the porter—who after all is a human being like any one of us—from being subjected to carrying heavy loads just for a pittance of a few annas and thus slowly but seriously ruin his health, but will also ensure safe and swift carriage of the luggage. It is high time the Railway Authorities looked into this matter and did something to save these human wrecks of porters."

Mr. 'X':— "You are right. But what about the trolleys? Do you know how many the Authorities have got to procure for use throughout all the stations on the various railways? And what do you think each trolley would cost? These are problems that definitely will confront the Railway Authorities, before they do anything of this sort."

Mr. 'Y':— "Now, look here! I wonder how you could be so uninformed as to what is happening under your very nose. Have you ever heard of "An Indian Industrial Institution since 1840" probably the only one of its kind in South India which manufactures a very smart and wonderful type of Platform Trolley at a very reasonable price. I understand too that it has very many exclusive features and are now being used in certain Railway Stations and replacing other forms of manual transport. I am sorry I do not know much about the technical specification or the exclusive features but it certainly is the only answer to the problem viz. "Railway Platform Luggage Transport."

I certainly could not contain myself at this stage of their conversation and barged into it with the customary 'I beg your pardon,' and introducing myself as a representative of the Institution referred to by them.

I said: "I am happy indeed that you are well informed on a subject which is not of great personal

interest to you and am very proud to hear the high opinion you have of our company. I should say with becoming modesty that we are the pioneers in the manufacture of Platform Trolleys in South India and the trolleys manufactured by Indians, for Indians with Indian Capital in one of the most modern workshops of India are the best of their kind. Simpsons Platform Trolleys are manufactured to a very fine standard of perfection and only the best workmanship and finest materials have been employed in this manufacture. We can solve this problem of Railway Platform Luggage Transport."

Mr. 'Y':— (to Mr. 'X') "Did you hear that?" (turning to me) "Well Sir, we have got some time before the train arrives. Will you please tell us how you can solve this problem."

Myself:— "With pleasure. You see, transport of luggage on Railway Platforms by means of porters has many a drawback as you said and to solve this, we manufacture quite a variety of Platform Trucks or Trolleys. Our Standard one is capable of carrying 1000 lbs. load and there are others with smaller carrying capacity of 600 lbs. and 450 lbs."

Mr. 'X':— "That sounds very interesting, carry on friend. Well, answer me this question. What do you think the advantages are of using Trolleys on the Platform?"

Mr. 'Y':— "That is a question."

Myself:— There are decided advantages. You see, the platform trolleys we manufacture are fitted with Solid Rubber Tyred Wheels, and have steerable turn-tables. You can very easily manoeuvre the trolley even on platforms that are heavily crowded, with the least inconvenience to the passengers. Besides it needs little or no effort on the part of the porter handling it. I for one personally feel the powers—that—be put an embargo on human beings being converted into beasts of burden and insist on the use of trolleys for transporting luggage on platforms. It will be more efficient, quick, decent and dignified to carry loads on trolleys than on human heads.

Mr. 'X':— "Excellent, Sir, I am very glad to learn that Simpson & Co. Ltd., are certainly trying to do a veritable service to the country and to the class of human beings, whom we so callously call 'coolies.'"

Myself:—"Certainly, if we are given sufficient impetus we can manufacture any type of trolley to suit individual requirements. As it is, we also manufacture, besides Platform Trolleys, Sack Trucks in two varieties—Heavy Duty and light type capable of carrying goods. Put together the Platform Trolleys and Sack Trucks can be profitably and advantageously used to carry 'anything and everything'—to use a hackneyed phrase. The operation of these trolleys does not involve any strain on the operator. And I may say positively that these wheeled vehicles will go a long way in successfully solving this problem—'Railway Platform Luggage Transport.'"

Mr. 'Y':—"Thank you very much, Sir, for such a pithy and erudite appraisal of Simpson's Service to the Nation. It is a pity we can't have a complete

picture of the multifarious activities your company is engaged in as the train is almost on the Platform. However, we hope we will have another opportunity to have the complete story. Nevertheless we are greatly indebted to you for the information you have given us. You see, educating public opinion is the first and right step towards solving any problem and we shall do our best to broadcast this intelligence in our own way".

The train was on the platform and I bade good-bye to my friends (?) and was looking for my sister when I heard a loud noise. I turned round and found that a porter had dropped a heavy luggage unable to bear its weight. The owners of the luggage were abusing and cursing him. And I said to myself "This can't and won't happen if a Simpson's Platform Trolley had been used."

---

## ELECTRICAL ADVISER FOR RAILWAYS

Mr. P. N. Murthi, formerly Chief Electrical Engineer of the Northern Railway, has been appointed to the newly created post of Electrical Adviser with the status of Director in the Railway Board's office.

The post has been created, it is stated, in view of the increasing work in connection with the electrification of the railways.

The Electrical Adviser, among other things, will deal with various aspects of railway electrification—purchase of electric power for the railways and work connected with the generation, transmission and utilisation of electricity—electrification of stations, air-conditioning of buildings and rolling stock, train lighting and liaison with other Ministries on matters connected with this work, including the supply, utilisation and manufacture of electric equipment and plant.

---

## ANNOUNCEMENT

We have pleasure in announcing to all Advertisers and Subscribers that we are issuing a special Supplement for Christmas along with our December 1956 issue.

**Editor**

# Coal Freight Accounts By Punched Cards

By *A. A. Foren*

*Head of the Mineral Accounts Section of the Chief Accountant's Office,  
British Railways (Western Region), Barry Docks.*

**T**HE application of punched card methods to the work of compiling Railway Coal Freight Accounts is well out of its infancy; in fact the Mineral Accounts Office responsible for safe-guarding and collecting the revenue arising from the conveyance of coal and coke originating on the Western Region of the British Railways, has been using and developing the system for more than twenty years. It will be appreciated, therefore, that the idea has long passed from the experimental stages to that of established practice.

A short outline of the procedure adopted to meet the rather unusual features of the work in connection with Railway Coal Freight Accounts may interest other users and potential users and, in some way, assist in solving some of the problems connected with the fitting of mechanical accounting to circumstances which, at first, seem unpromising.

## DECLARATION BY CONSIGNOR

The charging of "Coal Class" traffic is primarily based on a declaration, variously known as a Consignment Note or Colliery Permit. This is required to be handed to the local Railway Agent when traffic is tendered for conveyance and includes, *inter alia*, all the information required to enable the charges to be assessed, *viz.*—

- (a) The point from which the traffic is to be taken.
- (b) The point at which the traffic is to be delivered.
- (c) Net weight contained in each wagon, totalled if more than one wagon.
- (d) Date.
- (e) Name of party liable for conveyance charges.

## INVOICING

From the information shown on the Consignment Notes, the forwarding station Agent prepares a document known as a "Weight Invoice"; this is sent to the Agent at the station to which the traffic is consigned and the arrival of the wagons is thereby checked.

The forwarding station Agent summarises daily the details shown on the "Weight Invoices" issued, and sends this summary, together with the relative consignment notes, to the Mineral Accounts Office.

## CHARGING AND PREPARATION OF ACCOUNTS—MINERAL ACCOUNTS OFFICE

### (a) *Daily Record of Tonnages*

The total tonnage of each summary received from the forwarding station is recorded daily and a Regional total obtained.

### (b) *Pre-punched Cards—White*

Much of the information required for the preparation of accounts recurs day by day and a file of white cards is maintained pre-punched for the forwarding point, the receiving point, the rate per ton, and, in some cases, a code number signifying the account to be debited. Experience has shown that these cards cover approximately 70 per cent of all consignments.

### (c) *Unpunched Cards—Green*

A supply of unpunched cards is available for the 30 per cent residue; these cards are green.

### (d) *Preliminary Operations for Completion of Cards*

The station summaries and consignment notes, referred to under "Invoicing" above, are passed each day to female operators who refer to the file of "white" cards and extract cards for each consignment for which an appropriate pre-punched card is available; a "green" unpunched card is interpolated for the residue not covered by the pre-punched file.

The items covered by the green cards are then subjected to further examination and the cards are punched with the destination details.

The code number of the freighter (*i. e.* party paying carriage) is in some cases already provided for on the white cards; for the remainder, the information is, at this stage inserted on the respective consignment notes.

The consignment notes and cards, each assembled in the same order, are then passed to punch operators who punch—

(a) Code number of account to be debited (if not already pre-punched)

(b) Date

(c) Weight  
and additionally in the green cards only—

(d) Forwarding station (in code) and the Colliery.

The cards are then tabulated in the same order with the tabulators set to provide—

(a) Sub-totals, representing forwardings of each station

(b) Grand total of the day's forwardings.

These tabulations are scrutinised by clerks, who compare them with the consignment notes and satisfy themselves that the tabulated information is correct in all details, or amend as necessary; in this process the sub-totals are compared with those shown on the Agent's daily summary which accompanied the consignment notes.

The corrections indicated by the checkers are then carried out on the cards and a further check imposed to ensure accuracy.

#### (e) *Balance Control Book Totals*

A reliable grand total of the tonnage forwardings for the day is now available and is recorded in a "Balance Control Book" designed to ensure the maintenance of tonnage and charges balances through all the stages of the work; the inclusion of charges in the book is covered by succeeding operations as detailed below.

It is claimed that the control exercised by the medium of the "Balance Control Book" is so effective that once a consignment has come under notice it cannot by inadvertence be overlooked through the loss of the consignment not or the Powers-Samas card on which it is recorded.

#### (f) *Separation of White and Green Cards for Further Operations*

The reader will gather from the foregoing that the cards at this stage contain all the information required except—

(a) White cards require evaluation

(b) Green cards require rating and evaluation.

The cards are therefore passed through the automatic sorter to separate them into these two categories.



*The well laid-out battery of Automatic Key Punches at the Mineral Accounts Section, Barry Docks.*



*(g) Evaluation of White Cards*

The cards are machine sorted into gradations of rate and weight and ready reckoners specially compiled with separate pages for each rise of rd. rate, showing, for each rd. rate, the evaluation at each 1 cwt. stage, are available for assessing the charges; with ready reckoner and cards in sympathetic order, the work of writing the cash values on the cards is carried out with surprising speed.

These written amounts are then punched into the cards, which are again tabulated, this time setting the tabulator to produce sub-totals of tonnage and cash at each variation of rate.

A check is made to determine that the sub-totals thus produced are correct in calculation, and if so, it is assumed the individual cards comprised are correct.

After carrying out the correction of those cards found to be inaccurate and suitably amending the grand total, the grand totals of tonnage and cash are recorded in the "Balance Control Book," and the cards are set aside until required at the month's end for freighters' accounts.

*(h) Rating and Evaluation of Green Cards*

The cards are tabulated and clerks, working from rate books, of which there are several hundred, insert the chargeable rates on the tabulation and return it to punchers to carry the information to the cards.

Accumulating several days, as convenient, the cards are sorted in an order which corresponds with the rate books and tabulated again for rate checking, after which they follow the same procedure as the white cards.

*(i) Production of Monthly Accounts*

At the month end all the cards are assembled and sorting is commenced for the production of the monthly accounts.

The accounts vary widely in size, from a single item to thousands, but all are sorted into alphabetical order to assist the freighters to check the accounts and to enable them, and the Mineral Accounts Office staff, to quickly locate any particular consignment.

The sorting is broken down to comparatively small batches of groups of freighters for convenience of handling and also to allow the tabulation of some of the accounts to go forward whilst the remainder are still in the sorting stages.

As the accounts are tabulated they are passed to a punch operator who punches Ledger Posting card to record—

(a) Freighter (Code number)

(b) Grand Total, tonnage and cash,

and the grand total, tonnage and cash, of these cards, when ultimately tabulated, should agree in total with the figures already ascertained and entered in the "Balance Control Book."

The accounts then pass to clerks for finalising by the addition, by hand, of supplementary debits which arise in respect of earlier months' accounts from diversions of consignments, amendments of declarations, and other causes. Cards are punched to represent these debits, and together with the Ledger Posting cards referred to in the previous paragraph, are used to produce the Ledger Posting Sheets, from which, as the name implies, the debits are posted to the Ledger Accounts.

*(j) Check with Receiving Station Returns*

After the freighters' accounts have been completed and balance achieved, the whole of the cards are resorted by machine into receiving station order and a separate tabulation producing for each Railway Region for the purpose of checking with the receiving station's returns of invoices received, so completing the chain of checks necessary to ensure that the correct charges are collected on all traffic that passes.

## INSTALLATION

The installation consists of 3 Powers Samas Tabulators, 8 Automatic Key Punches, 3 Sorters, 1 Reproduces, and deals with 65/70,000 consignments per month.

# HISTORY OF FIAT.

*By Our Correspondent*

**FIAT**, whose name is known throughout the world chiefly for their motor cars, which are to be met with on the roads of every continent, including India, are also active, through their Railway Rolling Stock Division, in the field of railway transport. As long ago as 1931 Fiat were the first Italian Firm in the mechanical engineering field to realise the importance of applying the technique of the road motor vehicle to railway traction. In that year the first Fiat railcars were produced. These were driven by petrol engines, but a change was soon made to diesel traction which is cheaper to operate and presents less risk of fire. Fiat railcars have since attained wide use in many different countries. Fiat have built and supplied over 800 railcars and motor trains to the Italian and to foreign railways.

Still further back, in 1923, Fiat started to build diesel locomotives, several of which were supplied to the then Italian Colonies.

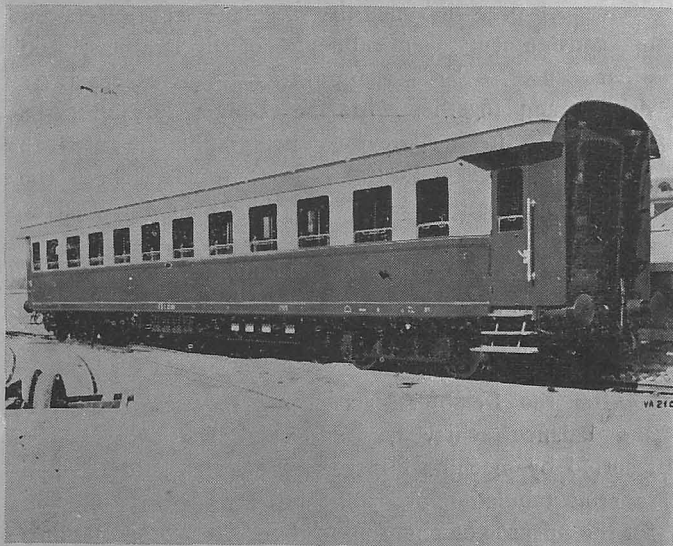

*3-class passenger coach built by Fiat for the Italian State Railways.*

The Fiat Company, of which the Railway Rolling Stock Division is a part, was founded in 1899 (with about fifty workmen and with premises covering an area of 107,640 sq. feet) as a motor car factory: **Fabbrica Italiana Automobili Torino**, from the initials of which was formed the present name of FIAT. But in the course of more than half a century of continuous development Fiat has become not only the largest motor car factory in Italy, but one of the biggest industrial groups in Europe in the manufacture of motorised products for land, sea and aerial transport; hence the

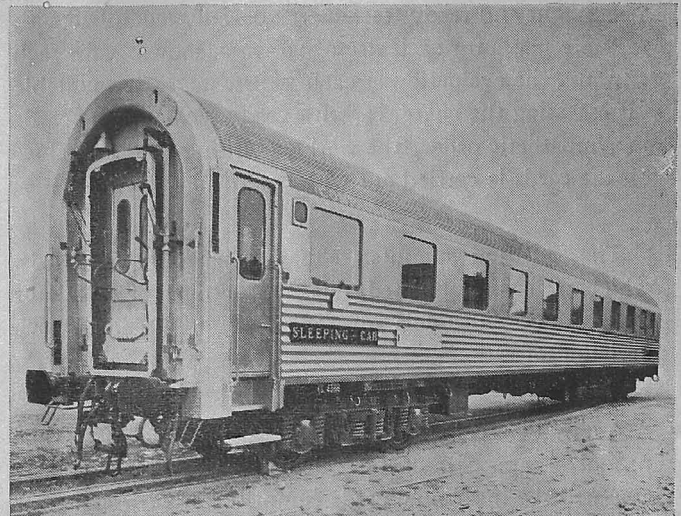

*Stainless steel sleeping car built by Fiat to the order of the "International Sleeping Car Company" (Budd licence).*

slogan "FIAT Land, Sea, Air". Besides railway rolling stock, Fiat makes motor cars, buses, lorries, vans, trolleybuses, diesel marine and land engines, aircraft and aviation engines (including jet planes and turbojet engines), machine tools, electric household refrigerators and clothes washing machines, lubricating oils and greases.

Fiat productions begin with iron and steel processing (stainless steels are also made by Fiat under licence from the Republic Steel Corporation of America), general metal working and, up through all the various manufacturing and transformation processes to the terminal mechanical products.

Fiat has at present 20 Factories and employs over 75,000 people; it has a sales and technical assistance service organisation which encircles the globe.

The rolling stock production of recent years includes several diesel 3-car trains supplied to the order of the Spanish and Portuguese Railways; a large number of railcars for the Italian State Railways as well as for the Greek Railways; saloon rail cars for Jugoslavia and Egypt and 12 motor train sets for India. Lately Fiat has been granted a manufacturing licence by the Budd Corporation of America for stainless steel railway coaches. One of these — a double-deck sleeping car with 20 single berths, supplied to the International Sleeping Car Company — is illustrated here. The other photograph shows the first of a series of 3 class passenger coaches for the Italian State lines. Diesel locomotives for shunting and main line service are now also being built to the order of the Italian State Railways.

# Hundred years of Rolling Stock Production in Sweden

*By A Correspondent*

**M**ORE than a century has elapsed since 1847, when our firm was founded under the name of Trollhätte Mekaniska Verkstad (The Trollhattan Engineering Works). In 1850 the name was altered to Nydqvist & Holm, and in 1916 the firm was converted into a limited company, under the name of Nydqvist & Holm Aktiebolag (NOHAB).

To start with the manufacture comprised water turbines, steam engines, and various machine parts. After a few years the manufacture of locomobiles was taken up, and the step was then not far to locomotives, which, as a matter of fact, from the very beginning had been contemplated as a future speciality. The first locomotives were ordered by one of the private railways in Sweden, and the delivery began in 1865. One of these locomotives is now in the Railway Museum, Stockholm,

and another of them was in service for 70 years before being scrapped. Many locomotives of our make are after more than 75 years still in daily service. The first three locomotives built for the Swedish State Railways were delivered in 1868.

We have always been anxious to make use of all improvements in the locomotive sphere, and in this connection may be mentioned that compound gears and superheaters were applied at a comparatively early stage, and further, amongst the first 3-cylinder locomotives in Europe were those supplied by us in 1913. In 1925 we commenced to build steam turbine locomotives under licence from Aktiebolaget Ljungstroms Angturbin, Stockholm, and amongst engines of this type may be mentioned the non-condensing turbine locomotives for iron ore transport, supplied by us to the Trafikaktie-

## *Editorial Notice*

The Editor invites contributions to the Magazine on a variety of topics—short stories, technical features written in simple English understandable to the laymen, aspects of Railway working, places of tourist interest, news from home line, activities on Railway Institutes etc. All copy should be brief and typed as far as possible.

Photographs illustrating social functions, sports events, scenic sports etc. are also invited. All contributions should reach the Editor not later than 5th of each month. Rejected Mss. will be returned provided sufficient stamps for postage are enclosed. No responsibility will be borne for copy lost in transit.

*Views expressed in this Magazine should not be taken as having official authority.*

All correspondence should be addressed to the Editor, "Southern Railways Magazine," Post Box No. 17, Tanjore. (South India)

bolaget Grangesberg-Oxelosunds Jarnvagar (The Grangesberg-Oxelosund Traffic Co's Railway).

Sweden's richness in water power soon led to the electrification of the Swedish State Railways. Electric locomotives had been built by us before 1900, but it was first in connection with electrification of the state railways that the manufacture of such locomotives became of real significance. The first of these locomotives was of the type I-C-1, a coupling rod type of locomotive, of which we have since delivered a great number. During recent years several private railways have been electrified, and locomotives of various types for these railways have been built by us.

Completion from omnibuses and lorries has, in instances where electrification has not been considered suitable, compelled the railways to motorize the service, and this induced us to take up the manufacture of motor driven locomotives and rail cars. The first rail car built was of the 4-wheel type but nowadays our rail cars are normally of the 8-wheel type with two bogies.

Our manufacturing programme comprises not only locomotives and rail cars but also other kinds of rolling stock, such as special wagons of various types, rotary snow ploughs and impregnating plants.

To meet the ever increasing demands considerable extensions of our workshops have been carried out time and again. Our works originally covered an area of 8,300 square metres, and they now extend over more than 205,000 square metres. Our shops with a floorspace of 59,000 square metres are full equipped and up-to-date in every respect.

The placing of our works at Trollhattan was to a large extent dependent on access to water power and to a waterway to Gothenburg, Sweden's largest port. In 1922 a special quay was built and equipped with a crane allowing assembled locomotives to be lifted on board ships, specially built for the transport of locomotives. We have our own railway, with a length of 3 kilometres, connected to the Swedish State Railways and thereby also to the Continent. Trial runs of locomotives are

made on our railway. We have also connection to the narrow gauge railway system of Western Sweden.

Our deliveries of locomotives have made the firm known far beyond the borders of Sweden. Scandinavia and Finland have early been our customers. Amongst other countries, to which we have supplied rolling stock of various kinds, may be mentioned The Argentine, Brazil, Iran, Netherlands, Poland, Portugal, Roumania, Turkey, U. S. S. R., and the Union of South Africa. Our deliveries have been large, especially to Iran, Turkey and U. S. S. R. In 1920, the Soviet Government ordered 1,000 heavy goods locomotives, one of the largest contracts in the history of the locomotive industry, which made further large extensions to our works necessary. In order to utilize the increased capacity of our works it was necessary to look for new markets.

Early in 1927 the Turkish Government favoured us with a rather unique and complicated commission. The contract entered into comprised the building of railways with a total length of 900 kilometres, and the delivery of 100 locomotives and 1,500 coaches and wagons of different types. The railways were built in collaboration with the Danish firms Kampmann, Kierulff & Saxild A/S and J. Saabye & O. Lerche. The rolling stock was supplied by us. The whole contract was completed in nine years. The enterprise was followed by a similar commission given by the Iranian Government to the three collaborating firms, who under the name of "Consortium Kampsax" undertook the building of the Transiranian Railway. We supplied the rolling stock, consisting of locomotives, goods wagons, coaches, diesel-electric rail cars, some special wagons and a saloon-car for H.I.M. the Shah.

Since April 1950 there exists an agreement between us and the General Motors Corporation, Electro Motive Division, La Grange, with a view to build and market diesel-electric locomotives utilising General Motors Corporation's constructions and equipment sets consisting of diesel engine, main generator and other supplementary equipment.

The Swedish locomotive builders formed in 1945, a sales company, Swedish Locomotive Works Association Aktiebolag for the export of steam locomotives. Nydqvist & Holm Aktiebolag is a member of that association.

# Archdale Radial Drilling Machine

## for use in Railway Workshops

**T**HE complete range of Archdale Radial Drilling Machines are used in considerable numbers in the Railway Workshops, but for the purpose of this article it has been decided to devote the attention to the Heavy Duty Radial Drilling machines with hydraulic pre-selection of speeds and feeds. These machines are built in eight sizes with a 5 ft., 7 ft., 8 ft., 9 ft., 10 ft., 11 ft. and 12 ft. radius.

Designed for heavy duty high speed drilling up to  $3\frac{1}{2}$ " in mild steel, the machine has a wide range of speeds and feeds, for drilling, boring, reaming, facing and tapping operations. Both the speeds and feeds can be pre-selected whilst the machine is actually drilling which reduces to the minimum idle time between operations. The controls are conveniently placed low down on the saddle to relieve the operator of all arduous work when the arm is in the high position on the saddle.

The Machine is foolproof and cannot be damaged by incorrect use. Safety trips are provided to prevent over-traversing of the arm and the spindle. Moreover a special safety clutch stops the movement of the arm in either direction should any obstruction be encountered.

The speed and feed gears cannot be damaged by careless changing, as these changes are automatically effected. Clutches are provided to prevent overloading of the speed and feed drives. Should the motor which controls the locking mechanism be left running after the machine is fully locked, an electro-hydraulic locking device safeguards the locking mechanism against overload.

The machine is of the pillar-sleeve type, the sleeve being mounted on the pillar on ball and roller bearings. The sleeve is locked on the pillar by a conical ring, which moves in a vertical direction and thus prevents any displacement of the tool in the horizontal plane during locking.

The mechanism for locking the arm to the sleeve incorporates a long split bearing to obtain a secure lock. The locking or unlocking of the sleeve to the pillar and of the saddle on the arm is effected simultaneously by push-buttons in the centre of the transverse handwheel, controlling on electro-hydraulic motor.

The elevating arm is provided with a wide bearing face for supporting the saddle. A tensioned hardened steel strip on top of the guides on which the saddle traverses, minimises wear and maintains the original accuracy of traverse indefinitely. The arm is automatically locked to the sleeve upon release of the elevating switch lever on the saddle. This locking is independent of the simultaneous locking of the sleeve on the pillar and the saddle on the arm, and consequently the arm swings in the radial direction whilst it is locked to the sleeve. Vertical displacement of the tool during setting in the horizontal plane is eliminated and drilling with the arm unlocked is impossible.

When the elevating switch lever on the saddle is released the direction of rotation of the elevating screw is automatically reversed and the locking effected by a separate nut. The movement is automatically stopped when a full lock has been effected. Alternatively, when commencing to elevate the arm the special nut moves first, and unlocks the arm before the elevating nut comes into action. Should the elevating nut fail the arm will not drop as the special locking nut comes into operation and automatically locks the arm, which cannot then be lowered or raised until the elevating nut has been replaced by a new one.

The elevating nut is provided with an aperture to enable the wear of the thread to be checked.

The combined locking of the sleeve on the pillar and the saddle on the arm is effected by an electro-hydraulic device, which is fitted at the head of the column. The device is rapid in action, simple and free from trouble, and provides protection against overload.

Piping and consequently oil leaks are eliminated, as the oil pump piston motor and safety valves are carried in a totally enclosed housing. The locking or unlocking operates immediately the motor is started by the push-button control, the slightest pressure on the control button being sufficient to provide any degree of lock. Arrows on the base of the sleeve indicate the actual degree of lock and this is adjusted so that the sleeve can be locked on the pillar before the saddle on the arm, thereby permitting a slight movement of the saddle along the arm, whilst the radial movement is locked.

The required speeds and feeds are selected by turning two concentric direct reading dials on the saddle. The actual gear changes are not effective until the start and reverse lever is operated. This lever engages three actions in sequence :—

- (1) The hydraulically operated gear change
- (2) The delayed starting of rotation of the gears
- (3) Engagement of the full drive

With this arrangement the pre-selected speed and feed is obtained whilst the motor is running, with ease and without clashing the gears.

By dialing 'O' the drilling spindle is set in neutral, and is free to be turned by hand for changing tools.

A multi-disc clutch is provided for smooth engagement and disengagement of the gears, to provide for sensitive control of the spindle, especially for tapping and rapid reverse. This clutch requires, no adjustment and is designed to pull smoothly and maintain its driving power under the severest test. A constant even pressure is compensated and distributed over the entire surface of the plates. When the clutch is disengaged the plates are separated by oil pressure and separately held on "Steps" so that opposite contact is eliminated.

Wide speed and feed ranges are provided, so that drilling, boring reaming, facing studding and tapping operations can be done. Fine boring as well as heavy drilling can be carried out and four automatic tapping feeds are available if required. The five feeds are available for boring work held in jigs and fixtures which is normally carried out on horizontal boring machines, a high degree of accuracy and surface finish being obtained. Particular care has been given to provide the low speeds frequently needed for boring. The twenty-two speeds and eighteen feeds available are as follows.

*Speeds:* 11, 14, 17, 22, 28, 35, 44, 55, 70, 90, 110, 140, 175, 220, 270, 350, 440, 560, 680, 880, 1100 and 1450 r. p. m.

*Feeds:* 8, 11, 14, 18, 25, 30, 36, 48, 62, 75, 100, 125, 160, 215, 270, 320, 425, 540 r. p. m. The Automatic tapping feeds are 8, 11, 14 and 18 r.p.m.

A precision depth trip is provided to ensure accurate drilling or facing of blind holes to the correct depth. The power feed is tripped by means of an integral dead stop which ensures ~~uniform~~ accuracy of depth of

hole without the necessity of other measuring devices. The required depth is set on a clearly graduated feed trip dial, which is provided with a micrometer screw the latter being adjusted after rapid setting of the dial.

The fine feed hand wheel is stationary when the power feed is in use. A lever adjacent to the fine feed handwheel engages either the hand or power feed.

Ease and rapidity of control are outstanding for a machine of this size. The controls are simple and few in number and are located close together on the lower face of the saddle. As the speeds and feeds are pre-selected whilst drilling is in progress, gear changing time is eliminated, and as spindle setting, reverse and gear change are effected without stopping the motor, no second control movement is necessary.

An Automatic brake quickly stop the spindle and prevents "Creeping". The free and easy action of all movable parts combined with the small area into which the controls are grouped, enables the operator to manipulate all movements of the machine from one convenient position which results in a remarkably high output rate without fatigue. All locks are obtained by finger-light pressure, and their ample rigidity is such as to ensure long tool life and also to safeguard against tool breakage. A tachometer is fitted which indicates the speed in use, and a circular scale enables the operator to find the appropriate speed and feed for different materials by direct reading.

In addition to a normal base plate the machine can be supplied with special bases to suit individual requirements. These include :—

- (a) Small "Stub" base for operations where boilers or other bulky components have to be drilled, which can be accommodated in a pit adjacent to the base.
- (b) Traverse base where it is necessary to drill large surfaces, the traverse of the machine on the slide is controlled from the saddle.
- (c) Two-three or four-way bases to provide for continuous production whilst work is being drilled on the one base, other work may be set up or removed from the others.

The agents in India for James Archdale & Co. Ltd. are, Alfred Herbert (India) Ltd., Calcutta with branches at Bombay, Madras, Bangalore and Secunderabad.

# HOW TO RESERVE ACCOMMODATION

Unless you reserve your berth (I and II Class) or Seat (3rd Class long distance) in advance, you may not be sure of getting accommodation on the train you wish to travel by.

Application should be made to the Station Master of your starting station at least 3 days in advance specifying the date and train by which you intend travelling and the tickets must be bought in advance. The reservation fee leviable is 8 Annas per seat or berth.

Reservation by I and II Class from intermediate stations by Express trains can also be made similarly, but reservation ticket can be issued only after getting an advice from the Reservation Centre that the reservation has been made.

Tickets will be issued only if accommodation is available.

If the reserved seats or berths are not occupied at least 5 minutes before the booked departure of the train the reservation will be cancelled and the seat or berth given away to another.

*Reservation fee is not refundable.*

III Class seats are also reservable on Express and certain other important trains for long distance passengers from the train-starting stations on payment of a reservation fee of 4 Annas per seat.

Do not occupy a berth or seat reserved for another, as you are liable to be displaced at the last moment.

If you find another person occupying the berth or seat reserved for you and if he will not vacate it on demand, report it to the Guard or Station Master. They will help you.

*( Inserted in the interests of Travelling Public )*

# CLEANLINESS LEADS TO HEALTH AND HAPPINESS

*Clean orderly habits contribute to general health and welfare and as such to happiness and prosperity; they are more important than medicines.*

*Cleanliness prevents disease; medicine only attempts to cure.*

*Cleanliness of the person, of the houses and colonies, reflects discipline in the individual and the community. Discipline is the foundation stone for progress of oneself and the country. Cleanliness is a good habit. It is also cheap.*

*All Railwaymen should set an example of cleanliness. This will help others and themselves.*