

# MAN IN INDIA

---

VOL. 49 } OCTOBER-DEC. 1969 { NO. 4

---

## BIJAY CHANDRA MEMORIAL LECTURES 1967

S. S. SARKAR

*(Received on 21 February 1968)*

### *Preface*

THE accompanying two lectures were delivered at the Department of Anthropology, University of Calcutta, on the 12th and 13th February, 1968. I take the opportunity of expressing my grateful thanks to the Vice-Chancellor and the Syndicate of the University of Calcutta for appointing me Bijay Chandra Memorial Lecturer for 1967.

### I

#### **Acharya Bijay Chandra Mazumdar**

Acharya Bijay Chandra Mazumdar was a legacy of the 19th century, which gave Bengal many of her illustrious sons. Bijay Chandra had the talents of a poet, a historian, an anthropologist, a philologist and a lawyer. He was born on 27 September 1861 at the village of Khatkula in the district of Faridpur in a Varendra Brahman family. His father Harchandra Mazumdar was a zemindar of repute. Bijay Chandra started his education at the Krishnagar Collegiate School. Here he had the opportunity of having the famous playwright and poet Dwijendralal Roy as his class-mate. This

association ripened into life-long friendship. A reference of it may be seen in Bijay Chandra's famous essay *Madhyanha Sangeet* which is an example of classic literature, and at one time found its place among the selected readings for the Intermediate students of the Calcutta University (1924-26).

Bijay Chandra graduated from the Calcutta General Assembly Institution in 1883. Soon he joined the Sambalpur Government School as its headmaster, prior to which he had been the guardian tutor to the princes of the then States of Bamra and Sonapur. In 1888 Bijay Chandra married Basanti Devi, the eldest daughter of Bhaktakabi Madhusudan Rao, the eminent educationist and social reformer of Orissa. In 1895 Bijay Chandra obtained his B. L. degree and started the practice of law at Sambalpur. He also acted as a legal adviser to the States of Bamra and Sonapur, and took an active part in the welfare and administration of the two States. He had settled down at Sambalpur. His doors were open to all, rich and poor, stranger and friend. In 1908 he went to London to attend the conference of World Religions and his thoughts on the philosophy of life have been embodied in his *Jivan Vani*. His eyesight began to fail and hampered his scholarly pursuits. It was at first thought to be a cataract but later on it was diagnosed as glaucoma. He became totally blind in 1914 after a surgical operation.

It is tragedy to lose one's eyesight, but Bijay Chandra did not lose heart. In fact most of his works were published after 1914.

Bijay Chandra then settled down in Calcutta, and devoted himself to writing the history of the Bengali language, which was published in 1920 by the University of Calcutta. Soon he came to the notice of Sir Asutosh Mookerjee, who appointed him as a Lecturer in the newly created departments of Anthropology and Modern Vernaculars. He had already come in contact with the aborigines of Central India, particularly the Kols. His knowledge of philology was of great help in anthropology. He was one of the earliest authorities to point out the presence of Dravidian words in the Sanskrit language. I remember with profound respect the day when

he explained the Maler vocabulary collected from the field by me. He had a deep knowledge of Sanskrit, Pali and Oriya and made veritable contributions in these fields of research.

In his postgraduate classes he used to teach Westermarck, whose works are not nowadays so much read. I still remember how vividly he lectured upon Westermarck's Theory of Aversion. He had his faith in it, so to say.

Bijay Chandra's association with Keshab Chandra Sen and Pandit Sivanath Sastri drew him into the religious sphere. He was deeply nationalistic and his poem *Bharat Pataka* was a national song of the day.

Bijay Chandra died on the 30 December 1942 full of honours. His legacy is now being upheld by his equally gifted only daughter, Mrs. Suniti Sarkar, to whom the present endowment-lecture in Anthropology is due. All anthropologists will acclaim it as a worthy commemoration of a worthy father.

In spite of his losing eyesight, the indomitable spirit of Acharya Bijay Chandra Mazumdar guided him the last 28 years of his life and it was no less a glorified one. Let his spirit be a source of inspiration and emulation to all the future workers in the field of Anthropology.

I am deeply indebted to Mrs. Tapati Mukherjee, granddaughter of Acharya Bijay Chandra Mazumdar for her kind help in presenting this short biography. Thanks are also due to Miss Ratna Mallick for the following bibliography prepared from the library of Acharya Mazumdar, access to which was very cordially extended to us by Professor Bijali Behari Sarkar and his wife, Sunity Devi, who is responsible for the present endowment.

#### BIBLIOGRAPHY

##### *Literature*

Kheladhula	Kedar Nath Chatterjee
	120/2, Upper Circular Road, Calcutta
Jiban Vani	Narendra N. Kongar
1934	203/1/1, Cornwallis Street, Calcutta
Heal	Priya Nath Bhattacharja
1916	25, Sukia Street, Calcutta

- Ruchira  
1938  
Author, 33/3, Lansdowne Road, Calcutta
- Udanam  
Sadhana Library, Dacca
- Chinte-phota  
Pramatha N. Sen, 15, College Square, Calcutta
- Prachin Sabhyata  
Chittaranjan Gupta, 24, Middle Road, Calcutta
- Katha-nibandha  
1906  
Mazumdar Library, 20, Cornwallis Street,  
Calcutta
- Therigatha  
Sadhana Library, Dacca
- Panchak-mala  
1910  
Sen Bros. 5, College Street, Calcutta
- Kalidasa  
1912  
Abinash Sarkar, 211, Cornwallis Street,  
Calcutta
- Tapasyar-phal  
1913  
Abinash Chandra Sarkar, 211 Cornwallis Street,  
Calcutta
- Sachchidananda - Granthabali  
1913  
Abinash Chandra Sarkar  
211, Cornwallis Street, Calcutta
- Jayadev-O-Gitagobinda  
1965 (Reprint)  
Sushil K. Sinha  
84A, Sambhu N. Pandit Street, Calcutta
- Bidrupa-O-Kalpa  
1948  
Kartik Ch. Datta  
211 Cornwallis Street, Calcutta
- Katha-O-Vithi  
1951
- Yajna-Bhasma  
1905
- Phula-sar  
1905
- Tiktiki  
1921
- Typical Selections from  
Oriya Literature  
(Vol. I, II, III)  
1923, 1925  
University of Calcutta
- The History of Bengali  
Language  
1920  
University of Calcutta
- History*
- Bharat-Varsher Itihas  
1926  
Published by the Author
- The Chauhan rules of  
Sonpur  
1925  
Published by the Author
- Orissa in the making  
1925  
University of Calcutta
- Sonpur in the Sambalpur  
Tract  
1911  
A. C. Sarkar  
211, Cornwallis Street, Calcutta.

(Papers)

Maranja-Mura Charter of Maha  
Siva Gupta Alias Yayati Reprinted  
from The Journal of the Bihar  
and Orissa Research Society  
Vol. II page 45-49, March 1916  
The Band Charter of Kanak  
Bhanja Deva (Circa 1475 A. D.)  
Reprinted from The Journal of the  
Bihar and Orissa Research Society  
Vol. II, September 1916  
Singhara Plates of Ranaka  
Ranabhanja  
December 1920  
Page 481-486  
Kumurukela Charter of  
Ranaka Satru Bhanja Deva  
(Circa 1323 A. D.) Page 429-435  
Vol. II, December 1916

*Ancient History*

The Origin and Character      University of Calcutta  
of the Purana Literature  
Sir Asutosh Mookerjee Silver  
Jubilee Volumes Reprinted  
from Vol. III (Orientalia) 1921

*Social Anthropology*

Aborigines of the Highlands      University of Calcutta  
of Central India  
1927  
Elements of Social      University of Calcutta  
Anthropology  
1936  
Yugapuja-O-Dharma Visvas  
1893

*Miscellaneous*

Reprinted from Indian Culture  
Page 565-597, Vol. II, No. 3  
"Amritam"  
Page 594-595

## II

**Mating System and Marriage**

'Still to-day the questions that most affect our well-being or even continuance on the earth as individuals, as families, as nations, or as a species,—the questions of heredity, eugenics, birth-control, sterilization, divorce, the place of woman and the care of the child,—they are all merely aspects of the central problem of marriage. Into the making of a proper account of marriage there enter biology, physiology and embryology, psychology, ethnography, folk-lore, the study of magic and religion, economics, law.'

Havelock Ellis

*The Biological Urges*

All living beings, mice or men, are guided by two fundamental biological urges. First is the urge for survival. It is primal and deeply rooted and is rather 'completely and uncompromisingly selfish' (Pearl, 1939). Its 'net accomplishments and final consequences' are quantitatively expressed by mortality rates.

The second is the reproductive urge and is really an extension of the first. It is measured quantitatively by birth rates. There are various forces which curb down its full expression in man and two of them, according to Pearl, are of particular importance in man. The first is legal, since mankind demands the legal rite of marriage as a pre-requisite to reproduction. The second restrictive force is hedonistic, commonly known as birth control. Mankind discovered it long ago, not out of the social welfare in general, but out of the same selfish urge connected with survival. As Raymond Pearl puts it: '... .. a desire on the one hand to have more fun out of life without having to pay for it, and a shrewd estimate that the chances of prolonged individual survival of self and children will be enhanced if there are too many of the latter'.

I shall try to go into details of these forces operating among the three high caste populations of Bengal, namely the Brahman, Kayastha and Vaidya.

I will first of all try to delineate the nature of the first restrictive force, namely legal, as seen in variations in mating

systems. It is worth while however before all to discuss the socio-biological significance of marriage as it stands today among the above three caste groups. Divorce has complicated marriage and we have also divorce laws since 1948. Betterment of social conditions in the Western countries has not in any way decreased the frequency of divorce rates, rather there is a tendency to rise (Slater and Woodside 1951). There is a group of thinkers who speak of the bankruptcy of the institution of marriage though Westermarck (1936) has proclaimed that marriage as a social institution is bound to survive as a permanent feature of sex-relationship.

On the other hand, recent studies of animal behaviour, specially of the anthropoid apes, do not support the animal origin of the institution of marriage, which had its 'fundamental impulse' (Ciocco 1938) from the Darwinian theory of organic evolution. Ciocco rightly points out : '..... the human mating differs from that of animals not only because of the so-called super-organic factors, but because in man the economic, sexual, reproductive and companionship factors are all at the same time actually or potentially manifest'. He further says : 'that once the concepts of the suggested primeval pattern are discarded, their (Westermarck and Briffault) studies bear on the development of marriage in terms of the co-existence of the economic and sexual-reproductive factors.'

### *Birth Control*

Another complicating factor in modern marriage has been the practice of birth control, of which a brief mention was made before. It offers no challenge to the continuation of the institution of marriage as long as the reproductive urge is there. But complications are apparent when great thinkers like Bertrand Russell try to see sex and marriage separately. In his *Marriage and Morals* (1958) he writes : 'I think that all sex relations which do not involve children should be regarded as a purely private affair, and if a man and a woman choose to live together without having children, that should be no one's business but their own.'

An ardent supporter of Judge Ben Lindsay's companionate

marriage, Lord Russell elsewhere says: 'If the bonds of marriage are recognized as final and irrevocable, there is no stimulus to the imagination to wander outside and consider that a more ecstatic happiness might have been possible.' The same authority is also of opinion: 'At present a marriage is null if sexual intercourse is impossible, but children, rather than sexual intercourse, are the true purpose of marriage which should therefore be not regarded as consummated until such time as there is a prospect of children.'

These revolutionary ideas, which are beyond the norm of the average Westerner and are much behind that of this country, are gradually pervading the minds of the young literates, who are always forward to quote Russell, but it boils down biologically to the same selfish motive of urge for survival.

Lord Russell speaks of the impossibility of 'more ecstatic happiness' in the case of fixed bonds of marriage, but let us see what Hedy Lamarr, 'the most beautiful woman of the century,' has to say of ecstasy in her autobiography (Lamarr, 1967). Hedy Lamarr 'had six husbands and on a rough count 150 lovers.' She had an ecstatic life and now at her age of 51 years, she is 'going without food for days'. And she states: 'I think most American women dislike men and the man they dislike most is their husband'.

Ecstasy, how so ever temporarily delightful it may be, is associated with a morbid state of nerves as in a trance or a frenzy. It is probable however that ecstasy has different points of view for a man and a woman. And can temporary delights, specially those related to sex life, lead to anything tangible towards human happiness? On the other hand, such ecstatic behaviours in a society are likely to bring in sexual competition among its members, which is never good for their integration. It will no less hamper the growth of personalities. Simpson (1965), has rightly observed: 'A basic problem for all of us is the integration and ethical development of our own personalities.' His definition of man, namely, 'Man is a normal animal', is probably better than qualifying man as a 'tool-making animal'.



### *Women and Marriage*

The woman's point of view of marriage and family appears to be the guiding factor in marital happiness. Ciocco (1938) in analysing the cohesive and disruptive factors in a marital group of 390 American women found that 'over 70% of women have no intention of breaking their marital ties'. And 'the number of women who desire to take active steps to correct the situation and eliminate the conflict is greater than the number of those who apparently have a definite desire to end the marital union.'

The above study led Ciocco to hold that 'marriage is essentially an economic and sexual-reproductive union' and 'cannot be regarded simply as a manifestation of man's acquiescence to social pressure. Its far deeper foundation is so obvious that only few of the women express the need to rationalize about their desire to stay married or to justify this desire by introducing religious or ethical principles'. This 'far deeper foundation' is probably the same urge for survival which is justified by the ethics of maternity. The desire for maternity alone guides a woman to accept a man. That urge alone causes her to surrender to a person unknown. That is why women are endowed with so much forbearance. There are signs of the gradual waning of this forbearance in the present-day industrial civilization and along with the emancipation of women. Cajal (1951) pointed out long ago that 'as soon as she enjoys a talent and culture ordinarily thought of as belonging to men, a woman loses the charm of modesty, acquires dominating airs and lives in a perpetual state of exhibition of her cleverness and ability.'

This change in women's attitude and behaviour, which is more often directed towards the child than the male, causes no less change in fertility. Some women get themselves sterilized before the birth of any children. The joint enquiry into birth control practices by the WHO (1957) and the Government of India revealed 13 cases of such women in the Lodi Colony, New Delhi. A few such cases are also known to me as a result of a private enquiry in Delhi during 1950.

Emancipation of women is destroying their modesty just as intemperate birth control practices, which hinders resistance to a number of toxic agents, are robbing their beauties. Soon they are transformed into 'dried-up old spinsters', an analogy used by Axel Munthe (1960) for the moon.

### *Selection in Marriage*

Marriage among the three upper castes of the Bengali Hindus is controlled by exogamous *gotras* though there are a few instances of marriages within the *gotra*. The usual practice is to avoid seven generations from the father's side and five generations from the mother's side. This rule of avoidance appears to have been laid down in Hindu society of North India rather late, since the age of the *Dharmasutras* (600-300 B.C.). Later on it was enforced by Manu. Kapadia (1955) has reviewed the ancient literature and is of opinion: 'It is quite clear that in the *Dharmasutras* and *Manusanhita* marriage of cross cousins, which was allowed in the time of Brahmanas, had come to be discredited and upheld as proper only in those parts of the country where they could be justified because of the peculiar social conditions'. Kapadia also points out that cross-cousin marriage was practised by 'the outlandic Indo-Aryan peoples' outside the middle region or Madhyadesa. Kapadia appears to disagree with the restrictions of the Hindu Code Bill, which lays as a condition of valid marriage for persons outside five generations on the father's side and three generations on the mother's side, unless permitted by local custom. Kapadia writes: 'As a matter of fact, in these days when individual choice of a partner in marriage has come to be recognized as necessary and desirable even by the older generation, any artificial shackles in the form of exogamous restrictions are outmoded. It is to be desired that in the Act when it emerges, this *sapinda* exogamy may be restricted to three generations on both sides. This legal narrowing down of the prohibited degrees does not prevent any person avoiding five or even more generations if he so chooses, but it removes unnecessary restriction which have no cultural or biological significance'.

This takes us to the incest taboo and the mating systems of some animals. In the various species of Protozoa, the usual form of reproduction is the fission of the body into two halves. But in the process of conjugation two animals from the same clone rarely come together to conjugate, rather they are from two different clones. Corner (1947) in describing late Professor Jenning's observation of this fact in *Paramecium bursaria* writes : 'By studying an immense number of animals of the species *Paramecium bursaria*, the investigators found that the whole population of the species is distributed into several "mating types" such that an individual of one type will mate with one of another type, but not with one of its own'.

The Canada Goose (Aberle *et al.* 1963) is again an example of outbreeding, *par excellence*. Among these birds, individuals from other families only mate. Siblings and opposite sexed parent are avoided. Aberle *et al.* write : 'The luckless breeder who takes a male and a female from the same brood to raise geese is doomed to disappointment : the pair will not mate even if no partners are available. If, however, two members of the same brood are separated before hatching occurs and are subsequently re-introduced to each other having been raised the different families, they may become mates'. It has also been pointed that 'close inbreeding might not be deleterious to animals which mature quickly and have numerous offspring'.

As regards inbreeding in man Aberle *et al.* say : '...as we move from (biologically defined) second cousin matings to first cousin matings to parent-child or sibling matings, both the models of population genetics and the experimental and observational evidence from animals indicate that the reduction of heterozygosity increases rapidly, and hence that the percentage of individuals homozygous for lethal or deleterious recessive genes also rises sharply.'

The second cousin matings mentioned above obviously fall into fourth generation and as such Kapadia's advocacy of third generation from each parent is not biologically sound. We have no statistics regarding the frequency of the different types of marriages following the different rules of avoidance. Only a National Commission on Marriage can provide such information. In fact the many Marriage Acts, beginning with

the Widow Remarriage Act of 1856 to the Hindu Code Bill of 1948, were not preceded by any scientific enquiry as done by the British Royal Commission on Population, 1945-47.

Let us now see how far the rules of avoidance in marriage among some castes have been violated.

Mrs. Bela Gangopadhyay (1964) has provided us with some data as regards the rules of avoidance not followed in marriage. Her data comprise the following Bengali castes: (1) Brahman, (2) Kayastha, (3) Gandha-banik, (4) Byagra-Kshatriya and (5) Hadi. Both rural and urban samples of the first two castes were studied. Gandha-baniks are mainly urban while the last two castes are rural and of lower social rank. A total number of 2854 marriages was examined and the pedigree method of study was followed all through. Gangopadhyay found 31 cases of violation of caste endogamy but remarked that the consanguineous marriages 'may be treated as deviations.'

Gangopadhyay found six instances of consanguinity, of which one belonged to Kayasthas, four to Gandha-baniks and one to Byagra-Kshatriya ('Tentulia). Among Brahmans two instances of marriages between cousins related through step-mother were recorded (Fig. 1).

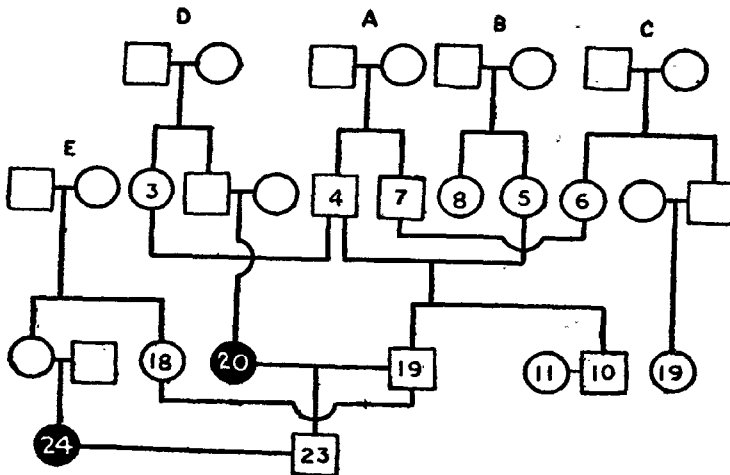

FIG. 1.

POLYGAMY AND MARRIAGE BETWEEN STEP PARALLEL & CROSS CONSINS ● (REDRAWN AFTER GANGOPADHYAY, 1964, FIG. 1: 4, SERIAL NOS. WITHIN SYMBOLS SAME)

The Kayastha consanguineous marriage (Fig. 2) was between

the children of two parallel first cousin sisters or two full second cousins. Gangopadhyay has not recorded any issue of the union but, assuming an offspring, its coefficient of inbreeding would be .0156.

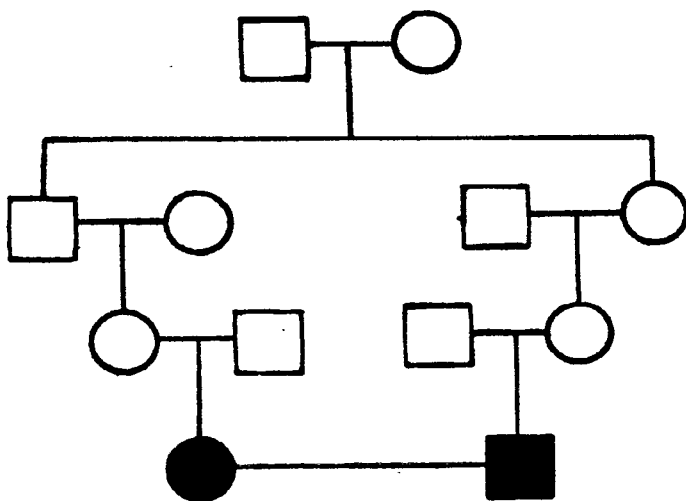

FIG. 2.

INBREEDING AMONG DAKSHINA-RADHI  
KAYASTHA (AFTER GANGOPADHYAY, 1964)

The four Gandha-banik consanguineous marriages are shown in Figs 3-6. The marriages shown in Figs. 3-4 are between a pair, genealogically related as uncle and niece or full second cousins once removed. Both show the same co-efficient of inbreeding (.0078) if offsprings are assumed.

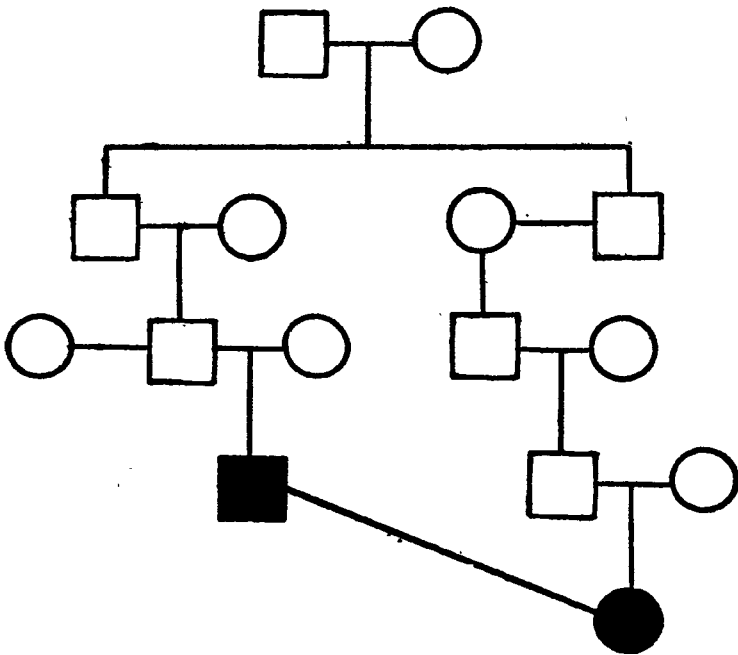

FIG. 3.

INBREEDING AMONG GANDHA-BANIK  
(AFTER GANGOPADHYAY, 1964)







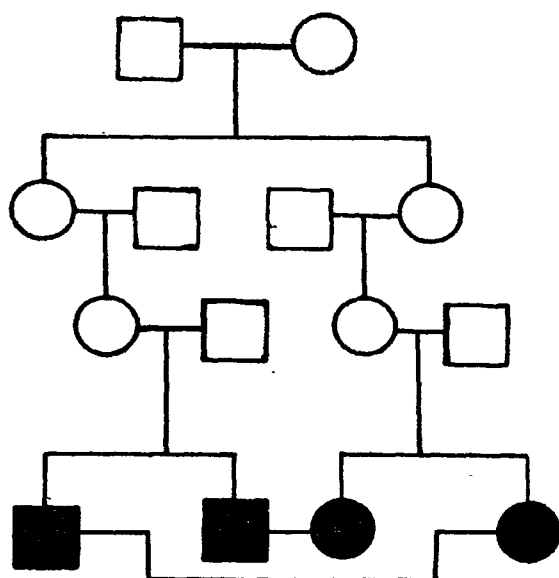

FIG. 6.  
INBREEDING AMONG  
GANDHA - BANIK

The co-efficients of inbreeding for the four Gandha-banik consanguineous marriages therefore vary between .0078 and .0156, showing an average of .0117. The total population of this caste is not known but it is mainly confined to towns and the city of Calcutta; where they get better opportunities for

trade. About 95% of Gangopadhyay's data are from the city of Calcutta. It appears to be a small population.

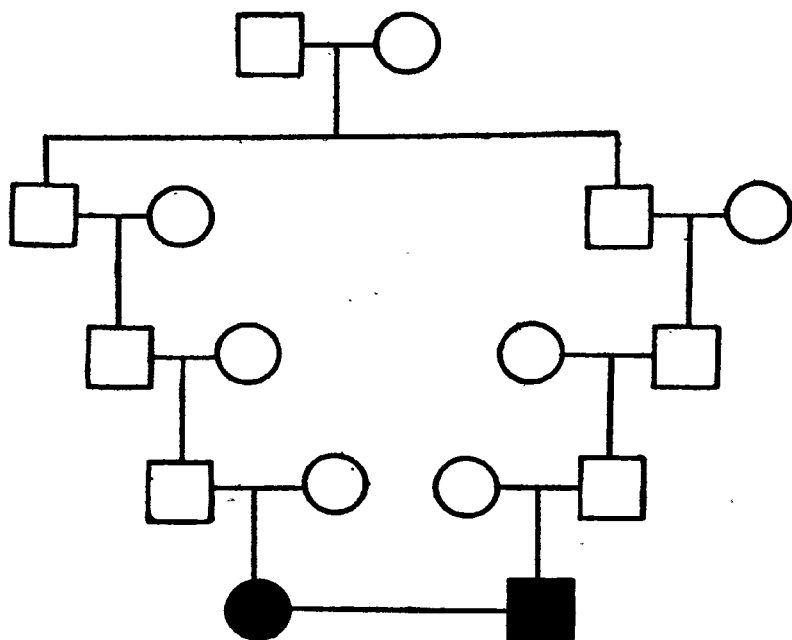

FIG. 7.

INBREEDING AMONG  
BYAGRA - KSHATRIYAS

Fig. 7 shows an instance of inbreeding among the Byagra-Kshatriya between full third cousins. The co-efficient of inbreeding for an assumed offspring would be .0039.

The rates of inbreeding are therefore as follows :

Kayastha	—	$1/518 = .0019$
Gandha-banik	—	$5/573 = .006$
Byagra-Kshatriya	—	$1/457 = .0021$

Apart from the above data, the present author is aware of two matings between full first cousins among the Dakshin-

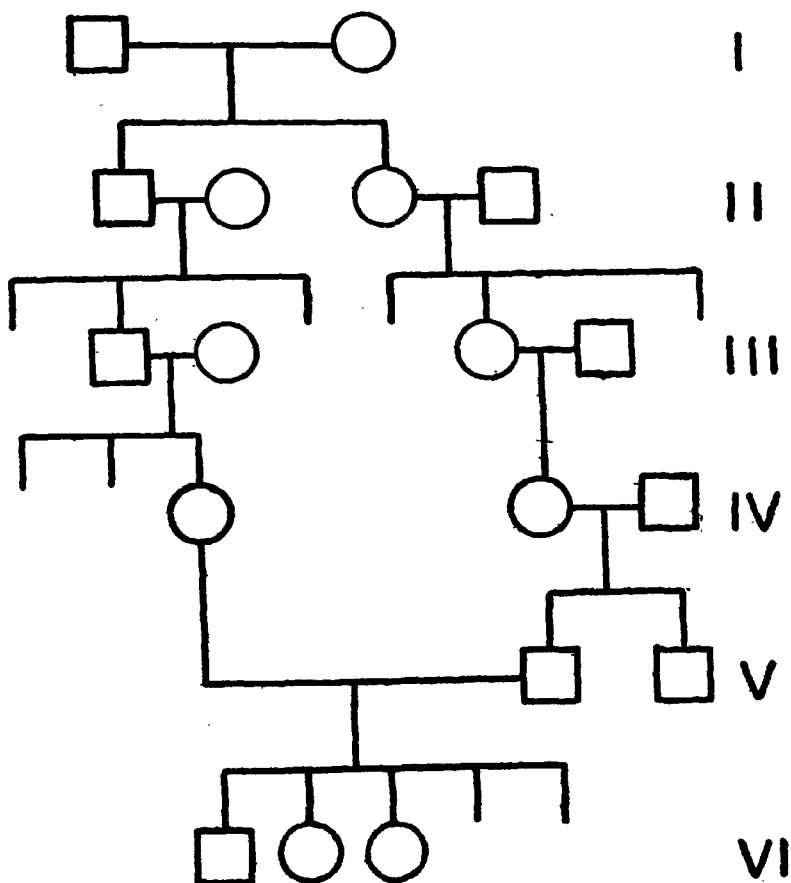

FIG. 8.  
INBREEDING AMONG  
DAKSHIN BARHI KAYASTHA

Rarhi Kayasthas who would show the highest inbreeding co-efficient of .0625 in case of an offspring. Another case (Fig. 8) of inbreeding from among the same Kayastha caste showing a mating between two second cousins once removed shows a co-efficient of .0078 (Sarkar 1967). The average co-efficient for the Dakshin-Rarhi Kayasthas, for all the four matings mentioned above thus comes to .0337.

It must be mentioned here that I have assumed an offspring for the calculation of the co-efficients of inbreeding, but there are some evidences of complete control of progenies in a few cases of inbreeding. It may be due to lack of recognition of such offsprings in the society. It is however difficult to distinguish the above social obloquy from the selfish urge (usually on the part of males) and involuntary sterility. I have known a few instances of childless marriages, the difference of ages between the partners of marriage being very high. Usually the husband is between 40-45 years while the wife is between 20-25 years. Such marriages appear to be frequent among urban literates and only a National Commission on marriage will be able to find out its frequency.

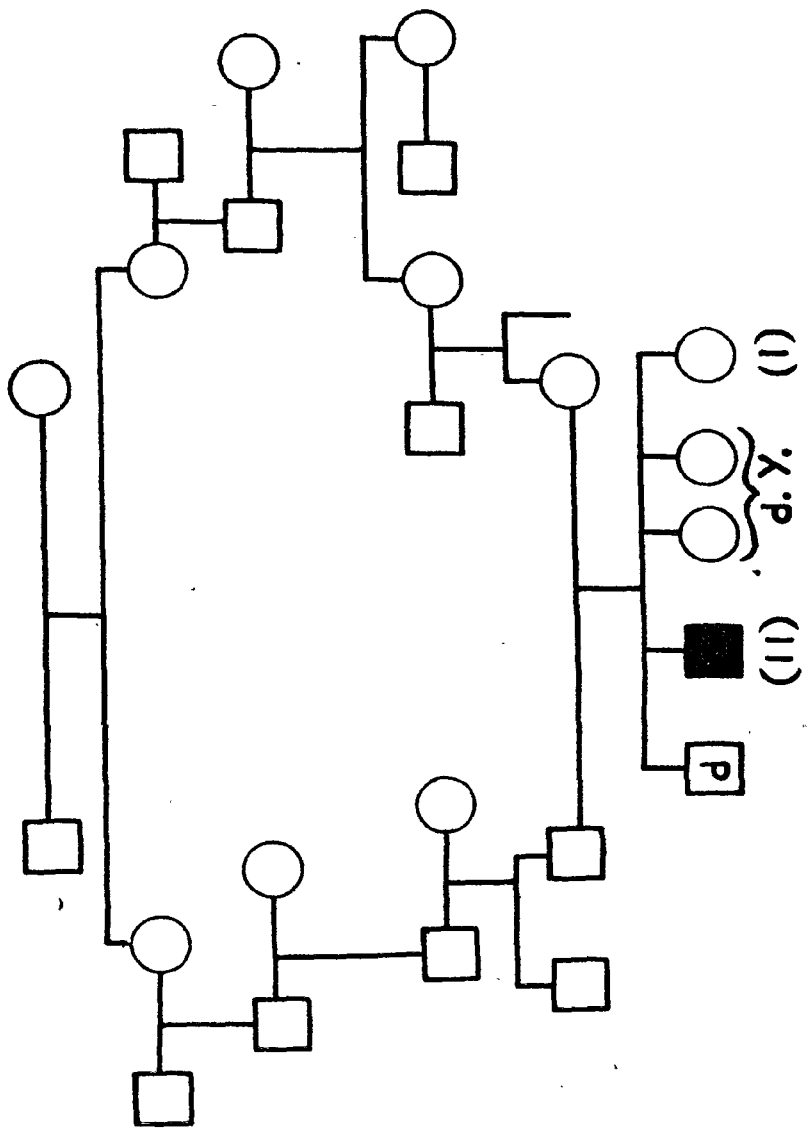

FIG. 9:  
INBREEDING AMONG  
BAIGA OF MADHYA PRADESH

A full third cousin mating (Fig. 9) was also reported by Sarkar (1967) among the Baiga of Madhya Pradesh. It showed the same co-efficient of .0039 as the Byagra-Kshatriya.

Cousin marriages are more widely practised in South India and Maharashtra than in North India. Kapadia has summarized the various instances of cousin marriages in the *Mahabharata* and in other literary writings. In eastern India it has been traced in the Sakya family in which both Buddha and his father married their mother's brother's daughters. These marriages should not be overlooked as merely exceptional but might be traits of an old culture once widespread throughout India. Various explanations have been offered for the justification of cousin marriages and Kapadia says 'that by the 7th century A. D. marriage with a cognate in the third generation had become so undesirable that the old traditions in favour of it had to be explained away by saying that such marriages were either conditioned by circumstances or that they were not really marriages with one's cross-cousins.' The custom thus appears to have been out of vogue in North Indian Hindus rather recently, but Muslims and Christians have been practising it even now.

Dronamraju (1960) and Sanghvi (1965) have provided some data on inbreeding frequencies from South India. Ghosh (unpublished) has been working on the Kota of the Nilgiris, who practise cousin-marriages, and I am thankful to him for allowing me to use his unpublished data. From the Kota pedigrees so far analysed, the average co-efficient of inbreeding for the Kota appears to be .0321. The inbreeding co-efficients so far known from India are given in the table below :

TABLE 1

*Inbreeding Coefficients*

Locality	Sample	Coefficient	Author
Andhra Pradesh	Married in-patients of King George Hospital	.028	Dronamraju

Table 1 (Cont.)

Locality	Sample	Coefficient	Author
Vishakapatnam	Parents of School Children	.019	"
Audhra Pradesh	Rural	.032	Sanghvi
		for autosomal genes	
do.		.051	"
		for sex-linked genes	
Bombay	Brahmin, Kayastha and P. Prabhu	.001 - .003	"
do.	Maratha, Agri and Mahars	.005 - .007	"
do.	Muslim, Parsi	.006 - .013	"
do.	Christian	.001	"
West Bengal	Kayastha	.034	This study
do.	Gandha-bank	.012	Gangopadhyay
do.	Byagra Kshatriya	.004	"
Madhya Pradesh	Baiga	.0014	Sarkar
Madras	Kota	.032	Ghosh

Geneticists have clarified the old theory of inbreeding, which was held to cause deterioration of the stock. Inbreeding does not cause any deterioration of the stock but brings to light the deleterious and lethal recessive genes.

The effects of cousin marriages in South India have not been studied and the nature of the deleterious recessive genes is therefore not known. Inbreeding however brings in homogeneity in the population which is however much more marked in South India than in the North. This is again a problem for the proposed National Commission on Marriage.

The few cousin marriages known to me are the results of personal choice and as such partly falls within assortative mating. Obviously the similarity of the partners in physique, in temperament and in many other factors was the basis of liking. Some authorities (Slater and Woodside 1951) prefer

assortative mating for the betterment of society. They say : 'It tends to increase the variability of the population, to increase the numbers of persons showing an extreme degree of a quality, and to decrease the proportion of persons near the average.' They are all quite good for the betterment of the society but can we make an assortment in a human society ? A society bound up by traditions has a limited choice and can rarely be random in nature. Rather better assortment was practised in contracting marriages in early Hindu society, where marriage distances were far greater than what it is at present. The range of exogamy appears to be gradually shrinking.

### *Intercaste Marriages*

The range of exogamy and endogamy vanishes with intercaste marriages. Gangopadhyay has come across nine cases of intercaste marriages out of 2854 marriages (3.2%) but did not mention the castes of both the partners contracting marriage. Her data however show higher frequency of Kayasthas than the other castes. She found two cases among Brahmans, three among Kayasthas, one among the Gandhabanik, two among Byagra Kshatriya and one among the Hadi. There is no earlier data to compare with Gandopadhyay's findings.

In Bombay however intercaste marriages appears to be gradually increasing as the following table from Kannan (1963) show.

TABLE 2  
*Frequency of Intercaste marriage in Bombay*

Year	Frequency	Percentage
1917	1	0.4
1926-30	1	0.4
1931-35	5	2.0
1936-40	8	3.2
1941-45	17	6.8
1946-50	58	23.2
1951-55	85	34.0
1956-59	75	30.0
	<hr/> 250	<hr/> 100.0



The sudden rise of the frequency from 6.8% for the year 1941-45 to 23.2% during 1946-50 is due, according to Kannan, to the Hindu Marriage Disabilities Removal Act of 1946 and the Hindu Marriages Validity Act of 1949. The castes involved in the above data are not also available.

The present author has at his disposal some data on 34 intercaste marriages from among three high castes of Bengal, which are presented below. The Brahman data could be subdivided into the three endogamous division, namely, Rarhi, Vaidik and Varendra. As in the case of Gandha-baniks, the total population of these three subdivisions of Brahmans are not known but the latter two groups are numerically much less than the Rarhi. The data are as follows :

TABLE 3

*Scheme of Intercaste Marriage*

	Male	Female
1. Rarhi Brahman	a	b
2. Vaidik Brahman	a	b
3. Varendra Brahman	a	b
4. Kayastha	a	b
5. Vaidya	a	b

If each caste is numbered according to the serial numbers given above and the two sexes of each caste as  $a$  for male and  $b$  for female then there is possibility of 20 matings. The frequency of these 20 matings is as follows :

TABLE 4

*Frequency of Intercaste Marriages*

Rarhi Brahman	1a × 2b	—	0
	1a × 3b	—	2
	1a × 4b	—	2
	1a × 5b	—	3
			<hr/>
			7
Vaidik Brahman	2a × 1b	—	0
	2a × 3b	—	1
	2a × 4b	—	2
	2a × 5b	—	0
			<hr/>
			3
Varendra Brahman	3a × 1b	—	0
	3a × 2b	—	0
	3a × 4b	—	2
	3a × 3b	—	1
			<hr/>
			3
Kayastha	4a × 1b	—	3
	4a × 2b	—	1
	4a × 3b	—	4
	4a × 5b	—	6
			<hr/>
			14
Vaidya	5a × 1b	—	2
	5a × 2b	—	1
	5a × 3b	—	0
	5a × 4b	—	4
			<hr/>
			7
			<hr/>
			34

The above table will give an idea of males of each caste while that of females will be seen below.

TABLE 5  
*Women involved in Intercaste Marriages*

Rarhi Brahman	—	5
Vaidik Brahman	—	2
Varendra Brahman	—	7
Kayastha	—	10
Vaidya	—	10
		34

Though nothing could be said out of such small data, it is probable that Kayastha males are more prone to intercaste marriages than the other castes. The same is borne out by the Kayastha females as well, although their number agrees with Vaidyas. Gangopadhyay also found the highest number of Kayasthas in her sample. The Vaidik Brahman group shows the lowest frequencies for both sexes but the higher number of Varendra Brahman and Vaidya females than the respective males is noteworthy. Anything may however happen with a small sample and the above observations are merely explanatory in nature.

The Kayastha males however occupy the lowest position when international marriages are taken into account, as given in table 6.

TABLE 6  
*Indian X European Marriages*

Brahman	(m)	×	European	(f)	—	16
Brahman	(f)	×	European	(m)	—	1
Kayastha	(m)	×	European	(f)	—	13
Kayastha	(f)	×	European	(m)	—	2
Vaidya	(m)	×	European	(f)	—	17
Vaidya	(f)	×	European	(m)	—	1

We require more data. Almost nothing is known of the various marriage practices although so many laws have been promulgated ; and a few of them are dead laws, so to say. Widow remarriage has not gained much currency among the three castes here discussed in spite of its being one of the first and the oldest law of the country. Gangopadhyay did not find a single case of widow remarriage in a total of 457 marriages even among the Byagra-Kshatriya of Howrah. Nor was it found among the same caste of a village in the district of 24-Parganas, West Bengal, as a result of enquiries by Miss Poddar (unpublished). On the other hand the existence of the law alone confuses western scholars like Stycos (Hardin, 1963), when he writes : ‘...in India, the break down on taboos on the remarriage of widows could lengthen the average reproductive period.’

I have already said that a National Commission on Marriage is the earliest desideratum before we have any applied programme on family planning or birth control. I proposed it in my presidential address at the Anthropology Section, Indian Science Congress, Bangalore, 1951. It has fallen on deaf ears. But if we do not want to know ourselves we are not scientists.

#### REFERENCES

- Aberle, D. F., Bronfenbrenner, Urie, Hess, E. H., Miller, D. R., Schneider, D. M., Spuhler, J. N. 1963. The Incest Taboo and the Mating Patterns of Animals, *Am. Anth.*, 65, 253-265.
- Cajal, S., Ramon, Y. 1951. *Precepts and counsels on scientific investigation : Stimulants of the spirit*—(Translated from Spanish), California.
- Ciocco, A. 1938. On Human Social Biology II. Disruptive and Cohesive factors in the marital group. *Hum. Biol.*, 10, 555-574.
- Corner, G. W. 1947. *The Hormones in Human Reproduction*, Princeton.
- Dronamraju, K. R. and Khan, P. Meera, 1960. Inbreeding in Andhra Pradesh. *J. Heredity*, 51, 238-242.

- Gangopadhyay, Bela, 1964. *Marriage regulations among certain castes of Bengal*, Poona.
- Hardin, Garrett 1963. *Population, Evolution, Birth Control*, San Francisco.
- Kapadia, K. M. 1955. *Marriage and Family in India*, London.
- Kannan, C. T. 1963. *Intercaste and Inter-community marriages in India*, Bombay.
- Lamarr, Hedy, 1967. Ecstasy and Me, (Review in *The Statesman*, 16 April 1967, Calcutta).
- Munthe, Axel, 1960. *The Story of Saint Michael*, London.
- Pearl, Raymond, 1939. *The Natural History of Population*, London.
- Russell, Bertrand, 1958. *Marriage and Morals*, London.
- Sanghvi, L. D. 1966. Inbreeding in India, *Eugenics Quart.*, 291-301.
- Sarkar, S. S. 1967. Two Pedigrees of Inbreeding from North India, *Man in India*, 47, 238-243.
- Simpson, G. G. 1965. *The Meaning of Evolution*, Calcutta.
- Slater, Elliot and Woodside, Moya, 1951. *Patterns of Marriage*, London.
- Westermarck, E. 1936. *The future of marriage in Western Civilization*, London.

### III

'Intemperance in every enjoyment defeats its own purpose'—T. R. Malthus

#### Population Problems

I, for one, am sick of hearing of population problems, policies and programmes. I find it in print in almost all technical and non-technical publications, on postage stamps, in post office cancellations, on the hoardings of railway stations and in various other forms. In spite of the Drugs and Magic Remedies (Objectionable Advertisement) Act 1954, quacks litter the Calcutta streets with handbills firmly pasted on electric lamp-posts. All mean birth control or the camouflaged unscientific term Family Planning. It is good that they are never read by poor peasants since they are not literate. Otherwise they would not have been hardy tillers of the soil to produce food for the white-collars of the city. West Bengal peasants are always short of labour during the sowing and the harvesting seasons and the tribal Santals are invited from the neighbouring areas to complete the work.

It was therefore a welcome relief to read Garret Hardin's Introduction to his beautiful collage, *Population, Evolution, Birth Control* (San Francisco, 1963). Let me quote him : 'More than a century and half ago, just shortly after the French Revolution, Thomas Robert Malthus published his essay on population, unleashing a storm of controversy which has continued unabated to this day. What's wrong? Why can't we solve 'population problem'? The reply, of course, is that there isn't any population problem; we conceive our trouble wrongly when we speak of it as a problem. The word problem suggests the word "question," and when we think of questions, we think of demands like this "What is 2 + 2?" Such demands are easily met. But the reticulum of trouble that we label 'population' is something else. As is often said in scientific research, our first problem is to find the problem. Failure to recognize this has contributed to the apparent immortality of the population problem. We have tried to answer questions when we should have been looking for them.' I will try to look for questions therefore. My answers may not satisfy all.

#### Question 1 : Is India overpopulated ?

Probably not—otherwise we would not have divided the country and admitted millions of refugees, mostly Hindus from Eastern Bengal and western Punjab. Further, with the annexation of Tibet by China, many Tibetans have taken refuge in India. Ceylon and Burma have also expelled many Indians who are now living here. If we had no space how could we allow so many immigrants? And of late several thousands of square miles of land have passed into enemy hands.

Then we have exterminated many villages and uprooted the sons of the soil therefrom for the sake of industries. I do not possess statistics for the whole of India but a few examples from West Bengal and Bihar will prove my contention. In West Bengal 10 villages were fully and 15 partially acquired for Chittaranjan Locomotive Workshop, Hindusthan Cable Factory and the Damodar Valley Projects. The total area of

the fully occupied villages is 9.1 sq. miles, while that of the partially affected ones is 8.8 sq. miles. The total population affected is 5426, all of whom could not be rehabilitated (Das and Banerjee 1962). The opening of the Haldia Port in Midnapur, West Bengal, has also costed more than a score of villages.

The Heavy Engineering Corporation, near Ranchi, Bihar has ousted about 25 villages having an area of about 14 square miles with a population of about 15,000 souls. Then there are many others in other States. Dam-sites have no less encroached upon villages and peoples. How could we do these if we were overpopulated and had 'no standing space,' in the language of some authorities ?

Then the density of population in India (1951 census) varies between 10 persons per sq. mile in the Andaman and Nicobar Islands to 1015 in Kerala, with an average of 281 for India. This density of population increased to 370 persons per square mile in 1961, which Maudlin (1967) calls 'very high' in comparison with a density of 'about 2000 persons per square mile of inhabited and cultivable land' for Egypt and an 'approaching density of 1000 persons per square mile' for Mauritius (Lorimer 1967).

In India there is still scope of reaching a uniform density of population since the average of 281 persons per sq. mile was not reached by no less than 20 out of 33 States.

#### **Question 2 : Is India self-sufficient in food ?**

Even this question cannot be clearly answered. We always hear of crop-estimates at the beginning of the season. I believe, all farmers are not compulsorily required to furnish reports of their actual produce of food-grains to any authority ; and unless this is known we will never know our actual position. It is true that we are importing food-grains from abroad, but a major part of it is spent in feeding industrial areas and even that inadequately as the quota of rations will prove. It is however often said that our food shortage is of very slender margin which could be bridged over with some effort on our part. We have not tried enough to increase food production

by improved methods of agriculture followed in the western countries or China or Japan. And we have wasted much of land for factories. Taking the examples of West Bengal and Bihar only, cited above, we have lost food produced by 35.50 villages and their food producers as well. And there was no alternative method to restore the food produced by the above villages. Even all the uprooted villagers have not yet been rehabilitated. They are a sort of internal refugees. Probably we thought of exporting machinery and buying food thereby, as is done in Japan. Then in our craze for road building we have dug deep, wide trenches for earth on either side of ill-made roads on agricultural lands. Neither agriculture nor fishery is possible in such places. There is no statistics for this loss of food, but it can be known. The poor peasants have never been compensated. On the other hand, these deep trenches have hampered agriculture in the nearby lands.

Then the amount of fallow land is still enormous. There has been public demand over the distribution of fallow lands to landless labourers. The latter were to receive land after the abolition of the zemindary system, but how many have got it? As such, taking the various factors into account it may be said that we have never been really serious in our attempt to attain self-sufficiency in food for the whole of India.

Then we have built more cities in these few years. Cities are a prehistoric heritage. They are centres where food is wasted and peoples with white-collar jobs are overfed. There is no specific hour of the day for food. Tea and snacks are taken at all hours of the day. Not to speak of vice and filth that accumulates with the establishment of a city, it is a phenomenon which the present civilization must abhor. Much can be said about the wasteful luxuries in cities, but this is not the proper place. The city, a prehistoric heritage, should be abandoned.

**Question 3 : Is birth control the answer ?**

I owe this question to Rev. Arthur MacCormack and Colin Clark (Hardin 1963). Many authorities have discussed it. There is no agreement between them. I would like to mention only a few points which occur to me as an anthropologist.



Firstly, all mothers at some stage of their lives realize the necessity of birth control. Popular beliefs also point out that both the old mother and the daughter or the daughter-in-law should not have children alongside. The old must stop. Then in almost all villages there are some quack midwives who are experts in annual removal of the embryo or the foetus. The old woman teaches the young girl all affairs of sex. This is also the case in Sweden (Myrdal 1945) and probably in France as well. In France, birth control first began in the rural farms wherefrom it spread into the city. Mechanical birth control is an abnormal practice in the sense that it deprives the couple of the fullest enjoyment due to the presence of an extra artefact. Man has always attempted to heighten the sexual pleasure through various ways, and if that is negated by birth control it can never be popular. As such it must be left to the individuals themselves.

The Government of India has however vigorous birth control plans under the cover of Family Planning, and much of it has been due to our acceptance of foreign aid from the U. S. A. Hardin (1963) informs us as follows :

'In 1959, a President's Committee to study the U. S. Military Assistance Program, under the chairmanship of General William H. Draper, issued a report in which they pointed out in most delicate language—that foreign aid would have to be accompanied by birth control if the good effects of the aid were not to be nullified by excessive population growth. It was proposed that the United States furnish birth control information *on request*.'

President Eisenhower did not then agree, but in the fall of 1963, he had second thoughts on which Hardin remarks: 'As this book went to press, at the end of 1963, Congress was threatening to cut the Presidential request for foreign aid 40 per cent. How much was the thinking behind this action influenced by considerations of population and birth control? It may be a long time before we know, because contraception is so politically sensitive an issue that the legislator whose vote is influenced by population theory may feel it would be political suicide to admit as much.'

But total birth control can probably solve overpopulation, but only a few want it (though it should be in some cases if family planning is meant in the strict sense of the term). The trend in the present literate families of Bengal cities is to have a few children, majority only one, or follow the advice of the Indian Government : 'Don't postpone the first, don't hurry up the second, and don't go in for the third,' but to have more servants. 'Baby in the nursery and Baby Austin in the garage' has been the ideal of many an elite. The mother does not like the responsibility of the child. In such cases the mother depends more upon aids of others than her own.

To have more servants has been the ideal of the day in Indian cities. If we want more servants we cannot have birth control for them. The position is nearly similar to that pointed out by Bertrand Russell. He says that in England Mrs. Margaret Sanger's pamphlet on birth control was declared obscene but not Mrs. Marie Stopes books. Russell remarks : 'The consequence is that, while it is permissible to teach birth control to the well-to-do, it is criminal to teach it to wage-earners and their wives' ; for that would lessen the number of men for menial jobs. Servants are again a curse of the city and of luxury. It is a pitiable waste of man-power particularly when they abound in hundreds, as can be seen in any Government office. Incidentally, are all of them actually necessary for the office? Majority of them hail from villages and their return there would be useful.

To sum up this small review ; I feel that birth control should be left to individual choice, since, firstly there is no equivocal answer to our query ; secondly, its mass propaganda is useless because the mass is not as much educated as to decide whether it is good or bad for him ( it is good if he can afford servants, it is bad if he cannot afford any) ; and thirdly, it is harmful for healthy sexual life, which is of immense value for social health. Erik Agduhr's (1942) researches on hormones indicate the effect of normal sexual functions in raising the resistance to a number of toxic agents, e. g., paratyphus culture, diphtheria toxin in both the sexes. Normally reproducing couples are comparatively free from disease. If normal sexual

functions can heighten the resistance we may expect also the contrary, i.e. lowered resistance due to abnormal sexual functions.

Finally, I may be allowed here to quote a paragraph from Colin Clark's interview with Gandhi in November 1944. Clark writes: 'The greatest Indian of all time had no use for contraception. He opened the conversation with me in an unexpected manner'. "Do you know what is really the matter with the Indian people, Mr. Clark?" he asked me. "No, Mahatma," I replied. "They are thoroughly idle—they won't work," he said. If Indians made the necessary effort, they could grow all the food they need; *but without the stimulus of population pressure and economic need they will not make the effort.*"\* Gandhi spoke on this subject with remarkable frankness. He considered that the efforts which Mr. Nehru was making at that time to ration food and to bring down prices were quite mistaken. "Only if food prices were higher" he said "would Indians work hard enough."

I have quoted the above to show the inherent idleness in us through the words of Gandhi. To me it appears to have increased all the more since 1947.

Let us digress a bit as to the world situation with reference to overpopulation and food resources. I again quote the Oxford economist, Collin Clark: 'Let us now really consider the questions of economics involved. It is a very sad thing that so many prominent scientific and literary men, accustomed always to testing all their evidence most strictly when working on their own subjects, are nevertheless content to rely on the wildest hearsay when making public statements on the subject of food and population. Once, in a controversy in the *Manchester Guardian*, I challenged Doctor A. V. Hill to re-examine the evidence on which some of his statements<sup>1</sup> about hunger and overpopulation were based and then to state whether he considered it satisfactory; but he did not reply. How many of those who parrot the phrase about two-thirds of the human race living in a state of hunger are aware that although it is true that it once appeared in an F. A. O. publication,

---

\* Italics mine.

nevertheless it originated in nothing more than an arithmetical error on the part of a prominent propagandist, who confused two columns of statistical table<sup>2</sup>. It is true that the diets of a great many of our fellow-men may be inordinately dull, by our standards, but it is quite wrong to describe them as living in hunger.'

Even the last Director-General, F. A. O., used the above propaganda material very recently. Clark has rightly titled the sub-heading of the above quotation 'A question of morals or of economics?' According to Clark the agricultural resources of the world are enough for ten times the present population of the world.

A very logical answer to my third question was long ago given by Raymond Pearl (1939) after an exhaustive review of 'The Effects upon Natural Fertility of Contraceptive Efforts.' I quote him *in extenso* :

'Is the obliteration of existing fertility differentials what those who people the earth want? Or is a new pattern of fertility differentials, planned by the eugenists in their wisdom, what those who people the earth want, or merely what the eugenists want? *Those who people the earth, and they alone, will in their own good time decide.*'\* As far back as history goes men have never been lacking to allege that they knew what was best for humanity. But steadily and surely, if very slowly, the mass of humanity—those who people the earth have themselves decided, ever more and more, what they themselves thought they wanted, and have proceeded in ever increasing degree to get it. Their desires have often been foolish and

- 
1. Professor Hill's actual words published in *Manchester Guardian* of November 17, 1965 were : 'Already more than two-thirds of the existing population have too little food for a healthy life, many are continually half-starved, many are in periodical danger of starvation.' (Hardin, p. 270).
  2. The full, evidence for this extraordinary happening is set out in *The World's Food* (New York, 1954) by M. K. Bennett, Director of the Food Research Institute at Stanford and a recognized authority. Neither the writer in question nor F. A. O. have issued any reply to Dr. Bennett's criticism. (Hardin, p. 271).

\* Italics mine.

sometimes plainly harmful, even to the extent of threatening the survival of the whole enterprise of human living. But such errors of judgement have not altered the dominant characteristic of human social evolution—the awkward, terribly slow and stupid, muddling, but steady progress of mankind in the mass towards the control of its own affairs. When fertility differentials change their patterns, as they may in the future, just as they have in the past, it will most likely be because the breeders—those who people the earth—decide that it will be to their personal advantage and self interest to alter their breeding habits, and not for any other reason.'

But I have another question which may be considered as subsidiary to question No. 3.

**Question 3(a).** Is the slogan of the Indian Government rightly said ?

The slogan is quoted on another page and need not be repeated here. It says firstly 'Don't postpone the first.' Postponing the birth of a child cannot have equal emphasis for all kinds of mothers. If the wife is above 30 years of age there is no question of postponing the child since she might not be still fertile. But irrespective of the age of the wife, an early child destroys marital happiness and in the case of young wives one must wait for at least 3-4 years. Wives below twenty years of age may also have the advantage of the adolescent sub-fertility interval and contraception may not be necessary.

The second part of the slogan, 'Don't hurry up the second' is well said. One must not hurry up in any work. But the point is, can we plan a biological event like conception? Lewis Fanning (1949), who wrote the Family Limitation Section of the Royal Commission on Population of Great Britain, says that 'the majority of the unwanted children came from families where birth control was stated to be used. The percentage of women using control who had one or more unwanted children ranged from 27 per cent in the 1910-1919 marriage cohort to 21 per cent in 1930-34 marriage cohort whereas the corresponding percentage of women not using control varied from between 4 and 11 percent.'

Again, 'on the average, about 3 per cent of birth controllers definitely had families of smaller size than desired. They had abandoned control to have a child, without success. There is also a further 11 per cent, a considerable proportion of whom are likely to have desired larger families since, when questioned, they had used no control since the previous pregnancy.'

It is clear therefore that one cannot have a child according to his or her will. Conception is a complicated biological process and it cannot be always planned. Variability in the reproductive behaviour of women is caused by a host of factors, such as, irregularity of menstrual cycles due to age of women and seasons of the year. Pregnancies are possible without a menstruation during the lactational period and pregnant women may also menstruate thereby causing the spofoetation of another foetus resulting in a twin pregnancy. The greater birth interval of the rural women when compared to urban ones is difficult to explain. Tulika Sen (1953) found a mean birth interval of 2.94 years for the rural Bagdi women in comparison 2.56—2.60 years among the high caste Bengali women of the city of Calcutta.\* The joint enquiry by the W. H. O. and the Government of India found a birth interval of 3.5 years among the rural women of Ramanagaram, Mysore. It is a puzzle how could these rural women probably having no knowledge of birth control have a birth interval of 3—3.5 years. It is probable that cultural factors play a greater role than birth control.

The third part of the slogan is a complete denial of the child. If sterilization is not resorted to, there are chances of unwanted children among the birth controllers as well. But the greatest bar lies in the fact that the chances of death have not been taken into account. It is difficult to think that all parents, blessed with two children, will not lose any one or both of them. Then such a uniformity will be an easy prey to natural selection and mutation. Variation is an important factor in evolution.

---

\* The difference between the means is statistically significant.

Compared to the above slogan, I beg to offer the following three rules, which if adhered to, might be of biological and social value :

1. Marry early ; avoid having a child within 3-4 years of marriage.

*Note* : Take advantage of adolescent sub-fertility.

2. Try to avoid having a child within 2-3 years of the previous child.

*Note* : Fertility wanes with age.

3. Avoid having children after 30-32 years of the wife's age.

*Note* : Multiple births, monsters, mongolian idiots, are largely born at the high ages of the mother.

Let me conclude this part with a quotation from Raymond Pearl again : 'But the essence of the matter, for students of population at the present time, is the physical impossibility of the indefinitely continuous and synchronous growth of both population and altruistic behaviour in a spatially limited universe.'

### *Checks on Population Growth*

The checks on population growth are known as Malthusian checks or Neomalthusianism. On this fact Garrett Hardin writes : 'Malthus was adamant in insisting that sexual behaviour within marriage must not be impeded by unnatural devices. \* \* \* It is rather curious, therefore, that birth control movement arising in the nineteenth century should have been called 'neomalthusianism' an identification that must surely have made Malthus turn in his grave.'

But the man who first suggested checks on the growth of population was Verhulst, who discovered in 1838 the familiar S-shaped curve, known as Logistic curve. Verhulst and his Logistic curve were forgotten until the rediscovery of the latter by Raymond Pearl and L. J. Reed in 1920. Verhulst however suggested that the checks on the growth of a population increase in proportion to the population itself. Quetlet,

Verhulst's teacher, 'assumed by analogy with the resistance of a medium to the passage of a projectile, that the resistance to the growth of a population increases in proportion to the square of the velocity with which the population tends to increase.' This means that the greater the rate of growth of a population the greater will be the resistance offered to its growth. I am not aware of any earlier study in which systematic attempts have been made to study these checks on population growth although many such checks as, widow remarriage, infant mortality, complete sterility, war, epidemic, etc., are known. I will try therefore to offer here a discussion of such population checks, which, first of all, may broadly be divided under three categories : (a) biological, (b) sociological and (c) psychological.

The factors under the psychological category have obtained the least attention while those under the sociological one have of late been recognized. The position of the biological factors appears to be intermediate between the two.

**(a) Biological :**

1. *Infant mortality* : Regional, secular or innate biological variations in infant mortality and its variation at the different age-groups bring about first of all a swing in sex ratio at the different age-groups. Unfortunately in West Bengal in almost all age-groups among the three Hindu upper castes there is a preponderance of males over females. This is not a healthy sign for a growing population. The Census Commissioner, 1931, noted a steady fall in sex ratio since 1901 for the whole of India. He also wrote that 'the number of females is adequate to the number of males is limited to the ages from 15 to 30.' But this is not borne out from the following tables, which show higher number of males than females at all age-groups among the three Hindu upper castes.



TABLE 1  
*Civil Status and Age Groups of Three Bengali Castes (After Census of India, 1931)*

Castes	Age group in years	Unmarried		Married		Widowed		Sex Ratio (3)	
		Male	Female	Male	Female	Male	Female	Male	Female
Brahman	0-13	242980	209585	8430	26887	879	1086	54.1 Diff = 8.2 ± .0004	45.1
	14-43	188892	16474	255032	246868	14710	61914		
	44+	3535	879	98607	83665	24448	70198		
Kayasths	0-13	266635	237662	9838	22202	666	1069	52.6 Diff = 5.2 ± .0004	47.4
	14-43	152849	16563	239856	276125	13063	67319		
	44+	2914	640	113591	37536	20890	79434		
Vaidys	0-13	19066	18929	772	1162	24	62	52.0 Diff = 4.0 ± .0014	48.0
	14-43	12367	3629	14922	17592	888	3381		
	44+	230	61	7877	3361	1481	4936		
West Bengal (1951)		Males		Females		West Bengal (1951)			
	15-24	241,871		214,006		58.8		46.2	
	25-34	224,626		168,229		Diff = 7.6 ± .0001			
35-44	161,074		115,252						

TABLE 2

*Details of the Unmarried Reproductive Age Group (14-43 years) (after Census of India 1931)*

Age groups in years	Brahman		Kayastha		Vaidya	
	Male	Female	Male	Female	Male	Female
14-16	44397	10439	47254	10961	4063	2364
17-23	65016	3877	72515	3660	5651	908
24-43	80479	2158	33080	1942	2653	357
Total	189892	16474	152849	16563	12367	3629

How far this is due to the mortality of the females at the different age-groups is unknown, but obviously modern medicine has not been able to reverse the sex ratio. It might be pointed out here that although modern medicine has reduced mortality of tuberculosis, its morbidity has increased, which according to Bottiger, Nordenstam and Wester (1962) may even increase. Tuberculosis has been dangerously recessive in many families and many authorities have sounded warning about its gradual increase with industrialization.

2. *Natural checks on fertility of women* : Natural factors affecting female fertility have been the subject of a few studies. Goodhart (1956) has given a list of such factors of natural forces selecting fertility.

It is worth quoting him : 'In man, multiple births are rare, women are fecund for only about half their lives, conception may be inhibited during lactation and more or less complete sterility is surprisingly common. These checks on fertility must be the result of natural selection, for if there had been any real overall selective advantage in higher fecundity it could have been evolved. Women are well adapted anatomically for nursing twins, and the tendency to have them is certainly inherited so that their comparative rarity must mean that, owing probably to higher mortality, there can be no real selective advantage in multiple births, even though, potentially they could increase fertility.' Hardin (1964) also maintains the influence of natural selection in increasing the irregularity of human ovulation. In a recent survey by Jaya Choudhuri among high caste urban girls it was found that urban girls have more irregular menstrual cycles than their rural counterpart (unpublished).

3. (a) *Differential fertility* : It has been often claimed that the poorer classes have a higher fertility than the rich. The Census of India, 1931, found a higher average number of children (4.4) per family for the producers of raw materials, while an average of 3.7 for those practising law, medicine and instruction. Kingsley Davis (1951) has also worked out

detailed fertility differentials for different categories of populations from cities and rural areas. Chandrasekharan and George (1962) found marked fertility differentials in three areas of West Bengal, two of which, Ballygunge and Beniatola, were from the city of Calcutta and the third area was from rural Singur in the district of Hooghly. The average number of children per married women aged 45-49 years is 5.7 in Ballygunge, 6.2 in Beniatola and 7.3 in Singur. They are of opinion that the differentials have existed for at least two decades and are due to limitation of pregnancies. The study reveals that fertility has begun to fall long before the present expansion of family planning programmes. Raymond Pearl showed after a detailed study of the American Whites and Negroes that there is no significant difference in innate fertility of the two groups and the differences in fertility were environmental in nature. Criminal abortion, postponement of marriage, involuntary sterility (5.3% ; Lorimer 1958)\* and contraception are the main causes of differential fertility. Pearl (1939) has described eight different variables of fertility and each of these variables is dependent upon a large number of cultural factors, like habits, folkways, religion, education, economic status, etc.

(b) *Sociological*: Frank Lorimer's (1958) study on *Culture and Fertility* has opened a new line of study of the different fertility checks. Culture was so long considered to be irrelevant to fertility, but Lorimer has shown how it is limited in some societies, how some cultures are ambivalent towards it, while how some tend to promote it at a very high level. Its complications due to psychological factors, its variations in the major kinship groups and lastly its variations in the different religions have also been discussed by Lorimer.

In West Bengal, the greatest check in the increase of population, at least among the three upper Hindu castes, has been due to the prohibition of widow remarriage.

Increase of the average age at marriage to 24-25 years in

---

\* Weighted average of 3 Bengali Hindu groups.

the case of high caste Hindu girls is another factor which, according to Lorimer, causes a reduction in fertility level by 25%. Earlier marriage is a desideratum for such girls. Here again is a great problem for the proposed National Commission on Marriage.

(c) *Psychological factors* : Complications due to psychological factors have already been mentioned. In all societies some males are known to show an aversion towards marriage. Goodhart (1956) considers them 'psychologically infecund'. He also states : 'Such infecundity is generally and it is therefore likely to be at least partly conditioned by inherited congenital factors.' This may to some extent be proved from the following pedigree, a large part of which was published elsewhere (Sarkar 1941).

PEDIGREE SHOWING UNMARRIEDS IN TWO GENERATIONS.

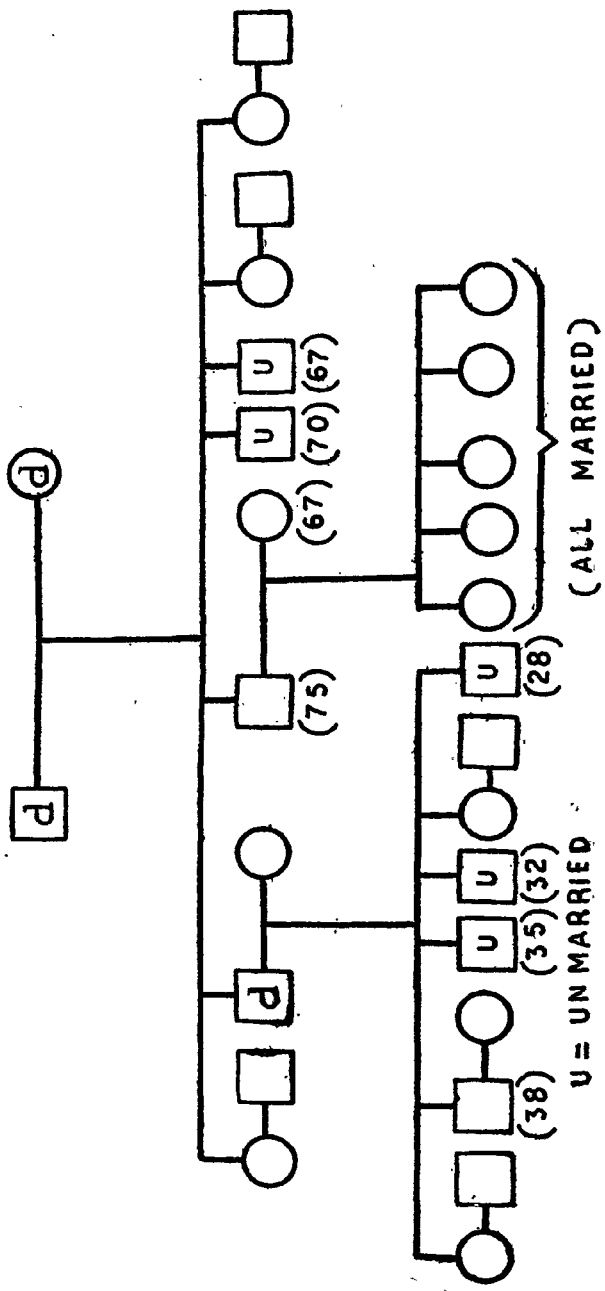

FIG. 10

Asceticism among the Hindus has caused a large number of males remaining celibate. A study of the monks of the various religious organizations like the Ramakrishna Mission, Bharat Sevashram Sangha, Gaudiya Math, etc. will reveal not only the actual frequency of such celibates but also the extent of the psychological infecundity. Stycos (Hardin 1963) in a valuable study has also discussed certain psychological factors such as, *Dominance of Feminism, Indifference, Ambivalence*, etc. which our Indian planners should seriously note along with his references to the speeches of Nehru and Radhakrishnan on family planning.

### *The Problem*

I have tried to show that there is no population problem over which there has been so much hue and cry. Much of it is politically designed. But I never mean that we have no problem. We should have as early as possible a National Commission on Marriage, which must take up the marriage problems of the country. The three urban upper castes of Bengal, among whom the average age at marriage of girls will be about 25 years require immediate attention of our leaders and the parents of the prospective husbands as well. We are all swept away by the mere rate of increase of 2% per annum, but this is not true of all populations. The best example is that of the Parsis of India so thoroughly studied by Chandrasekharan (1948). Nature cannot be so uniform as to be governed by 2% per annum only. Population forecasts are not always reliable. The U. S. A. population of today should have been that of 1985 and that was the forecast of the re-discoverer of the Logistic curve. And that has not thrown the U. S. A. out of gear. On the other hand, they must be enjoying the population pressure and attempting to channelize the surplus growth—if it could really be said so. If it helps the nation, it must also help the family. Stycos is right in saying : 'A large population.....is probably a necessary condition of power. Giant armies and industries both require large population bases, and the total national product of a nation is greatly influenced by the sheer weight of numbers.' The power

sense is equally applicable in peasant and poorer families. 'The population crisis is only the external aspect of what is really a crisis in the family as an institution' (Myrdal 1945). In the words of Mahatma Gandhi, let us have the 'stimulus' of population pressure. And let there be no politics in regard to questions of population.

#### REFERENCES

- Bottiger, L. E., Nordenstam, H. H., and Wester, P. O. 1962. Disseminated Tuberculosis as a cause of fever of obscure origin, *Lancet*, 6 January, 19.
- Chandrasekharan, C. and George, M. V. 1962. Mechanisms underlying the differences in Fertility patterns of Bengalee Women from three Socio-economic Groups, *Milbank Mem. Fund Quart.*, XL, 59-89.
- Chandrasekharan, C. 1948. Some Aspects of Parsi Demography, *Hum. Biol.* 20.
- Das, A. K. and Banerjee, S. K. 1962. Impact of Industrialization on the Life of the Tribals of West Bengal. *Bull. Cul. Res. Inst.*, Special Series No. 1.
- Davis, Kingsley, 1951. *Population of India and Pakistan*.
- Goodhart, C. B. 1966. World Population Growth and its Regulation by Natural Means, *Nature*, 178, 561-565.
- Hardin, Garrett, 1963. *Population, Evolution, Birth Control*, San Francisco.
- 1964. Ultimate Failure of Rhythm, *Science*, 143, 995.
- Lorimer, F. 1958. *Culture and Human Fertility*, Unesco, Paris.
- Lorimer, F. 1967. The Population of Africa. In *The Population of the World*, Madras.
- Mauldin, W. P. 1967. The Population of India. In *The Population of the World*, Madras.
- Pearl, Raymond, 1939. *The Natural History of Population*, London.
- S. S. Sarkar, 1941. *Aims and Objects of Eugenic Researches in India*, Calcutta.



# ANTHROPOMETRY AMONG THE PEOPLES OF MIDNAPUR, WEST BENGAL

PAPIA BANERJEE

( Received on 11 November 1968 )

**Abstract :** An attempt has been made in the present study to utilize the two cranial collections from Contai, Midnapur, West Bengal, and the somatic measurements of the peoples of the same area to find out the physical type of the peoples of the above mentioned area. Furthermore the living measurements of the present investigation have been compared with those of Risley (1891) and Majumdar (1958) collected from Midnapur.

**S**INCE the publication of Myers (1905) the utilization of measurements from the living subjects as well as from the skeletal remains of the same population has been recognized as one of the best approach for the understanding of ethnic bearing of a particular population. In that approach somatometry, craniometry and osteometry come to aid each other in the solution of a common problem. In India such an attempt appears to be rare although Charles (1893) attempted a comparison of the living and the skeletal measurements among the Churas of the Punjab ; the living data utilized were those of Risley (1891).

In consideration of the above-mentioned facts an attempt has been made by the present writer to utilize the two cranial collections from Contai, Midnapur and the somatic measurements of peoples of the same area to find out the physical type of the peoples of the above mentioned area.

## *Material and Method*

The two collections of skulls, the first one being the victim of a cyclonic storm of 1942 (Bhattacharjee 1957) while the second one collected during October, 1959 from the local

---

The author is Pool Officer, CSIR and is attached to the Department of Anthropology, University of Calcutta, Calcutta-19.

cemetery of Khargachandi situated at the outskirts of Contai town, were utilized for the present purpose. During the time of second collection and also in the previous winter (1958) an anthropometric survey was undertaken round the area where from the cranial material was collected.

The total number of individuals measured for the present investigation comprised 504 adults (male, 272; female, 232) while cranial material comprised 68 adult males and 40 adult females. Measurements were taken according to the standard anthropometric technique (Martin 1928). During the later survey (1959) mentioned above the auricular height measurement was repeated with the help of Schultz's Parallelometer which was not available during the survey of 1958. This measurement was repeated when the same person was available. The rest of the data on auricular height were collected anew along with head length and head breadth measurements. This has caused an increase of the cephalic data over other measurements (Table 1).

Furthermore the living measurements of the present investigation were compared with those of Risley (1891) and Majumdar (1958) collected from Midnapur, West Bengal. The two sets of data thus comprised 41 individuals from Risley (1891) and 97 individuals (excluding Mahato and Muslims) from Majumdar (1958). For the sake of brevity the three samples have been abbreviated as follows: Risley's male sample—R; Majumdar's male sample—M; the present male sample C/M and the female sample—C/F.

The statistical constants of the living measurements and indices of Contai males and females have been presented in the Table 1 while mean values of R, M and C/M along with the values of 't' in between the three sets of data have been presented in the Table 2. As the cephalic and cranial linear measurements are not comparable to each other due to the presence of soft tissues and skin on the former, only the percentage occurrences of indices have been considered in the present study. The correlative study on cephalic and cranial linear measurements of the same population have already been reported (Banerjee 1968).



Character	Female				
	No.	Range	Mean $\pm$ S. E.	S. D.	C. V.
Head height	102	107- 132	117.85 $\pm$ 0.42	4.20	3.56
Min. frontal breadth	190	89- 110	99.78 $\pm$ 0.31	4.26	4.27
Bizygomatic breadth	190	108- 136	124.17 $\pm$ 0.35	4.86	3.91
Total facial height	189	94- 121	106.42 $\pm$ 0.40	5.52	5.09
Upper facial height	189	49- 73	61.10 $\pm$ 0.34	4.66	7.63
Nasal height	190	39- 58	46.82 $\pm$ 0.24	3.26	6.96
Nasal breadth index	190	27- 39	32.56 $\pm$ 0.16	2.24	6.88
Length-breadth index	232	69.49-91.02	79.09 $\pm$ 0.27	4.18	5.28
Length-height index	102	60.11-75.15	68.41 $\pm$ 0.30	3.00	4.39
Breadth-height index	102	79.02-96.12	87.15 $\pm$ 0.37	3.74	4.29
Jugo-frontal index	190	74.02-90.18	80.41 $\pm$ 0.22	2.98	3.71
Transverse fronto- parietal index	190	64.67-80.00	72.31 $\pm$ 0.20	2.82	3.90
Total facial index	189	74.26-96.61	85.75 $\pm$ 0.33	4.54	5.29
Upper facial index	189	39.55-60.00	49.13 $\pm$ 0.29	3.96	8.06
Nasal index	190	56.86-88.64	69.81 $\pm$ 0.47	6.42	9.20

TABLE 2

*Values of 't' between R, M and C/M along with the mean values.*

Character	Mean $\pm$ S. E.			Values of 't'		
	R	M	C/M	R & C/M	M & C/M	R & M
Weight	105.92 $\pm$ 1.66	104.70 $\pm$ 1.44	105.75 $\pm$ 0.84	0.09	0.06	0.55
Stature	1625.10 $\pm$ 8.07	1655.20 $\pm$ 6.82	1634.90 $\pm$ 4.27	1.01	2.52	2.78
Head length	181.58 $\pm$ 1.14	185.38 $\pm$ 0.69	183.04 $\pm$ 0.44	1.19	2.85	2.85
Head breadth	141.48 $\pm$ 0.71	137.70 $\pm$ 0.56	143.16 $\pm$ 0.34	2.13	8.40	4.20
Min. frontal breadth	102.30 $\pm$ 0.61	101.76 $\pm$ 0.40	102.44 $\pm$ 0.35	0.20	1.28	0.74
Bizygomatic breadth	128.84 $\pm$ 0.81	129.39 $\pm$ 0.50	131.67 $\pm$ 0.36	3.21	3.74	0.57

Character	R	Mean + S. E.			Values of 't'		
		M	C/M		R & C/M	M & C/M	R & M
Total facial height	-	107.46 ± 0.66	113.92 ± 0.41	-	8.39	-	-
Upper facial height	-	58.94 ± 0.51	66.52 ± 0.29	-	13.06	-	-
Nasal height	48.28 ± 0.54	47.68 ± 0.41	50.86 ± 0.24	3.52	5.70	0.88	
Nasal breadth	36.62 ± 0.47	36.28 ± 0.26	35.35 ± 0.20	2.49	2.90	0.63	
<i>Indices</i>							
Length-breadth	77.85 ± 0.58	74.83 ± 0.41	78.27 ± 0.25	0.67	8.21	4.95	
Jugo-frontal	79.39 ± 0.53	78.27 ± 0.22	77.79 ± 0.20	2.86	1.60	1.96	
Total facial	-	83.22 ± 0.53	87.53 ± 0.33	-	7.06	-	
Upper facial	-	45.41 ± 0.41	50.59 ± 0.24	-	11.02	-	
Nasal	76.85 ± 1.44	76.40 ± 0.74	70.38 ± 0.49	4.25	6.84	0.28	

## Result and Discussion

### Weight

It will be apparent from the Table 2 that weight of the peoples of Midnapur has not changed, almost at all, since Risley's time and this is confirmed by the mean values of M and C/M. No significant difference has been found between the mean weight found by Risley and the mean of Majumdar as well as the mean of the present sample.

### Stature

In respect of stature M shows the highest mean of the three male samples compared here and differs significantly from R and C/M. The difference between the latter two samples (R & C/M) is not statistically significant. The percentage occurrences of different forms of stature have been presented in Table 3 and it will be seen therefrom that short to below medium stature occurs in the highest frequency among the peoples of Midnapur.

TABLE 3

*Percentage occurrence of stature.*

Character	R	M	C/M	C/F
Very short	2.4	4.1	2.3	5.8
Short	24.4	30.9	26.5	44.2
Below medium	39.0	24.7	25.6	24.2
Medium	19.5	10.3	17.7	15.8
Above medium	2.4	14.4	15.8	4.7
Tall	12.2	14.4	12.1	5.3
Very tall	-	1.0	-	-
<b>Head form</b>				

In head length M shows the highest mean and differs significantly from R and C/M while the latter two do not differ significantly. The above agreement between R and C/M is also borne out by the mean values of head breadth. In head breadth M shows the lowest mean value and the differences between M and R and between M and C/M are highly significant while the difference between R and C/M is on the border line of significance.

The measurement on head height appears to be very variable due to the difference in the technique of measurement and as such it has not been compared here. The horizontal circumference of head was not measured by the other two authors. Contai females were also not measured for horizontal circumference of head due to their thick long hair.

In length-breadth index there is a close similarity between R and C/M while M shows the lowest mean and differ significantly from the former two. The differences in the mean values are also reflected in the percentage occurrences of the different head forms (Table 4). In this respect cranial data also show a different picture from M and stand in close agreement with R and C/M.

TABLE 4

*Percentage occurrence of length-breadth index.*

Character	R	M	C/M		C/F	
			Living	Skull	Living	Skull
Hyperdolichocephaly		15.5	2.6	10.2	1.3	2.9
Dolichocephaly	34.2	51.6	29.0	33.9	23.3	11.8
Mesocephaly	46.3	26.8	42.7	39.0	44.4	64.7
Brachycephaly	17.1	5.1	21.0	15.3	23.7	14.7
Hyperbrachycephaly	2.4	1.0	4.8	1.7	7.3	5.9

Head form of the Contai males and females, both living and skull, and also that of R appears to be mainly mesocephalic while M shows mainly the dolichocephalic form.

In length-height index and breadth-height index Contai males and females, both living and skull, show mainly hypsicephalic (Table 5) and acrocephalic (Table 6) forms respectively.

TABLE 5

*Percentage occurrence of length-height index.*

Character	C/M		C/F	
	Living	Skull	Living	Skull
Chamaecephaly	—	1.7	—	—
Orthocephaly	5.8	8.5	5.5	8.8
Hypsicephaly	94.2	89.8	94.5	91.2

TABLE 6

*Percentage occurrence of breadth-height index.*

Character	C/M		C/F	
	Living	Skull	Living	Skull
Tapeinocephaly	1.0	1.7	—	2.9
Metriocephaly	27.9	27.1	31.4	41.2
Acrocephaly	71.1	71.2	68.6	55.9

**Facial form**

C/M differs from M significantly in total facial height and upper facial height and also in the two facial indices. The differences in the mean values of upper facial index and total facial index are also reflected in the percentage occurrences of different facial forms (Tables 7 & 8).

TABLE 7

*Percentage occurrence of total facial index*

Character	M	C/M	C/F
Hypereuryprosopic	17.5	1.9	6.4
Euryprosopic	37.1	21.1	30.7
Mesoprosopic	24.7	32.4	33.3
Leptoprosopic	19.6	24.9	20.6
Hyperleptoprosopic	1.0	19.7	9.0

In total facial form C/M and C/F show mainly mesoprosopic form while M shows mainly euryprosopic type.

TABLE 8

*Percentage occurrence of upper facial index.*

Character	M	C/M		C/F	
		Living	Skull	Living	Skull
Hypereuryene	25.8	1.4	3.7	4.2	3.3
Euryene	46.4	19.3	29.6	35.5	16.7
Mesene	26.8	59.2	61.1	44.4	60.0
Leptene	1.0	16.0	5.6	11.6	20.0
Hyperleptene	—	4.2	—	4.2	—



In upper facial index Contai males and females, both living and skull, show mesene form of face in the highest frequency while M shows euryene face in the highest frequency.

Risley however did not take the above two facial measurements.

The mean values of minimum frontal breadth of R and C/M are very close to one another while M shows the lowest value, the differences however are not statistically significant.

#### Nasal form

The significant difference in nasal height between R and C/M may be due to the use of a different landmark for nasion (sellion) by Risley. In nasal breadth and nasal index C/M shows the lowest mean and differs significantly from R and M.

In nasal form all the three living groups are however appear to be mainly mesorrhine (Table 9) while male and female crania show chamaerrhine in the highest frequencies. It has already been shown by Charles (1894) and Schultz (1918) and others that the nasal measurements are not comparable in the living and skull, and as such these have not been compared here.

TABLE 9

*Percentage occurrence of nasal index.*

Character	R	M	C/M	C/F
Leptorrhine	22.0	18.6	46.3	50.5
Mesorrhine	65.9	71.1	51.4	47.9
Chamaerrhine	7.3	10.3	2.3	1.6
Hyperchamaerrhine	4.9	-	-	-

It will be apparent from the above presentation that when compared with Risley's and Majumdar's samples, Contai males appear to be closer to Risley's mean values than those of

Majumdar in the majority of characters. Majumdar's mean values appear to be extreme in nature. In stature and head length Majumdar's means are the highest of the three samples compared here while in head breadth, minimum frontal breadth and nasal height Majumdar's means appear to be the lowest of all. In bizygomatic breadth and nasal breadth the mean values of Majumdar's sample however occupy an intermediate position. It has already been pointed out (Banerjee 1960) that the measurements of head which are known to vary lesser than the other characters, show the largest variation particularly when Majumdar's sample is taken into account. In the present study in head length M shows the highest mean but in the case of head breadth the lowest one and these two measurements of Majumdar's sample differ significantly from those of R and C/M.

Compared with it, the constancy of weight in the three samples is rather surprising. M shows the lowest mean weight of 104.70 lbs. compared to 105.92 lbs. (converted from gram) of R and 105.75 lbs. of C/M.

It is worth while pointing out that in head shape Risley's sample, Contai males and females, both living and skull, appears to be similar to each other while Majumdar's sample stands wide apart in this respect. In facial form also Majumdar's sample shows a different picture than C/M and C/F, both living and skull.

Summing up, it has been found that peoples of Midnapur are mainly short to medium in stature. Head form is mainly mesoprosopic, hypsiccephalic and acrocephalic. Cranial data of the present study also agree well in this respect. In facial form, they appear to be mainly mesoprosopic and mesene. In the latter character (upper facial form) cranial data also appear to give an additional support to the above finding. In nasal form the living population appear to be mainly mesorrhine while in cranial data chamaerrhine appear to be predominant type.

Thanks are due to Dr. S. S. Sarkar for his kind advice for the work.

## REFERENCES

- Banerjee, P. 1960 : A comparative study of the Oraon physical characters. *Bull. Dept. Anthro. Govt. Ind.* 9 : 89-100.
- 1968 : Cephalic and cranial correlations. *Man in India.* 48 : 264-274.
- Bhattacharjee, P. 1957 : Cranial capacity of Bengalee Skulls. *Man in India*, 37.
- Charles, H. 1893 : Contributions to the craniology and craniometry of the Panjab tribes. *J. Anat. and Physiol.* 27 : 5.
- Majumdar, D. N. and Rao, C. R. 1958 : Bengal anthropometry survey, 1945. A statistical study. *Shankhya*, 19 pt. 3 and 4
- Martin, R. 1928 : *Lehrbuch der Anthropologie.* Ban. 1. *Jena.*
- Myers, S. 1905 : Contributions to Egyptian Anthropometry II. The comparative anthropometry of most and modern inhabitants. *J. Roy. Anth. Inst.*, 35 : 80-91.
- Risley, H. H. 1891 : Tribes and castes of Bengal. *Data.* Vol. 1. *Calcutta.*
- Schultz, A. H. 1918 : Relation of the external nose to the bonny nose and nasal cartilage in Whites and Negroes. *Am. J. Phy. Anth.*, 1 : 329-338.

# ABO BLOOD GROUP FREQUENCIES OF INDIA, PAKISTAN AND THE ADJOINING AREAS AS A WHOLE

ALOKE KUMAR GHOSH

**Abstract:** Following McArthur and Penrose's world average for ABO-blood groups, an average for India, Pakistan, Ceylon, Nepal and Maldivé Islands has been calculated on the basis of almost all data published up to 1965. The data have been divided into two groups, Australoids and the 'Rest'. The data have been tested for Penrose's formula for genetic distance.

**T**HE present study is an attempt to find out an average for ABO blood groups for India, Pakistan, Bhutan, Nepal, Ceylon and the Maldivé Islands as a whole. McArthur and Penrose (1949) calculated average world frequencies of the ABO blood group genes, in which all the gene frequencies of the different countries of the world were taken into consideration. For the average gene frequencies for India, Bhutan, Ceylon, Maldivé Islands, Nepal and Pakistan, they were able to utilize ABO blood groups data upto 1949. Since 1949 a considerable amount of work on ABO blood groups has been done in India and the adjoining countries. As such in the present study all data upto 1965 have been collected together to find out the average ABO gene frequencies as a whole for the above contiguous geographical area. All published data on ABO blood groups have been taken into account, though a few samples might have escaped our attention. The utility of such an average, not only for blood groups, but also for all anthropometric characters, lies in the rating of any population, as shown by Penrose (1955). According to him, "Any population can be rated according to its divergences from these standard frequencies by summing the squares of the differences between standard values and those in the specific population."

---

The author is attached to the Department of Anthropology, University of Calcutta, 35 Bellygunge Circular Road, Calcutta—19.

### Method

All published ABO blood group data of the above-mentioned countries have been collected. Some of the data have been excluded for doubtful percentile frequencies. In some cases absolute numbers were not available, and they were calculated from the given percentile frequencies. Then the whole data for the above mentioned countries were pooled together, and the percentages of O, A, B and AB calculated. Gene frequencies were estimated according to Bernstein's improved formulae.

Table 1 shows the absolute numbers of the four blood groups, their percentages and gene frequencies for India, Bhutan, Ceylon, the Maldiv Islands, Nepal, and Pakistan.  $D/\sigma$  is 6 and  $\text{Chi}^2$  is 6.3218, which indicate that the probability is less than 2% for 1 D. F. The pooled data are thus heterogeneous in nature. This is expected since peoples of various ethnic strains and mating groups have been pooled together. The two series of Table 1 express a good deal of similarity between them. But compared with world frequencies (McArthur and Penrose 1949) the average  $q$  (.226) for the above five countries is much greater than the world average of .162, while the values of  $p$  (.184) and  $r$  (.591) are less in the former than the world averages of .215 and .623 respectively. The Australoid populations of India have been pooled together and separately shown. Its values of  $p$ ,  $q$  and  $t$  .206, .175 and .611 respectively. Compared with the Rest (Table 1) it is seen that  $p$  and  $r$  are greater but  $q$  is lesser among Australoids than those in the 'Rest.' The Australoid sample is also highly heterogeneous ( $\text{chi}^2 = 14.7385$ ) while that of the Rest shows considerable homogeneity. This statistical homogeneity is not, however, borne out by anthropological studies. The genetical distance ( $D^2$ ) calculated according to Penrose (1966), in respect of this character, between the world average and the average of the present study is .006144. Between the Australoid and the Rest it is .004281. The  $D^2$  values show that the genetic distance between the world frequencies and those of the present study is greater than that between the Australoid and the Rest.

TABLE I  
*ABO Blood and their frequencies*

Author	Population	Total	O	A	B	AB	P	q	r	x <sup>2</sup>
Present Study	Anstratoids	5347	2004	1645	1374	824	0.2060	0.1747	0.6193	14.7885
	Rest	134588	46664	33575	43293	11056	0.1825	0.2280	0.5895	2.8588
	India, Bhutan, Ceylon, Maldive Islands, Nepal and Pakistan	139935	48668	35220	44667	11380	0.1834	0.2258	0.5908	6.3218
McArthur and Penrose	India, Bhutan, Ceylon, Maldive Islands and Pakistan		34.78%	25.17%	31.92%	8.18%	0.185	0.230	0.585	
do	World Average						0.215	0.162	0.623	

## REFERENCES

- Basu, A., Sarkar, J., Roy, B., Dasgupta, P., Sanyal, A., and Sarkar, S. S. (1966). Anthropo genetic investigation in the Dalma and the Ajodhya Hills and their neighbourhood. *Sci. and Cult.*, 32, 273-275.
- Bhattacharjee, P. (1957). A genetic survey in the Rarhi Brahmins and Muslims of West Bengal :  $A_1-A_2-B-O, M-N, Rh$ -blood groups, ABH secretion, sickle-cell, P. T. C. taste, Midphalangeal hair and colour blindness. *Bull. Dept. Anth.*, V, 18-28.
- Bird, G. W. G., Elizabeth, W. Ikin, Mourant, A. E. and Lehmann, H. (1962). The Blood groups and Haemoglobin of the Malayalis. 'Indian Anthropology' edited by T. N. Madan and G. Saran, Bombay, 221-226.
- Bird, G. W. G., Krishnaswami, P. and Menan, K. K. (1964).  $A_1-A_2-BO$  blood groups of Marathas (Kshatriyas). *Man*, 64 : 19.
- Biswas, K. C. (1955). Blood groups from Cooch-Bihar. *Sci. and Cult.* 21 : 256.
- Boyd, W. C. (1939). Blood groups. *Tabul. Biol.*, 17 : 113-240.
- Chakravorty, M. (1965). A note on ABO blood groups of the Thadou Kuki of Nagaland. *Sci. and Cult.* 31 : 264.
- Chakravorty, M. (1965). ABO blood groups of the Zeliang Nagas. *Man in India.* 45 : 311-315.
- Das, B. M., Agarwal, K. K., Gupta, P., Banerjee A., Bose, A., and Mukherjee, B. (1953). Blood groups from Calcutta. *Sci. and Cult.* 19 : 164.
- Das, S. R. and Sastry, D. B. (1960). Simplified maximum likelihood estimation of the A-B-O gene frequencies : Results for a few Indian peoples surveyed. *Bull. Anth. Surv. India.* IX : 1-8.
- Das, S. R., Kumar, N., Bhattacharjee, P. N. and Sastry, D. B. (1961). Blood groups (ABO, MN and Rh), ABH secretion, sickle-cell, P. T. C. taste and colour-blindness in the Mahar of Nagpur. *J. Roy. Anth. Inst.* 91, 2 : 345-355.
- Dronamraju, K. R., Meera Khan, P. and Narayana Murty, V. V. (196). ABO blood groups of the Andhras, *Man*, 62 : 71.
- Ghosh, A. K. (1964). ABO blood groups from Singbhum, Bihar. *Sci. and Cult.*, 30 : 49-50.
- Ghosh, A. K. (1962). ABO blood groups of Santal (unpublished).
- Ghosh, L. (1962). ABO, MN blood groups and secretor factor in the Padmaraj of West Bengal. *Z. Morph. U. Anth.* 52 : 290-294
- Gershowitz, H. (1959). The Diego factor among Asiatic Indians, Apaches and West African Negroes : Blood types of Asiatic Indians and Apaches. *Amer. J. Phys. Anth.*, 17 : 195-200.

- Kirk, R. L., Lai, L. Y. C., Vos, G. H., Wickremasinghe, R. L. and Perers, D. J. B. (1962). The blood and serum groups of selected populations in South India and Ceylon. *Amer. J. Phys. Anth.*, 20 : 485-497.
- Kirk, R. L., Lai, L. Y. C., Vos, G. H. and Vidyarthi, L. P. (1962). A genetical study of the Oraons of the Chota Nagpur Plateau (Bihar, India), *Amer. J. Phys. Anth.* 20 : 375-385.
- Kumar, N. (1957). A genetic survey among the Tentulia Bagdi and Duley of Hooghly district in West Bengal, *Bull. Dept. Anth.*, VI : 81-88.
- Kumar, N. ABO blood groups and sickle-cell trait investigation in Madhya Pradesh, Indore District. *Acta. Genet. Med. Gemellol.* (in press).
- Kumar, N. (1965). ABO blood groups and sickle-cell trait investigations in Madhya Pradesh ; Ratlam and the adjacent districts. *Bull. Anth. Surv. India.* 14 (3 & 4).
- Kumar, N. and Sastry, D. B. (1961). A genetic survey among the Riang : A mongoloid tribe of Tripura. *Z. Morph. Anth.* 51 : 346-356.
- Kumar, N. and Ghosh, A. K. (1967). ABO blood groups and sickle-cell trait investigations in Madhya Pradesh ; Ujjain and Dewas districts. *Acta Genet. (Basel)*, 17 : 55-61.
- Majumdar, D. N. (1942). Blood groups of the Bhils of Gujarat. *Cur. Sci.*, XI : 353-354.
- Majumdar, D. N. (1942). The Tharus and their blood groups. *J. R. A. Soc. Beng.* VIII : 25-27.
- Majumdar, D. N. (1940). Blood groups and their distribution in certain castes in the United Provinces. *Sci. and Cult.*, 5 : 519-522.
- Majumdar, D. N. and Rao, C. R. (1960). Race Elements in Bengal, Calcutta.
- McArthur, N. and Penrose, L. S. (1949). World frequencies of the O, A and B blood group genes. *Ann. Eug.*, 15 : 302-305.
- \*Mourant, A. E. (1962). Notes on blood groups in India, *India Anthropology*, edited by T. N. Madan and G. Saran. Bombay, 185-192.
- Mourant, A. E., Kopec, A. C. and Domaniewska-Sobezak, K. (1958). The ABO blood groups. Oxford.
- Pathak, U. (1959). Incidence of Rh in the Punjabi females. *J. Ind. Med. Ass.*, 33 : 213-216.
- Penrose, L. S. (1955). Genetics of Human Races. *Genetics in 20th Century* New York.
- Penrose, L. S. Personal communication to Dr. S; S. Sarkar, dated 19. 10 66.
- Roy, P. (1962). ABO blood groups from Nazat, 24-Parganas, West Bengal. *Sci. and Cult.*, 28 : 243-244.



- Sarkar, S. S. (1940). Blood groups of the Angami Nagas. *Nature*, 145 : 261.
- Sarkar, S. S., Banerjee, A. R., Bhattacharjee, P. and Roy, A. K. (1960). Further studies on ABO blood groups from Orissa. *Sci. and Culti.*, 25 : 694-695.
- Singh, I. P. and Singh, D. (1961). The study of ABO blood groups of Sainis of Punjab. *Amer. J. Phys. Anth.*, 19 : 223-225.
- Srivastava, R. P. (1965). Blood groups in Tharus of Uttar Pradesh and their bearing on ethnic and genetic relationships. *Hum. Biol.* 37 : 1-12.
- Vyas, G. N., Bhatia, H. M., Sukumaran, P. K. Balakrishnan, V. and Sanghvi, L. D. (1962) Study of blood groups, Abnormal haemoglobins and other genetical characters in some tribes of Gujarat. *Amer. J. Phys. Anth.*, 20 : 255-265.
- Wickremasinghe, R. L., Elizabeth, W., Ikin, Mourant, A. E. and Lehmann, H. (1963). The blood groups and haemoglobins of the Veddahs of Ceylon. *J. Roy. Anth. Inst.*, 93 : 117-125.

---

\*For further details, see its bibliography.

# A STUDY OF FINGER BALL DERMATOGLYPHICS IN WEST BENGAL

DHARMADAS SARKAR

(*Received on 1 December, 1968*)

**Abstract :** In the present paper the author has made an attempt to find out the pattern type variabilities among the six endogamous groups, namely, Brahmin, Kayastha, Namasudra, Rajbanshi, Muslim and Rabha (female) of Jalpaiguri District, West Bengal. The analysis includes the examination of the individual and comparative distribution of the principal patterns, both, hand-wise and digitwise, and their relevant indices.

## *Introduction*

THE purpose of the present paper is to study the extent of variability of the dermal ridge configurations existing in each of the six population groups, namely, Brahmin, Kayastha, Namasudra, Rajbanshi, Muslim and Rabha (female) of the Jalpaiguri District of West Bengal, and to reconcile their biological relationships, if any. The Brahmin and the Kayastha are traditionally held as belonging to the upper castes, while the Namasudra and Rajbanshi as belonging to the lower strata of the Hindu society. The Muslims are considered as a religious community. The Rabhas are a local tribe and linguistically they belong to Bodo group (Sunder's Report of 1895, quoted by Mitra 1954).

According to Risley (1891) the Namasudras are a non-Aryan caste of Bengal engaged for the most part in cultivation. While, the Rajbanshis and Koches of Cooch-Bihar and neighbouring areas have the same origin and described by Risley (1891) as a Dravidian tribe with suspected Mongolian admixture. But they are now recognized as a distinct Hindu caste (Sunder's Report of 1895, quoted by Mitra 1954).

---

The author is attached to the Anthropological Survey of India. His personal address is C/o Anthropological Survey of India, 27 Jawaharlal Nehru Road, Calcutta - 13.

### *Material and Method*

The present paper attempts only in studying the apical dermal configurations. Finger and palmar impressions of 682 individuals belonging to the caste communities and tribal groups were collected by the author during November-February, 1963-64. The samples belong to various localities of the district. Care was taken in selecting unrelated individuals for a sample. Here the samples considered are five male groups and one female group, who belonged to all ages, varying from 7 years to 65 years. The male material consists of prints of Brahmin ( $n=111$ ), Kayastha ( $n=120$ ), Namasudra ( $n=108$ ), Rajbanshi ( $n=145$ ) and Muslim ( $n=114$ ), while the female material comprises only of Rabha ( $n=84$ ), and each of them belongs to an endogamous group. Due to the loss of third phalanges in left digit V of one member of the Kayastha, and left digit II of one member of the Muslim, the total estimable number of finger prints falls short by one print from each of the group.

### *Results and Discussion*

#### **Papillary Patterns**

In Table 1 the digitwise distribution of the papillary pattern frequencies among the six population groups of the Jalpaiguri District has been presented.

(a) *Whorl*: In the distribution of whorl pattern, it is evident that except in one instance the digit IV has recorded the highest incidence of whorl, which is followed by a gradual decreasing trend of gradients in other digits. The frequency of whorl is found to be highest in digit IV, less in I, smaller in II and finally lowest in III and V. This digitwise diminutive trend which holds valid for all the groups excepts Kayastha. In the Kayastha group the distribution of whorl differs in digit I and IV, and in III and V; here the above-said order follows through digit I to IV and V to III, instead of the unidirectional trend shown by the rest.

(b) *Loop ulnar*: For the investigated populations, ulnar loops occur mostly in digits V and III, of which the digit V

displays the highest incidence. Loop ulnar in digits I and II occurs almost in equality among the Rajbanshi and Muslim populations, while the equality in this regard is expressed in digits II and IV of the Kayasthas and Muslims. Leaving aside those two involved digits, (i. e., V and III) the manifestation of ulnar pattern in others is less and variable.

(c) *Loop Radial*: Evidence of radial pattern is more in digit II, and rare in digits IV and V respectively. However, the manifestations of radial design in the latter two digits among the Rajbanshi and Muslims can not be denied. In view of the incidence of higher values and of equality in distribution of the pattern in digit II, the Namasudra and Muslim closely resemble each other.

(d) *Arch*: Arch configuration among the involved populations extends to the highest degree in digit II. Lesser manifestation of the concerned pattern is involved in digit V; and four, of the considered population does not show any existence of the pattern in digit V. The expression of arch, however, mainly follows two decreasing gradients i. e., (i) from digit II>III>I>IV>V, while the other (ii) from digit II>I>III>IV>V. The first course is followed by the Brahmin, Kayastha and Namasudra, while the second course has been taken up by the Rajbanshi, Muslim and Rabha groups. The two gradients, therefore, mainly refer to the interchanging of positions between digits III and I, and vice versa.

In Table 2 distribution of the principal papillary designs and their indices have been illustrated. It is clearly seen from the illustration that all the populations have a higher percentage of loop over the whorl configurations. It is interesting to note that the Rajbanshi (W = 41.52%, L = 56.34%) and Muslims (W = 40.83%, L = 56.80%) closely resemble one another in respect of whorl and loop patterns. The diversification of the Namasudras from the rest of population in regard to whorl and loop pattern (W = 47.04%, L = 51.30%) is well evidenced. However, it is apparent that the varying magnitude in respect of frequency estimates of the principal pattern types does not

exceed beyond five units, excepting the Namasudra whose whorl value ( $W = 47.04\%$ ) exceeded the aforesaid limit. In the distribution of arches, the populations maintain this limital uniformity. Thus, in respect of the different configurational variables in the populations no significant heterogeneity could be observed among them, as the magnitude of the pattern variations is not large enough.

From the examination of different indices, it is clearly evident that the indices of pattern intensity and whorl-loop are relatively higher among the Namasudras (P. I. I. = 14.54, W/L. I. = 91.69). A rise in the whorl-loop, or in the pattern intensity index is due to the subsequent increase of whorl configurations, while the loop plays a delicate role in influencing the indices (Dankmeijer 1938).

### *Handwise indices and frequency distributions of papillary patterns*

Frequency of the main papillary configurations in the individual hands and the indices derived out of them are given in Table 3. It appears from the Table 3 that the right hand always shows a comparatively high occurrence of whorls, but lesser in the manifestation of loops among the populations. Whereas, the Rabha population shows a reverse trend in respect of whorl and loop manifestations. In general the arches occur more in the left hand. Moreover, it is observed that the pattern intensity (Cummins 1943) and whorl loop index (Furuhatta 1927) of the right hand, are comparatively high among majority of the populations. Exceptions is limited to the arch-whorl index (Dankmeijer 1938) which is seen to increase in the left hand.

### *Pattern intensity index and its significance*

To evaluate the quantitative difference in the manifestation of patterns, the mean P. I. I. and its relevant statistical derivatives have been put forward in Table 4. It is evident from the table that P. I. I. ranges from 2.0 to 20.0 for the populations considered. The mean value of P. I. I. is seen

highest among the Namasudra (P. I. I. =  $14.54 \pm 0.30$ ). Moreover, it is interesting to note that the mean P. I. I. of the Kayastha and Namasudra, the Rajbanshi, Muslim and Rabha groups shows almost equal consistency. While, the Brahmins are found to be more variable in this respect, having the lowest mean of  $13.23 \pm 0.37$  with a standard deviation  $3.93 \pm 0.26$ . The index of finger pattern intensity is claimed to be one of the most important ethnic determinants in the study of dermatoglyphics (Newman 1960). Thus, here an attempt has been made to evaluate the biological relationship of the considered populations of Jalpaiguri District in view of the above index. Apparently it is observed that there exists inter-group difference in P. I. I. ; but when it is statistically treated, gives no significant results at 5% level of probability (Table 5), excepting the Brahmin versus Namasudra which gives a highly significant result ( $0.010 > P > 0.005$ ).

### *Summary*

A study relating to the finger ball pattern variability among the Brahmin, Kayastha, Namasudra, Rajbanshi, Muslim and Rabha populations of Jalpaiguri District, West Bengal has been made. In terms of the Hindu social order, these populations occupy different positions in the hierarchy. The position of Brahmin is highest, next comes the Kayastha, while the Namasudra occupy the lowest position. The Muslims whom we have considered from a religious community.

The Rajbanshis are now a distinct caste of the Hindus having affinity with the Koches of Mongoloid admixture. The Rabhas are a tribal group linguistically affiliated to the 'Bodos.'

In the manifestation of principal papillary configuration and in pattern intensity index, no significant variation has been found among the populations. In pattern intensity index between the Brahmin and Namasudra ; variation is however found to be highly significant. The Rajbanshi and Muslims closely resemble each other in the incidences of whorl and loop pattern, and in pattern intensity index.

## ACKNOWLEDGEMENT

The author expresses his indebtedness to Dr. D. K. Sen, Director, Anthropological Survey of India, for providing necessary facilities for the study.

## REFERENCES

- Cummins, H. and Midlo, C. 1943 : *Finger Prints, Palms and Soles. An Introduction to Dermatoglyphics.* The Blakiston Co. Philadelphia.
- Dankmeijer, J. 1938 : Some anthropological data on finger prints. *Am. J. Phy. Anthropol.*, 23, 377-388.
- Newman, M. T. 1960 : Populational Analysis of Finger and Palms Prints in Highland and Lowland Maya Indians. *Am. Jr. Phy. Anthropol.* N. S: 18, 45-58.
- Holt, S. B. 1961 : Inheritance of dermal ridge patterns. In *(Recent Advances in Human genetics, Edited by L. S. Penrose. J. and A. Churchill Ltd., London, 101-119.*
- Mitra, A. 1953 : *The Tribes and castes of West Bengal, Census 1951 West Bengal* P. 73, 75, 76.
- Mitra, A. 1954 : *District Hand Book Jalpaiguri, Census 1951, West Bengal.* Appendix IV. P, C1v and C1xv.
- Risely, H. S. I. 1891 : *Tribes and Castes of Bengal,* Vols. 1 and 2.

TABLE 1a

*Digitwise distribution of papillary patterns (Brahmin. Male. Jalpaiguri)*

Patterns	Digits (R + L, combined)					Remarks
	I	II	III	IV	V	
	(N=222)%	(N=222)%	(N=222)%	(N=222)%	(N=222)%	
Whorl	47.30	36.94	27.48	56.31	23.42	
Loop, U	46.85	43.69	63.96	40.09	75.68	
Loop, R	0.45	7.21	0.90	0.0	0.0	
Arch	5.40	12.16	7.66	3.60	0.90	

TABLE 1b

*Digitwise distribution of papillary patterns (Kayastha, Male, Jalpaiguri)*

Patterns	Digits (R+L combined)					Remarks
	I (N=240)%	II (N=240)%	III (N=240)%	IV (N=240)%	V (N=239)%	
Whorl	59.17	41.67	26.67	56.25	28.03	*One finger
Loop, U	40.0	43.33	70.42	42.92	71.97	tip in L, V
Loop, R	0.0	10.83	0.83	0.0	0.0	is absent
Arch	0.83	4.17	2.08	0.83	0.0	

TABLE 1c

*Digitwise distribution of papillary patterns (Namasudra, Male, Jalpaiguri)*

Patterns	Digits (R+L combined)					Remarks
	I (N=216)%	II (N=216)%	III (N=216)%	IV (N=216)%	V (N=216)%	
Whorl	59.26	45.83	30.56	68.98	30.55	
Loop, U	39.81	35.18	66.67	30.55	69.44	
Loop, R	0.46	14.35	0.0	0.0	0.0	
Arch	0.46	4.63	2.78	0.46	0.0	

TABLE 1d

*Digitwise distribution of papillary patterns (Rajbanshi, Male, Jalpaiguri)*

Patterns	Digits (R+L combined)					Remarks
	I (N=290)%	II (N=290)%	III (N=290)%	IV (N=290)%	V (N=290)%	
Whorl	50.69	40.34	31.37	60.34	24.83	
Loop, U	45.52	46.90	65.17	38.96	74.13	
Loop, R	0.34	9.31	1.03	0.0	0.34	
Arch	3.45	3.45	2.41	0.69	0.69	



TABLE 1e

*Digitwise distribution of papillary patterns (Muslim, Male, Jalpaiguri)*

Patterns	Digits (R+L, combined)					Remarks
	I (N=228)%	II (N=227)%	III (N=228)%	IV (N=228)%	V (N=228)%	
Whorl	56.58	37.88	26.75	57.02	25.88	*One finger tip
Loop, U	40.35	41.85	69.74	41.67	74.12	is absent in
Loop, R	0.0	14.10	0.88	1.31	0.0	L, II
Arch	3.07	6.17	2.63	0.0	0.0	

TABLE 1f

*Digitwise distribution of papillary patterns (Rabha, Female, Jalpaiguri)*

Patterns	Digits (R+L, combined)					Remarks
	I (N=168)%	II (N=168)%	III (N=168)%	IV (N=168)%	V (N=168)%	
Whorl	52.38	39.88	34.52	63.69	20.83	
Loop, U	41.67	47.02	61.31	34.52	79.17	
Loop, R	0.0	5.95	1.19	0.0	0.0	
Arch	5.95	7.14	2.98	1.78	0.0	

TABLE 2

*Comparative distribution of principal pattern types and their indices among the population groups.*

Population group	Sex	Pattern types				Indices			
		Whorl %	Loop % U R	Total %	Arch %	P.I.I.	Ar/W.I.	W/L.I.	
Brahmin (N=111)	M	38.29	54.04	1.71	55.77	5.95	13.23	15.53	68.65
Kayastha (N=120)	M	42.37	53.71	2.33	56.05	1.58	14.07	3.78	75.59
Namasudra (N=108)	M	47.04	48.33	2.96	51.30	1.67	14.54	3.55	91.69
Rajbaushi (N=145)	M	41.52	54.13	2.21	56.34	2.14	13.92	5.15	73.69
Muslim (N=114)	M	40.83	53.55	3.25	56.80	2.37	13.83	5.80	71.88
Rabha (N=84)	F	42.26	52.73	1.43	54.17	3.57	13.87	8.44	78.01

TABLE 3

*Distribution of patterns handwise, and the indices derived out of them.*

Population groups	Hand and No of Fingers	Frequency of pattern types			Indices		
		Whorl %	Loop %	Arch %	P. I. I.	Ar/W. I.	W/L. I.
	L. Hand						
Brahmin	(N=555)	34.95	58.38	6.67	12.82	19.08	59.86
Kayastha	(N=599)	38.23	60.43	1.33	13.68	3.47	63.26
Namasudra	(N=540)	43.33	55.00	1.67	14.16	3.85	78.78
Rajbanshi	(N=725)	38.48	58.90	2.62	13.58	6.80	65.33
Muslim	(N=569)	37.08	60.46	2.46	13.46	6.63	61.32
Rabha (F)	(N=420)	45.00	50.95	4.05	14.09	9.00	88.32
	R. Hhand						
Brahmin	(N=555)	41.62	53.15	5.23	13.63	12.56	78.30
Kayastha	(N=600)	46.50	51.67	1.83	14.46	3.93	89.99
Namasudra	(N=540)	50.74	47.59	1.67	14.90	3.19	106.61
Rajbanshi	(N=725)	44.55	53.79	1.65	14.28	3.70	82.82
Muslim	(N=570)	44.56	53.16	2.28	14.22	5.11	83.82
Rabha (F)	(N=420)	39.52	57.38	3.09	13.64	7.81	68.87

TABLE 4

*Mean P. I. I and its Statistical Constants*

Population groups	N	Range	P. I. Index	
			Mean $\pm$ S. E.	S. D. $\pm$ S. E.
Brahmin	111	2.0-20.0	13.23 $\pm$ 0.37	3.93 $\pm$ 0.26
Kayastha	120	2.0-20.0	14.07 $\pm$ 0.31	3.45 $\pm$ 0.22
Namasudra	108	8.0-20.0	14.54 $\pm$ 0.30	3.15 $\pm$ 0.21
Rajbanshi	145	3.0-20.0	13.92 $\pm$ 0.29	3.53 $\pm$ 0.20
Muslim	114	9.0-20.0	13.83 $\pm$ 0.30	3.28 $\pm$ 0.21
Rabha (F)	84	5.0-20.0	13.87 $\pm$ 0.36	3.33 $\pm$ 0.25

TABLE 5

*Values of 't' for differences in mean P. I. I. between the population groups*

	Groups compared	Values of 't'	Remarks
1	Brahmin and Kayastha	1.71	For $n = \infty$ , $t = 1.96$ at 0.05 level
2	„ and Namasudra	2.73*	* Significant
3	„ and Rajbanshi	1.44	
4	„ and Muslim	1.25	
5	„ and Rabha (F)	1.23	
6	Kayastha and Namasudra	1.07	
7	„ and Rajbanshi	0.34	
8	„ and Muslim	0.55	
9	„ and Rabha (F)	0.42	
10	Namasudra and Rajbanshi	1.48	
11	„ and Muslim	1.69	
12	„ and Rabha (F)	1.42	
13	Rajbanshi and Muslim	0.21	
14	„ and Rabha (F)	0.11	
15	Muslim and Rabha (F)	0.09	

# MIDDLE PHALANGEAL HAIR AMONG CERTAIN GROUPS OF BIHAR

GURU CHARAN GHOSH

(Received on 13 October 1968)

**Abstract :** Data on middle phalangeal hair were collected from nine groups (male) of Bihar. The pooled data show heterogeneity. Three distinct homogeneous clusters are observed, and the incidence of middle phalangeal hair is found to follow the social ladder.

## *Introduction*

**T**HE present article is a report on the distribution of middle phalangeal hair among certain groups of Bihar. The data were collected from three districts of Bihar (Table 1) namely, Monghyr, Bhagalpur and Santal Parganas in the year 1965-66 and consists of male populations of nine groups, such as, Brahmin, Rajput, Kayastha, Yadav, Tanti, Dusadh, Chamar, Muslim and Santal. Altogether 675 males were tested having the mean age of 30.61. The presence or absence of hair or the active follicle on the middle phalangeal segments of both the hands was observed with the help of magnifying lens.

## *Analysis*

Table 1 gives the picture of incidence of middle phalangeal hair of the nine male groups collected from Monghyr, Bhagalpur and Santal Parganas of Bihar. It varies from 15.38% to 49.41% and the highest percentage of incidence was found among the Brahmin and the lowest among the Chamar. It is interesting that these two groups stand on the two extremes of social hierarchy. The pooled data of nine groups are tested for homogeneity and is found to be heterogeneous ( $\chi^2_{8df} = 30.326$ ,  $0.001 > P$ ).

Yadav, Dusadh and Muslim are considered to form a single cluster (Cl. I) on the basis of similarity in percentage of incidence. As the Brahmin, Rajput and Kayastha samples showed the higher percentage than these three groups, they have been grouped under cluster II. Similarly the remaining Santal, Tanti and Chamar samples are put under cluster III, as they show comparatively low percentage. These three clusters are tested for homogeneity within themselves and found to be homogeneous (Table 2). Table 2 shows that cluster I differs significantly from both, cluster II ( $\chi^2_{1df} = 5.706$ ,  $0.02 > P > 0.01$ ) and cluster III ( $\chi^2_{1df} = 8.775$ ,  $0.01 > P > 0.001$ ). Similarly cluster II is tested for homogeneity with cluster III and found to be heterogeneous ( $\chi^2_{1df} = 25.201$ ,  $P > 0.001$ ). Table I shows a trend in the proportion of incidence as per social hierarchy. Therefore the data are arranged according to social hierarchy (Prasad 1957) and the Muslim and Santal samples are excluded being non-caste groups. The linearity of the trend is tested as suggested by Armitage (1955). The departure from linearity is found to be statistically not significant ( $\chi^2_{5df} = 4.887$ ,  $0.50 > P > 0.30$ ).

Table 3 shows that there is no significant bimanual difference in the distribution of middle phalangeal hair. In other words, both the hands have got equal chances to bear the incidence.

From Table 4 it appears that out of 675 individuals examined there are only 29 persons who are unilaterally affected. Out of these 29 individuals, only 18 persons bear the trait on left hand while right is free. The remaining 11 persons have got middle phalangeal hair only on right hand, left hand being free from hairs.

Fingers from index to little are represented by the numerals 2 to 5 to show the distribution of middle phalangeal hair by digital combination. Zero signifies absence of incidence (Rakshit 1961). Table 5 shows the maximum frequency on 0340 combination followed by 0345, 0040 etc. Brahmins are having highest number of incidence on 0040 followed by 0340 combination. In case of Rajput, Yadav, Muslim, Dusadh, Santal and Tanti it is found maximum on 0340 combination.

Only among Kayastha and Chamar the digital combination of 0345 bears the highest frequency of incidence of middle phalangeal hair.

Table 6 gives a picture of fingerwise distribution of middle phalangeal hair and  $4 > 3 > 5 > 2$  formula holds good for all the cases except Rajput. This may possibly be due to small sample size. It is also to be noted that the 2nd digit is free from incidence in Kayastha, Dusadh, Santal, Tanti and Chamar and though present among rest of the groups is not adequately represented.

Table 7 gives the picture of symmetrical and asymmetrical combination of hands in respect of middle phalangeal hair. Individuals with symmetrical combinations are overwhelmingly larger and this is true for all the groups. Taking all the groups together, three out of every four persons show symmetrical combination.

### Comparison

The present data are compared with the available materials of respective groups in other States. The present Brahmin group is compared against the Brahmin group of West Bengal (Bhattacharjee 1956), Madhya Pradesh (Dutta 1964) and Uttar Pradesh (Singh & Dutta 1955). The difference in sample percentages are not statistically significant ( $chi^2_{3df} = 6.460$ ,  $0.10 > P > 0.05$ ), neither Rajput group of Madhya Pradesh (Dutta '64) is found to be different from that of Bihar ( $chi^2_{1df} = 0.0000444$ ,  $0.99 > P > 0.98$ ). The present Muslim data are tested against the Muslim of West Bengal (Bhattacharjee 1956) and Madhya Pradesh (Dutta 1964) together and found to be heterogeneous ( $chi^2_{3df} = 9.772$ ,  $0.01 > P > 0.001$ ). Bihar Muslims differ significantly from those of West Bengal ( $chi^2_{1df} = 7.468$ ,  $0.01 > P > 0.001$ ) and also of Madhya Pradesh ( $chi^2_{1df} = 6.136$ ,  $0.02 > P > 0.01$ ).

### Discussion

The present data do not show any bimanual difference in the incidence of middle phalangeal hair. Out of 675 individuals examined, only 29 persons (4.2%) are unilaterally

affected. The incidence of the trait is found maximum on the ring finger and least on the index and it follows the accepted formula of  $4 > 3 > 5 > 2$ . Presence of hair on index finger is a rare phenomena. In the present study maximum number of affected individuals belong to the 0340 combination followed by 0345, 0040 etc. There is preponderance of identical hands and three individuals out of every four do show bimanual symmetry.

The data comprised of nine male groups of Bihar. The pooled data of nine groups show heterogeneity. Brahmin and Chamar stand on the two extreme positions as they do so in social hierarchy. Three distinct homogeneous clusters are observed. Brahmin, Rajput and Kayastha forming one cluster, the Yadav, Dusadh and Muslim the second and the Santal, Tanti and Chamar the third. These three clusters are tested for homogeneity with each other and found to be heterogeneous. Incidence of middle phalangeal hair is found to follow the graded rule of social hierarchy excepting Dusadh and Tanti and it is just these two groups which have interchanged their position. Therefore the data are arranged as per social hierarchy (Prasad 1957) placing Tanti and Dusadh to their own social position and Santal and Muslims are excluded for the present purpose being non-caste group. To test the validity of this trend a statistical test proposed by Armitage (1955) is applied. Departure from linearity is not statistically significant. Therefore the data suggest some association in the proportion of incidence of middle phalangeal hair and social hierarchy of the groups.

The present data are compared with the available material to test the homogeneity. It is seen that the Brahmin of Bihar is homogeneous with that of Madhya Pradesh, West Bengal and Uttar Pradesh though they belong to different ecology. This also holds good in case of Rajput of Bihar and Madhya Pradesh. The present Muslim data are compared against the Muslim of West Bengal and Madhya Pradesh and it shows heterogeneity. Thus it leads us to state that the Muslims of Bihar are distinctly apart in respect of middle phalangeal hair from Muslims of both the States.

## ACKNOWLEDGEMENTS

The author deeply acknowledges his gratefulness to Sri H. K. Rakshit for his valuable suggestions in preparing this article and to Sri R. B. Bhale for all the statistical analysis of the data.

## REFERENCES

- Armitage, P. 1955 : Test for linear trends in proportions and frequencies. *Biometrics*. 11, 375-386.
- Bernstein, M. M. and Burks, B. S. 1942 : The incidence and mendelian transmission of mid-digital hair in man. *Journal of Heredity*. 33, 45-53.
- Bhattacharjee, P. N. 1956 : A genetic survey in the Rarhi Brahmin and Muslims of West Bengal. *Bull. Dept. Anth.* 5 : 1, 18-28.
- Boyd, W. C. and Boyd, L. G. 1937 : New data on blood groups and other inherited factors in Europe and Egypt. *Am. Jr. Phy. Anth.* 23 : 1, 49-70.
- Danforth, E. C. 1954 : Distribution of hair on the digits of man. *Am. Jr. Phy. Anth.* 4 : 2, 189-204.
- Dutta, P. C. 1965 : On the variability of middle phalangeal hair among Indian population. *J. R. A. I.*, 95 : 1, 115-126.
- Garn, S. M. 1951 : The use of middle phalangeal hair in population studies. *Am. Jr. Phy. Anth.* 9 : 3, 325-334.
- Prasad, N. 1957 : The myth of the caste system. *Samjna Prakasan. Patna*.
- Rakshit, H. K. 1961 : Plea for study of pes phalangeal hair. *Man in India*. 41 : 2, 100-110.



TABLE 1

*Frequencies of middle phalangeal hair among different groups (male) of Bihar.*

Group	Mean age	Sample size	With middle phalangeal hair frequency	percentage	Place of origin
Brahmin	31.00	85	42	49.41	Monghyr, Bhagalpur
Rajput	27.88	25	11	44.00	and Santal Parganas
Kayastha	32.76	83	13	39.39	Bhagalpur
Yadav	24.83	65	22	33.85	Monghyr, Santal Parganas
Muslim	31.18	134	45	33.58	Monghyr, Bhagalpur and Santal Parganas
Dusadh	32.09	66	22	33.33	Monghyr, Bhagalpur
Santal	33.89	139	36	25.90	Monghyr, Bhagalpur and Santal Parganas
Tanti	31.46	50	10	20.00	Monghyr
Chamar	30.88	78	12	15.38	Bhagalpur and Santal Parganas
Total	30.61	675	213	31.56	

$\chi^2_{8df} = 30.326, P > 0.001$

TABLE 2

*Chi<sup>2</sup> results of Different Groups*

Sr. No.	Groups compared	Code if any	Chi <sup>2</sup> with P level	Results
1	Brahmin, Rajput, Kayasth	Cl II	2 df, 1.022, 0.70 > P > 0.50	Homogeneous
2	Yadav, Muslim, Dusadh	Cl I	2 df, 0.0197, P > 0.99	"
3	Santal, Tanti, Chamar	Cl III	2 df, 3.364, 0.20 > P > 0.10	"
4	Cl I and Cl II		1 df, 5.706, 0.02 > P > 0.01	Heterogeneous
5	Cl II and Cl III		1 df, 25.201, P > 0.001	"
6	Cl I and Cl III		1 df, 8.775, 0.01 > P > 0.001	"

TABLE 3

*Handwise distribution of Middle Phalangeal Hair among different groups (Male) of Bihar*

Groups	Left and Right hand combined	Right	Left
Brahmin	42	37	40
Rajput	11	11	10
Kayasth	13	13	11
Yadav	22	21	21
Muslim	45	40	44
Dusadh	22	19	20
Santal	36	33	35
Tanti	10	10	10
Chamar	12	11	11
Total	213	195	20

TABLE 4

*Unilateral distribution of Middle Phalangeal Hair among different groups (Male) of Bihar*

Group	Left free, Right affected	Right free, Left affected	Total
Brahmin	2	5	7
Rajput	1	—	1
Kayasth	2	—	2
Yadav	1	1	2
Muslim	1	5	6
Dusadh	2	3	5
Santal	1	3	4
Tanti	—	—	—
Chamar	1	1	2
Total	11	18	29

TABLE 5

*Digital combination with Middle Phalangeal among different groups (Male) of Bihar*

Group	Brahmin	Rajput	Kayastha	Yadav	Muslim	Dusadh	Santal	Tanti	Chamar	Total
2345	2	2	-	2	2	-	-	-	-	8
0345	15	7	10	12	32	4	18	2	8	108
0300	1	2	1	-	1	-	1	-	1	7
0340	25	9	8	18	33	24	37	14	7	175
2300	-	1	-	1	-	-	-	-	-	2
0045	4	-	-	-	1	1	-	-	-	6
0040	30	-	5	9	15	10	12	4	6	91
0000	86	28	40	86	178	88	206	80	132	924
Total	163	49	64	128	282	127	274	100	154	1321

TABLE 6

*Fingerwise distribution of Middle Phalangeal Hair among different groups (Male) of Bihar*

Group	Fingers			
	2	3	4	5
Brahmin	2	43	76	21
Rajput	3	21	18	9
Kayastha	-	19	23	10
Yadav	3	33	41	14
Muslim	2	68	83	95
Dusadh	-	28	39	5
Santal	-	56	67	18
Tanti	-	16	20	2
Chamar	-	19	21	8
Total	10	300	388	122

TABLE 7

*Symmetrical and Asymmetrical combination of Middle Phalangeal Hair among different groups (Male) of Bihar*

Group	Symmetrical combination	Asymmetrical combination	Total
Brahmin	27	15	42
Rajput	9	2	11
Kayastha	11	2	13
Yadav	12	10	22
Muslim	33	12	45
Dusadh	13	9	22
Santal	30	6	36
Tanti	10	—	10
Chamar	9	3	12
Total	154	59	213

TABLE 8

*Comparison of frequencies of Middle Phalangeal Hair among Male Brahmins of West Bengal, Madhya Pradesh, Uttar Pradesh and Bihar*

Group	Place of investigation	Sample size	With Phalangeal Hair		Author
			Abs. No.	Percentage	
Rarhi Brahmin	West Bengal	191	111	58.12	Bhattacharjee '56
Brahmin	Madhya Pradesh	96	44	45.83	Dutta '64
Mohyal Brahmin	Uttar Pradesh	71	31	43.66	Singh and Dutta '55
Brahmin	Bihar	85	42	49.41	Present study

$\chi^2_{3df} = 6.460,$

$0.10 > P > 0.05$

Homogeneous

TABLE 9

*Comparison of frequencies of Middle Phalangeal Hair among  
Male Rajputs of Madhya Pradesh and Bihar*

Place of investigation	Sample size	With Phalangeal Hair		Author
		Abs. No.	Percentage	
Madhya Pradesh	49	23	46.94	Dutta '64
Bihar	25	11	44.00	Present study
$\chi^2_{1df} = 0.0000444, 0.99 > P > 0.98$				Homogeneous

TABLE 10

*Comparison of frequencies of Middle Phalangeal Hair among  
Male Muslims of West Bengal, Madhya Pradesh and Bihar*

Place of investigation	Sample size	With Phalangeal Hair		Author
		Abs. No.	Percentage	
West Bengal	203	100	49.26	Bhattacharjee '56
Madhya Pradesh	101	51	50.49	Dutta '64
Bihar	134	45	33.58	Present study
$\chi^2_{2df} = 9.772, 0.01 > P > 0.001$				Heterogeneous

# FINGERPRINTS, COLOUR BLINDNESS, AND OTHER FEATURES IN THE MIRIS OF ASSAM

R. P. SRIVASTAVA\*.

**Abstract :** The finger dermatoglyphics of the Miris indicate the presence of higher frequency of loops than whorls. The mean ridge counts also appear to be high. No case of vision defect has been observed. The frequency of tongue folders observed in the Miris conforms to the general observation.

## *Introduction*

THE Miris are divided into two major groups; the Barogam, and the Doagam. The Barogam group consists of two main clans; the Doley, and the Pegu. The second major group Doagam is divided into eight sub-groups; the Pagro or Chutia Miri, Dambook, Chayang, Moying, Dyan, Delo or Lachan Gonya, Tayu-Taye or Joau Gonya, and Mirang each having a number of clans of its own. The entire community of the Miris constitutes one endogamous group. Cross-cousin marriages are practised by the Miris but parallel-cousin marriages are avoided.

There has been no systematic investigation into the genetic composition of the Miris except that one finds a reference to their finger dermatoglyphics in Chakravartti's paper (1963). The author got an opportunity to visit few Miri villages in the Dhemaji subdivision of district Lakhimpur from where the present data were collected.

## *Material and Methods*

The samples consists of finger prints and other observations from 37 unrelated males belonging to the Doley and Pegu clans of Barogam ; one of the major divisions of the Miris.

---

The author is Reader and Head of the Department of Anthropology, Dibrugarh University, Assam.

The usual schemes of Cummins and Midlo (1961) were employed for formulating the finger pattern types. Arches include diminutive loops and much reduced whorls which lack a ridge count. For ridge counting rules adopted by Holt (1949) were used, Ishahara chart was used to examine colour vision. Since all the subjects could read, there was no difficulty in asking them to read all the 25 plates of Ishihara chart. As regards the tongue folding the subjects were asked to bring the sides of the tongue over the top as I demonstrated being a tongue folder. Somatoscopic observation was made for the ear lobe.

### *Results*

Percentages of finger patterns in both the hands are shown in Table 1. It is observed that the main pattern types are distributed practically in the same order in both the hands except the sub-types of whorls. Finger patterns of both the hands combined together indicate that loops are much more than the whorls.

Mean index of pattern intensity and mean ridge counts are shown in Table 2. Index of pattern intensity is a measure of the number of triradii per individual. Its values range from 0, all arches to 20, all whorls. In the present series the mean index of pattern intensity obtains a value of  $13.40 \pm 0.39$ . Useful interpretation of the fingerprint data is also secured from the analysis of the ridge counts. The mean ridge count in the present sample is  $143.60 \pm 5.25$ .

Colour blindness is one of the sex-linked conditions. There are different kinds of colour blindness. There are persons who can not distinguish any colours. There are others who have some slight defect in their vision and as such can not distinguish red from green. Red-green blindness has been found to be the commonest of all defects of sex-linkage. In the present investigation not a single case was found for any of the vision defects.

Ability to roll the tongue i.e., to bring the sides of the tongue over the top is inherited as a simple dominant whereas the inability to roll the tongue is inherited as a recessive

(Ashley Montagu 1960). In the present series about 64 per cent are the tongue folders (Table 3).

There are many different features of the ears which are inherited independently. The lobe of the ear may hang free or it may be attached to the head. The former is determined by a dominant gene and the latter by a recessive gene (Ashley Montagu 1960). The present study reveals that 70 per cent of the Miris have attached lobes (Table 3).

### *Comparison and Conclusions*

Chakravartti (1963) has reported two male samples of Miris ; in one of the samples he has shown equal distribution of whorls and loops and in the other lowering of whorls. But in the present sample of Miris an excess of loops over whorls is observed. In other Mongoloid tribes of Assam one can find both the situations clearly indicated by Chakravartti. Data on ridge counts are not available from any of the Assam tribes studied so far from the point of view of dermatoglyphics. Srivastava (1965) observed a mean ridge counts of  $126.65 \pm 1.81$  in the Tharus of U. P. a Mongoloid tribe. In the Miris a much higher mean ridge counts of  $143.60 \pm 5.25$  has been found.

Colour blindness in Indian populations has been found to vary around 4 per cent with the exception of the Toda (12%) (see Bhattacharya, 1960). Ashley Montagu (1960) reported that about 65 per cent of people can roll the tongue. The present observation is in conformity with what Ashley Montagu has reported.

### ACKNOWLEDGEMENTS

The author is thankful to Dr. N. N. Pegu of the Civil Dispensary, Dhemaji, Mr. D. Doley, Lecturer, Dept. of Sociology, Dibrugarh University and Mr. S. Pegu, a student of M. A. (final) sociology, for their help in the field.



R E F E R E N C E S

- Ashley Montagu, M. F.      1960 : Human Heredity, *A Mentor Book*.
- Bhattacharya, D. K.      1966 : Frequency of colour blindness among the Anglo Indians of India. *J. De Genet. Hum* ; 15 ; pp. 3-6.
- Chakravartti, M. R.      1963 : Ethnic bearing of the dermatoglyphic studies in India *Act. Genet. Gene*, 12 : pp. 374-404.
- Cummins, H. and C. Midlo   1961 : Fingerprints, Palms and Soles. An Introduction to Dermatoglyphics. *Dover Publication*.
- Holt, Sarah B.            1949 : A quantitative survey of the fingerprints of a small Sample of a British population. *Ann. Engen. London*, 14 : pp. 329-338.
- Srivastava, R. P.         1965 : A quantitative analysis of the finger prints of the Tharus of Uttar Pradesh. *Am. J. Phys. Anthropol.* 21 : pp. 69-76.

TABLE 1  
*Percentages of finger pattern types in the Miris.*

No. Side	WHORLS			Total	LOOPS			ARCHES		Total
	Lateral pocket and twin loop	Central pocket	Accidental		Radial	Ulnar	Total Tented	Others		
R 30.81	2.16	4.32	-	37.29	1.08	57.83	58.91	1.08	2.70	3.78
L 24.32	3.78	8.64	1.08	37.83	1.08	57.29	58.37	1.08	2.70	3.78
R+L 27.56	2.97	6.48	0.58	37.56	1.08	57.56	58.64	1.08	2.70	3.78

TABLE 2

*Mean index of pattern intensity and mean ridge counts in the Miris*

No.	Index of Pattern Intensity			Ridge Counts			
	Mean	S. E.	S. D.	No.	Mean	S. E.	S. D.
37	13.40	0.39	2.33	30	143.60	5.25	28.73

TABLE 3

*Tongue folding and the ear lobe in the Miris.*

Total No.	TONGUE FOLDING		EAR LOBE						
	No.	Folder %	No.	Non-folder %	Total No.	Separate %	Attached %		
36	23	63.88	18	36.11	36	11	30.55	25	69.44

# Notice

**MAN IN INDIA** invites articles, notes and communications from those who are interested in anthropology, archaeology, linguistics and folk-culture. Manuscripts sent for publication must be typewritten (double-spaced) on one side of the paper with a covering letter specifying the number of reprints required, 25 copies of which are supplied free to contributors.

Articles should also be accompanied by an abstract of the paper covering not more than 10 lines. Contributors are also requested to type their official designation and personal addresses at the foot of the first page of the typescript. Contributors are requested not to send any such article which has already been sent to some other journal.

All correspondence should be addressed to the Editor, *not by name*, to the Office of **Man in India**, 18 Church Road, Ranchi, Bihar, India. Arrears and current subscriptions should be sent to the Manager, **Man in India**, Ranchi, Bihar, India. All publications meant for exchange should be sent to Ranchi.

If subscribers do not receive **Man in India** in time, they should please send their complaints to the office by the following date, after which it would not be possible for the Management to furnish them with duplicate copies if the original ones have not been received.

No. 1..	15th April
No. 2	15th July
No. 3	15th October
No. 4	15th January

Editor : **Nirmal Kumar Bose, M. Sc., F. N. I**

**Annual Subscription :**

Inland : Rs. 15'00      Foreign : 25s. or 5 dollars or its equivalent  
Single copy : Rupees Four.

**Foreign subscribers are requested to pay subscription either in Sterling or Dollar.**