

The Madras Agricultural Journal

(ORGAN OF THE M. A. S. UNION)

Vol. XXXI

DECEMBER 1943

No. 12.

EDITORIAL

Increasing Production of Milk That the production of milk in the country is short and inadequate and needs to be improved, and improved greatly, needs no emphasis. It is also true that for achieving this end, a well-thought-out, long-sustained, definite and vigorous policy in breeding is required, combined with proper feeding, care and management of cattle. The essential principles in breeding for milk enunciated by Mr. John Hammond in his paper on "Improved Breeding for Milk Production" and printed elsewhere in this issue, is of more than passing interest to us. He emphasises the importance of selecting the bulls also, just as in the case of cows, and this is a point that the breeders are apt to miss. That the production of milk is increased by milking cows three times a day has been the experience of some. Milking three times a day would result in stimulating the secretion of milk, the development of the milk producing tissue and an increased blood supply to the udder, especially when adopted from the first lactation onwards. These merit the attention of those responsible for advising the country about the development of cattle and the increased production of milk.

What Mr. Hammond says would appear to be particularly applicable to India. He points out how by using proven bulls exclusively for two generations, a low producing, non-descript herd could be made into a herd of reasonably good production. This finding is of special interest to this country where the cows are mostly non-descript animals and there are no 'proven bulls'. There is no such definite policy for improving milk by breeding, excepting a kind of grading-up. There is also no general system of recording milk production and no method of knowing the parentage of animals. The recording of the production of milk from individual animals and of the parentage of animals, both milking cows and breeding bulls, as a general practice, would appear to be the first step in the improvement work. Such recording alone would enable one to pick out good animals and animals with outstanding merit. The country is fortunately not wanting in good animals. The recording of milk done at the Government Stations and similar institutions has shown that some buffalo-cows have passed the 7,500 lb. milk limit and some cows the 10,000 lb. mark, in one lactation. There are possibly many such animals in the country. Such milkers should provide the necessary bull calves for initiating the breeding work. The

capacity of these bull calves to transmit their milk characters to their daughters may need to be ascertained by systematic milk recording. When the bulls are known to transmit their milk characters, they should be utilised to the fullest extent for breeding purposes.

Each bull can serve a maximum of 80 to 100 cows in a year, on a liberal estimate, while the same bull can fertilise about 1,000 cows, if artificial insemination is resorted to. Artificial insemination is a regular large scale practice followed in Soviet Russia, and the United States of America, countries that attempt things on a mass scale, with staggering results in the end. The adoption of artificial insemination assumes a large cow population normally. Individual owners do not maintain big herds in the country, but the required number of cows could be secured through the co-operation of cow-owners in adjacent villages. Methods of preserving the semen for a number of days have been developed and these are being improved upon everyday, and artificial insemination has immense possibilities and a big future. It is admitted that there are considerable difficulties to be surmounted in the breeding programmes suggested, but really nothing great is achieved without adequate effort. These will tax all the resources of the people in charge of improvement work and to them we commend the above.

Good breeding methods alone are not enough. Side by side with breeding should commence a better system of feeding, care and management. We are not suggesting or asking for the impossible. Other countries have done it and it should not be impossible in this country. Increasing the production and consumption of milk is a national necessity and should not be postponed any longer without sacrificing the little health and the poor stamina of the people.

The feeding of animals has to be rationalised, if the increased production of milk is to be secured and kept up. More fodder will have to be produced and quality fodder will have to be aimed at. It will be necessary for the fodders to replace to an extent other crops, whose production may in consequence get reduced slightly. It is inevitable. Even as it is, the production of food grains in this country is in defect and a suggestion to reduce it further might sound fallacious. It is said that the war has emphasised the necessity for every country being self-contained with regard to the production of the primary food grains. The other view is that densely populated countries should specialise in the production of the necessary perishable food produce like milk, fruits, vegetables, etc. and import grains from less populous and extensive-cultivation areas or countries. War cannot be a perpetual phenomenon and national programmes should not be drawn up with war conditions as a primary basis, leading to a perpetual conflict between peace conditions and national programmes. We would rather say, be self-contained with regard to production of food grains, if possible, but certainly be self-contained with regard to the perishable vegetable, fruit and milk produce, war or no war.

Fish Rearing in Paddy Fields on the Agricultural Research Station, Aduturai, Tanjore District

By M. ANANDAN, L. Ag.,
District Agricultural Officer, Tanjore

There are over a million acres of wet land of very flat nature in the Cauvery delta which are under swamp paddy from June to January. The irrigation source is the Cauvery river and its numerous distributories. Water from the river is conveyed through the main channels from which, branch or field channels take off and deliver the water direct into the paddy fields. With the construction of the Mettur Reservoir, the supply of water has been so well regulated that there is hardly any dearth of supply at any time during the irrigation season. With such assured water supply for 8 months in the year the writer, as Superintendent in charge of the Agricultural Research Station, Aduturai, thought it worth while to start rearing of fish in paddy fields with suitable precautions. The experiment was started in 1933—34 paddy season. As indigenous varieties of fish including many species of carps naturally occur in the river water, artificial rearing of the fry was not attempted, but precautions were taken to see that fish that once entered the block of land selected for the experiment were never allowed to escape, by the provision, at the drainage vents of 'V' shaped bamboo screens which allowed entry of the fish into the paddy fields but not their escape (see fig. 1.)

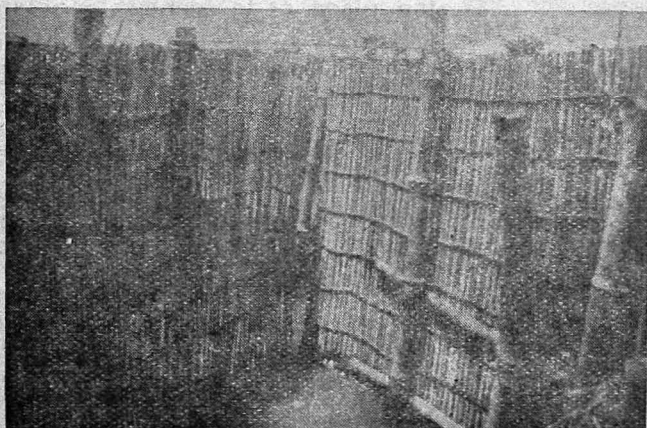

Fig. 1. 'V' shaped bamboo screen.

was allowed to enter the block of land was completely screened off by close meshed wire netting. The provision of 'V' shaped screen was made at the drainage vent, purposely to take advantage of the natural tendency of all fish to swim against the current. Streams of fish could be seen forcing

their way through the narrow slit in the 'V' shaped screen and against the flowing water. The block of land selected was about 12 acres in extent with two parallel rows of fields, 14 in each row, with a long common bund dividing the two rows of plots. The length of this common bund was nearly 1500 feet running west to east. These fields are planted to two crops of paddy during the season of 8 months, the first crop occupying the ground

from June to the end of September and the second crop from October to the end of January or the middle of February. The fish on entering were free to move about in all the fields of the experimental block. But it was soon realised that conditions became unsuitable for fish to thrive when the fields were ploughed or when water went down in depth (below

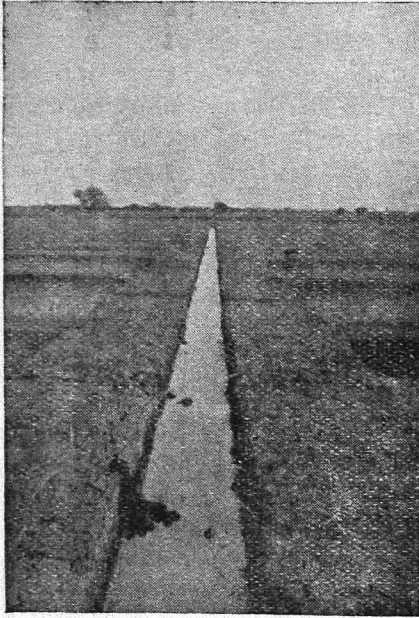

Fig. 2. Central trench connecting the fish pond.

2 inches) in the fields. Young fish, particularly of carps, were also noticed to die in large number when temperature of the water in the experimental fields rose beyond 36°C . Such high temperature prevails on almost all days from June to the middle of September during the hours 12 noon to 3 in the after-noon in the unplanted fields in the delta. Within 20 days after planting a paddy crop, the shade produced by the rapidly tillering paddy plants was sufficient to prevent the rise in temperature of the water in the fields and to protect the young fish from heat stroke. To save the fish from the ill-effects of the above conditions, a central trench 2 feet in width and 2 feet in depth was dug in the place of the central long bund. (See fig. 2.) This trench was in turn connected to a 6 feet wide and 8 feet deep trench of about 26 feet length

at the head of the block of land through which water was let in for irrigating the whole block.

At the end of the paddy season in January, the water supply is cut off from Mettur and in consequence, the rivers, the channels and the paddy fields dry up with the result that the fish either perish or are caught by the people irrespective of their size or weight. A certain number, of course, escape into the numerous village tanks scattered all over the delta but a large proportion of the young and small fish generally perish. The big trench at the head of the experimental block served to give shelter to the fish and carry them over to the next irrigation season through the dry months, February to May. This trench was subsequently widened and deepened into a fish pond occupying about 7 cents in area and 300 to 400 lb. of mature fish are caught and sold annually now, though the long central trench was filled up and the experiment of rearing fish in the paddy fields discontinued after three seasons, in 1936.

The following varieties of fish were found to thrive well in the fish pond of which *Valai* or fresh water shark (*Callichrous bimoculatus*) alone was not found to live in paddy fields. It requires deep water to thrive.

	Tamil Name	Scientific Name	Remarks
1.	Valai	<i>Callichrous bimaculatus</i> (Bloch)	
2.	Viral	<i>Ophiocephalus striatus</i> (Bloch)	
3.	Sani Kandai	<i>Barbuis pennauratus</i> Day	Carp
4.	Sel Kandai	<i>Lebec fimbriatus</i> (Bloch)	Carp
5.	Venkandai	<i>Cirrhinus cirrhosus</i> (Bloch)	Carp
6.	Kilathi	<i>Aoria Vittala</i> (Bloch)	
7.	Uluvai	<i>Glossogobius ginis</i> (H. B.)	
8.	Theli	<i>Hoteropneustez fossilis</i> (Bloch)	
9.	Arai—(Fe.)	<i>Rhyncobdella aculiata</i> (Bloch)	
10.	Pana-Eychi Kandai	<i>Anabas testudineus</i> (Bloch)	Carp
11.	Rattu—(Prawn)	<i>Pataemon</i>	
12.	Koravai	<i>Ophiocephalus punctatus</i> (Bloch)	

It would be seen from the list that not only carp but other fish mostly predacious in nature also get into the paddy fields and finally into the fish pond when fish are allowed free entry into the fields from rivers and channels. If carp alone are to be reared, artificial rearing of the carp fry will have to be undertaken for liberation into the paddy fields during the irrigation season, to the exclusion of all other kind.

The writer has not noted any one of the carps breeding in still water in the paddy fields but large numbers of their young fry are seen in the channel and river water, thereby showing that breeding of these carps takes place only in running water. *Ophiocephalus striatus* and *Ophiocephalus punctatus*, were found to breed freely in paddy fields from the months of September to November. About 10,000 eggs are laid on a circular raft made by sticking together cut leaves of paddy and grasses. The young of *Ophiocephalus striatus* are blood red in colour and when the young fry move in water the trail looks bloody; 3000 to 4000 young ones are noted in one brood. Of the carps, *Labeo fimbriatus* attains the biggest size. A full grown specimen would weigh a pound while others vary in weight from 3 to 8 ounces when full grown. None of these carps attain their full size within the 8 months of the paddy season as none of them weighed more than 4 oz. during the time. So it is essential that the immature fish should be carried over through the summer to the second season in a fish pond if the maximum size or weight of the fish is to be obtained.

A fresh fish pond was dug on the station and stocked with *Gourami* fingerlings in April, 1940. These were fed on groundnut cake and when specimens were caught at the end of two years, many of them had attained 5 lb. in weight. These fish have spawned freely in the pond which is 8 feet in depth and more than 500 young fry are now available. It is proposed to liberate 100 fingerlings of this famous fresh water carp in the paddy fields next paddy season taking suitable precautions to note what size they attain within 8 months of the irrigation season in comparison with the growth of the indigenous carps mentioned above.

There is no doubt that it is practicable to rear fish in the paddy fields of the Cauvery delta provided the cultivators take care to provide small fish

ponds of, say, 5 cents in area in 10 acre blocks of paddy fields to carry immature fish through the summer from one paddy season to the next so that fish could attain their maximum size and weight. Carp fry alone should be encouraged to grow in the paddy fields by excluding all the predacious fish. If exotic varieties of carp, like *Osphronienus gourami*, are able to thrive in paddy fields, the yield of fish in paddy fields could be greatly increased. An average catch of 50 lb of fish from an acre will indeed, represent a great addition to the supply of food in the country, particularly so when it is a first class source of animal protein.

Dehydrated Banana Products and Their Food Value

By K. C. NAIK, B. Ag. (Bom.), M. Sc. (Bristol),

Fruit Specialist, Kodur (Cuddapah Dt.)

Introduction According to a recent estimate by the Provincial Marketing Officer, Madras, bananas are grown in the province on an area of nearly 140,000 acres. The estimated annual production of fresh banana fruits is of the order of 1,133,000 tons. Of these, *Poovan* accounts for more than half with an annual production of 741,000 tons. *Monthan*, *Nendran*, *Kunnan*, *Mauritius*, *Rasthali*, *Pachanadan*, Hill bananas and *Chakerakeli* follow next in order of importance, the first two claiming a production of nearly 90,000 tons each per year.

The pre-war exports outside the producing districts were over 910,000 railway maunds, of which the district of Trichinopoly claimed roughly 529,000 maunds, East Godavari, West Godavari and Madura 100,000 maunds each, and the districts of Salem and South Arcot about 70,000 maunds each. The exports by rail outside the province ranged from 80,000 to 90,000 railway maunds, mainly from the Cauvery area to the Mysore State and from 60,000 to 120,000 railway maunds from the Godavari area to the Nizam's Dominions and North India. In effect, the pre-war exports of 140,000 to 210,000 railway maunds may be taken to represent the annual surplus of fresh banana fruits in the province.

Provided the transportation facilities are improved and the demand for Madras bananas is fostered within and outside the province, there is much scope for extending the banana cultivation particularly in the heavy rainfall tracts of Malabar and on the hills of the Madura District where the crop can be raised under rainfed conditions. Such an extension seems desirable as the yield of bananas per acre surpasses that of the staple food crops, and the fresh ripe banana is recognized to be a very valuable and delicious food.

Restrictions in transportation facilities during the war may hinder the course of development of banana-growing industry in certain producing areas, and consequently, gluts in some producing regions and scarcity in others may become the features during the present emergency period. Dehydration of banana suggests itself as a means to tide over such temporary difficulties. The dehydrated bananas can, moreover, be transported

more cheaply and conveniently, and they may also help to alleviate the food scarcity to some extent.

The value of banana flour as a food has long been known in some parts of the province. The preparation of banana meal by sun-drying has, therefore, been practised as a cottage industry in the West Coast and in the districts of Tanjore and Trichinopoly. Realising its importance as an auxiliary food during the present times, the Government of Travancore are levying a customs duty of five per cent on banana flour of all grades and varieties exported from that State and have further restricted the export. The Foodstuffs Directorate, New Delhi, are also interested in finding out a source of supply of dried bananas for the use of the defence forces.

Preparation of banana figs by sun-drying has been attempted previously by the Agricultural Department at Aduthurai, Coimbatore and elsewhere, but the quantity produced was small and the popularity of the product was limited owing to its poor keeping quality. Although sun-drying is a simple operation, bananas dried by this method often produce a product which is dirty and mixed with insect eggs. On the other hand, dehydration, by which the moisture is removed by artificial heat in specially prepared chambers, and where temperature and, if possible, humidity and rate of flow of air can be regulated, renders the product free of dust and insect eggs. Furthermore, the risks of damage by rains, storms or cloudy weather are eliminated and a more uniform and superior quality product is claimed by dehydration.

Methods of preparing fig and flour Experiments on the preparation of banana figs and flour dehydration of a large number of varieties were conducted at the Fruit Research Station, Kodur, during 1942-43. The methods employed are briefly described below.

For preparing banana flour, fully matured but slightly unripe bananas were taken and dipped in boiling water for 2 to 3 minutes to facilitate peeling. In some trials, however, ripe fruits were also utilised. After removing the peel by hands, covered with rubber gloves, the pulp was cut into halves or quarters, lengthwise. The slices were then spread on single layers on slat bottom bamboo trays. The trays were then stacked either inside the 'home drier' or in a specially constructed room. The air inside the room or the chamber was heated by means of a charcoal oven or a fire place. By adjusting the ventilators the temperature inside the chamber was maintained at 145°F. to 150°F, while inside the room the temperature ranged from 135°F. to 138°F. When the slices were dry they were removed from the trays, powdered and sifted, and finally stored.

In order to obtain a more attractive and whiter flour, the slices in some of the trials were exposed to the fumes of burning sulphur for 20 minutes before drying.

For the preparation of banana figs the same process as outlined above was adopted except that the slices after dehydration were cut into small pieces and stored as such.

Home drier - its construction and working A small 'home drier' used in these experiments costs about Rs 60 and can easily be constructed by an ordinary village artisan. It is a box (Plate I) 3ft x 1ft. 8in. x 2ft. 6in. resting on a wooden stand 2ft. 6in. high. An iron sheet forms the bottom of the box or chamber.

PLATE I

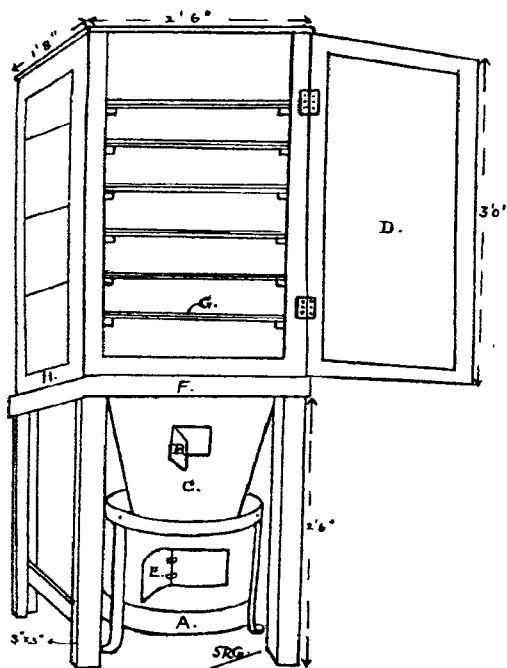

The inside of the door and the portion against which it clings when the chamber is closed are lined with asbestos. The box is provided with two longitudinal openings on the top, each 12 in. long x 1 in. broad for the escape of moisture from inside the box. Another small aperture is provided on the side opposite to the door, to take in a thermometer. The chamber has space for fitting seven trays with bamboo slat bottoms. These trays can be stacked in a staggering manner to allow free circulation of hot air.

The source of heat for the chamber is a charcoal oven which is placed on the ground below the centre of the iron sheet bottom of the chamber. The oven is divided into three sections, the top one for piling up charcoal

and for ignition, the central one with a perforated bottom for stoking and for facilitating the removal of ash through the perforated bottom, and the bottom section for collecting the ash. The central section has got two doors or ventilators provided with collapsible shutters. They permit stoking the fire and help to a certain extent to regulate the intensity of the heat.

The oven is fitted up with a chimney which touches the iron sheet bottom of the chamber. This funnel is provided with two windows opposite to each other, and these are with collapsible metallic doors. These help in feeding the oven with charcoal from time to time and also in regulating the heat to some extent. The temperature inside the chamber can be further regulated by opening or closing the door of the chamber.

The chamber maintains a temperature of 145°F. to 150°F. when fully charged. To ensure uniformity in the rate of dehydration, it is necessary to alter the positions of trays by shifting those at the bottom to the top and vice versa two or three times in the course of dehydration. The drier has a capacity of dehydrating 30 to 40 lb. of pulp at a time.

Dehydration in a room The dehydration room is constructed of bricks and is 8 ft. long, 7 ft. broad, and 8 ft. 6 in. high at the centre. The roof is

Plate I. Home Drier.

A. Charcoal oven, B. Ventilator of the chimney, C. Galvanised iron or tin chimney, D. Door of the dehydrater, E. Ventilator of the oven, F. Stand to mount the dehydrater. G. Wooden tray, H. Body of the dehydrater.

Plate II. Dehydration Room.

made of galvanised iron sheets. The single door is 6 ft. 6 in. x 3 ft. 6 in. and is of ordinary country wood. On each of the two side walls are fitted wooden struts over which the bamboo slat bottomed trays can be stacked in layers with the help of a few bamboo sticks. Opposite the door

PLATE II

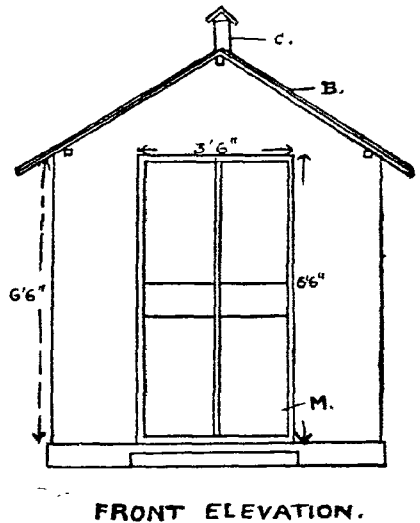
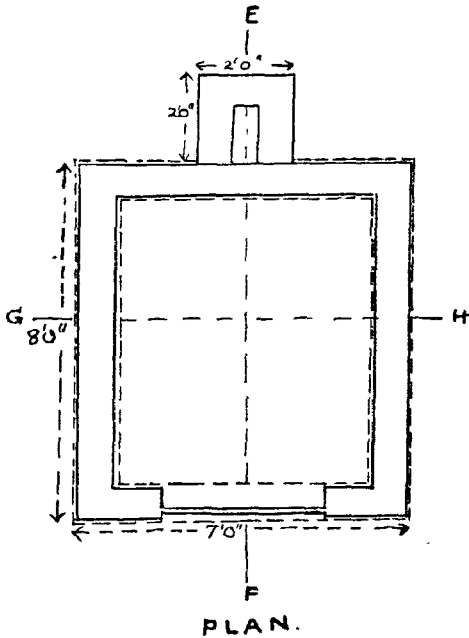
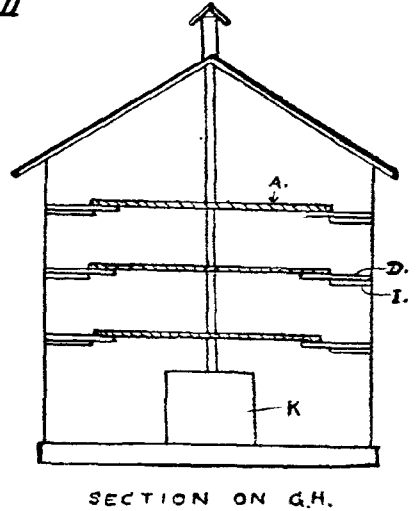
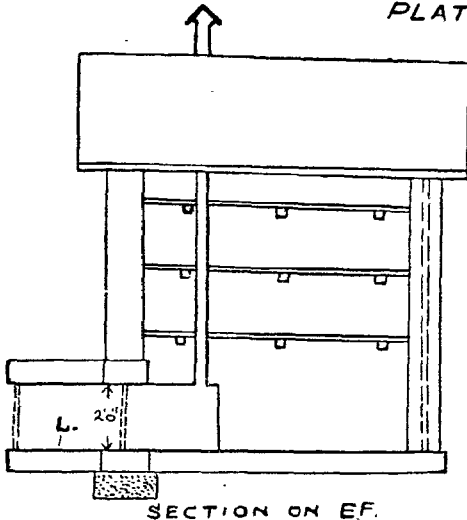

a fire place is built opening to the outside. The fuel consisting of any trash, prunings or dried leaves is ignited through the fire place from outside. The fireplace is closed by a galvanised iron drum from the inside of the room and this serves to radiate the heat. A galvanised iron chimney of

4 in. diameter is built inside the room over the iron drum of the fireplace and rises up above the roof.

When fully charged the room has a temperature range of 135°F. to 138°F. As in the chamber, a slight shifting of the trays is necessary inside the room also to ensure uniformity of dehydration. The room is estimated to cost Rs. 150 to Rs. 200 for construction. It can take about 250 lb pulp at a time.

Tunnel dehydrater Although the above methods were the only ones used at Kodur, it is possible to dehydrate bananas on a large scale with the help of tunnel dehydraters. These are heated by steam or flue pipes and hot air is forced by means of high velocity fans. The quality of the product dehydrated in this manner is stated to be unsurpassed. The short drying time possible in this is a great advantage. It is reported that in West Indies attempts have also been made to prepare flour from banana pulp by means of drums and vacuum driers. At Kodur, however the 'home drier' and the 'dehydration chamber' have been found to be quite suitable for the purpose.

Results of preparation of Banana figs and flour In all 29 varieties of bananas produced at Coimbatore, Anakapalle, Maruteru, Lower Palni, Tellichery and Kodur were utilised for trials on the preparation of banana figs and flour. The trials were conducted at different periods. It was not possible to adopt a uniform standard of fruit maturity at the commencement of each trial in respect of each variety. Both the 'home drier' and the 'dehydration chamber' do not also lend themselves for regulation of temperature with a high degree of precision. The results obtained, therefore, have to be examined in the above background.

Banana figs Exposing the slices to sulphur fumes for about 20 minutes helps to improve the colour of the final product, rendering it more attractive than the figs prepared from unsulphured fruits. Among the varieties tried the best quality fig was obtained from *Pey Kunnan* variety. *Nendrapadathi* and *Ney Poovan* figs were also good. According to the Processed Food Stuffs Directorate, figs of *Kapur* and *Nendran* were not up to the mark as they absorbed moisture in storage. The percentage of recovery as figs on the basis of fresh fruit weight was highest in *Pey Kunnan*, namely 34.7. In the case of *Ney Poovan* it was 32.0 while in the case of *Nendra Padathi* it was only 20.6.

Ripe fruit does not seem to be well suited for the preparation of figs. In general, the product from such fruits even after sulphuring becomes dark in storage. The flavour of fig from *Pey Kunnan* ripe fruits was definitely poor.

Among the varieties tried, *Bontha Ashy*, *Bontha Green* and *Virupakshi* took the least time for dehydration, possibly owing to their solid flesh and low moisture content. At a temperature of 145° to 150°F. these varieties were completely dehydrated in 9 to 10 hours as against 15 to 22 hours taken by other varieties.

Banana flour In the case of flour also, sulphuring the slices gives a far superior product. Flour from ripe fruit is definitely of a better taste and

sweetness than that from unripe fruit. Flour from ripe fruit of *Virupakshi*, *Pey Kunnan* and *Karpura Chakkarakeli* is of a very good quality and is suited for making delicious beverages in no way inferior in flavour to such well-known proprietary products as Ovaltine, etc.

It is, however, much easier to prepare flour from unripe bananas. Such fruits take less period for dehydration and are easily converted into flour after dehydration. Fully mature fruits of certain varieties like *Karpura Chakkarakeli* develop their characteristic ripe peel colour within about an hour of stacking the slices inside the 'dehydration chamber'.

Like the ripe fruits, unripe fruits of *Virupakshi*, *Bontha Green* and *Bontha Ashy* could be dehydrated more quickly than other varieties. *Kareem Kadali*, though it dehydrates quickly cannot be as easily peeled by dipping in warm water as the rest of the bananas.

Wide differences were exhibited by varieties in regard to the percentage of recovery as flour. *Nendran*, in spite of its thick peel produced the highest recovery, namely 27.6 and is, therefore, considered to be most economical for flour manufacture. *Pey Kunnan*, with a recovery of 21.2 per cent, *Bontha Ashy* with 21.6 per cent, *Bontha Green* with 20.4 per cent, *Kareem Kadali* with 21.9 per cent and *Ney Poovan* with 22.8 per cent are other suitable varieties from the above point of view. Varieties which gave low recovery of flour are *Karpura Chakkarakeli*, *Mauritius* and *Pedda pacha arati*, with percentages below 15. The bananas as a whole compare favourably with guavas, in which fruit the recovery of flour was only 12 per cent of the fresh fruit weight.

Banana Figs—Vitamin C values The Director, Nutrition Research, Coonoor, kindly undertook to assay the vitamin C contents of ten samples of figs dehydrated with and without sulphuring. The values are given in Table I.

TABLE I The vitamin C values of banana figs

Serial No.	Variety	Vitamin C—mg. per 100 gm.	
		Sulphured	Non-sulphured
1	<i>Chinali</i>	11.25	12.50
2	<i>Pey Kunnan</i>	15.00	12.50
3	<i>Karpur</i>	12.50	15.00
4	<i>Kunnan</i>	13.75	18.75
5	<i>Nendra Padathi</i>	18.75	16.25
6	<i>Ney Poovan</i>	10.00	7.50
7	<i>Rasthali</i>	11.25	15.00
8	<i>Kali</i>	11.25	10.00
9	<i>Mauritius</i>	13.75	16.25
10	<i>Pedda Pacha Arati</i>	17.50	18.75

It will be observed that the vitamin C content of figs is low. As a source of vitamin C banana figs do not, therefore, seem to be important. The effect of sulphuring seems unimportant. *Nendra Padathi* and *Pedda Pacha Arati* are the two varieties which have shown somewhat higher values of vitamin C than the others.

It may be interesting to compare the above values with those obtained from dehydrated guava flour, data for which are presented below.

TABLE II The vitamin C values of guava flour

Variety	Vitamin C—mg. per 100 gm.
Saharanpur Seedless	310
Allahabad	580
Guava No. 46	490
Smooth Green	280
Red Fleshed	450
Nagpur Seedless	450

Guavas, therefore, are by far a richer source of vitamin C than dehydrated banana figs.

Chemical Analysis Banana Figs The chemical analysis of figs from six varieties of unripe bananas was done at Coimbatore by the Government Agricultural Chemist and the results are given in Table III.

TABLE III Showing the chemical analysis of banana figs

Item No.	Head of analysis	Pey kunnan	Nendra padathi	Karpura chakkara-keli	Kunnan	Ney poovan	Then kunnan
1	Moisture	9.19	9.40	9.63	10.69	7.89	8.94
2	Ash	2.58	3.20	3.03	2.29	2.26	2.18
3	Crude proteins	2.89	3.88	3.68	3.00	2.75	3.22
4	Reducing sugars	49.89	44.20	59.12	52.71	48.12	24.47
5	Non-reducing sugars	4.54	7.12	2.14	4.56	3.01	15.20
6	Carbohydrates, fat, fibre etc. (by difference)	30.91	32.20	22.40	26.75	35.97	45.99
	Total	100.00	100.00	100.00	100.00	100.00	100.00
7	Insoluble matter	0.027	0.061	0.057	0.025	0.056	0.040
8	Lime (CaO)	0.052	0.048	0.055	0.055	0.039	0.045
9	Phosphoric acid (P ₂ O ₅)	0.18	0.21	0.28	0.17	0.18	0.26
10	Nitrogen (N)	0.46	0.62	0.59	0.48	0.44	0.51

According to the Government Agricultural Chemist, the figs are a sustaining food, rich in reducing sugars and other carbohydrates and contain fair quantities of protein and minerals.

Banana flour The results of chemical analysis of banana flour as carried out at Coimbatore and Coonoor are given in Tables IV and V.

In both cases corresponding values for a few other staple foods are also presented for comparison.

TABLE IV Results of analysis done at the Nutrition Research Laboratories, Coonoor—Banana flour

No.	Head of analysis	Karpura chakkara-keli flour from ripe fruit	Bontha Ashy flour from unripe fruit	Mauritius flour from unripe fruit	Arrow root flour (West Indian)	Tapioca	Potato	Goa potato
1	Moisture	9.81	12.42	11.11	16.5	59.4	74.7	74.87
2	Protein	4.58	3.37	4.92	0.2	0.7	1.6	2.46
3	Fat (Ether extractives)	1.72	0.49	0.19	0.1	0.2	0.1	0.21
4	Mineral matter	2.35	1.66	2.61	0.1	1.0	0.6	1.06
5	Carbohydrates	81.54	82.06	81.17	83.1	38.7	22.9	21.40
6	Calcium (Ca)	0.035	0.017	0.017	0.01	0.05	0.01	0.006
7	Phosphorus (P)	0.042	0.019	0.033	0.02	0.04	0.03	0.013
8	Iron (Fe)	4.3	3.0	4.8	1.0	0.9	0.7	1.4
9	Calorific value per 100 gm.	360	346	346	334	159	99	97

TABLE V
Results of analysis done at the Agricultural College and Research Institute, Coimbatore, of flour from unripe fruits

Head of analysis	Karpura chakkarakeli	Bontha Ashy	Mauritius	Pada pacha arati	Nay poovan	Bathes bontha ashy	Bathes bontha green	Bontha green	Nendran	Nalla chakkarakeli	Mala vazhai	Nendra padathi	Kayun kadali	Mean for banana	Rice	Wheat	Potato	Tapioca
Moisture	8.03	8.99	7.25	7.83	7.30	7.46	8.25	7.85	7.83	7.13	7.11	7.73	7.58	—	—	—	—	—
Ash	3.29	2.31	3.45	3.93	2.71	2.92	4.58	2.98	2.98	3.52	3.18	2.91	3.24	3.50	1.02	2.56	4.03	2.06
Crude protein	3.32	3.04	3.49	6.44	2.88	3.47	5.74	3.29	3.15	4.92	3.16	3.72	5.86	4.38	7.73	18.74	9.76	5.00
Crude fibre	1.03	0.95	0.56	0.57	0.59	0.84	2.33	1.15	0.73	0.79	0.85	0.75	0.78	1.00	0.46	1.69	2.74	1.62
Ether extractives	0.81	0.49	0.48	0.69	0.66	0.51	0.76	0.40	0.48	0.59	0.62	0.62	0.53	0.64	0.84	2.69	0.57	0.27
Carbohydrates (by difference)	83.52	84.22	84.77	80.54	85.86	84.80	78.34	84.83	84.33	83.05	85.08	84.27	82.01	90.48	89.95	74.32	82.90	91.05
Insolubles	0.122	0.014	0.039	0.098	0.008	0.057	0.086	0.034	0.020	0.032	0.072	0.079	0.031	—	—	—	—	—
Lime (CaO)	0.062	0.037	0.040	0.046	0.056	0.036	0.090	0.038	0.048	0.041	0.059	0.053	0.038	0.05	0.03	0.13	0.13	0.15
Phosphoric acid (P ₂ O ₅)	0.373	0.218	0.236	0.208	0.225	0.390	0.517	0.382	0.282	0.306	0.240	0.242	0.194	0.33	0.46	1.21	0.54	0.22

The Director, Nutrition Research, Coonoor, has inferred that banana flour both from the ripe and unripe fruit containing as it does some 3.4 to 5.0 per cent of protein, is by no means a poor source of this food factor. Its calorific value is good and it is also not a negligible source of minerals. Further, it contains some vitamin B₁. He, therefore concludes that banana flour is superior to arrowroot flour and also to tapioca, allowing for the difference in moisture content. He suggests that banana flour production should be encouraged particularly as a food for young children. The flour is quite palatable and its sweetish taste would probably appeal to children.*

On the other hand, the Government Agricultural Chemist, Coimbatore infers that the varieties differ with wide limits in nutritive value, flour from unripe *Bathees Bontha Green* being specially mentioned by him as being rich in protein as well as minerals. On comparing the average analysis of 13 varieties of flour from unripe fruits with rice, wheat, potato and tapioca he infers, that banana flour from unripe fruits, though a useful food, cannot stand a comparison with other foods except tapioca, in protein and mineral contents.

In the case of banana figs the reducing as well as total sugars are slightly higher than in the case of flours from the corresponding varieties of bananas. The mineral contents of the flour and figs for any of the varieties analysed are not significantly different.

Although banana flour cannot stand comparison with such staple foods as wheat, rice or potato in its protein and mineral contents, it possesses certain valuable auxiliary food factors such as vitamin B, and vitamin C, and also available iron to a fair degree. It is these factors and not the protein content alone that have led certain authorities to recommend the production of dehydrated banana products as childrens' food. While banana flour may not replace staple food like rice or wheat, it should certainly help as a valuable substitute for the staple foods in times of scarcity. There is no doubt that it deserves popularization in preference to tapioca and arrowroot flours.

In regard to the food value of banana flour a writer in a Jamaican Journal (*The Journal of the Jamaican Agricultural Society, September 1941, page 334*) asserts that it is superior in carbohydrates to wheat flour but inferior in protein or flesh-forming values, very palatable and particularly adapted to persons of weak digestion organs. He refers to cases of patients who were unable to keep down milk or other foods, but easily kept down banana flour made into a thin gruel and flavoured with lemon or lime juice and sweetened with sugar. He adds that the starch in it is particularly easy of solution and digestion in the alkaline juices of the body. Banana meal is also reported by him to be used with safety by persons who do not want to put on flesh but wish to be fit and strong.

* It is being used as food for children in some parts of this province.—Ed.

Use of banana flour and fig Attempts have been made to work out methods of preparing from the banana flour and fig a large number of appetising dishes and beverages. The results of these attempts have disclosed numerous possibilities which remain yet to be fully exploited. A number of recipes which have already been tested are being published in the form of a Departmental Leaflet.

Acknowledgment Sri C. Bhujanga Rao, First Assistant, Fruit Research Station, Kodur, has assisted the author in the conduct of some of the investigations reported in this paper. The Director, Nutrition Research, Coonoor, and the Government Agricultural Chemist, Coimbatore, were responsible for carrying out the vitamin tests and chemical analyses. Dr. G. S. Siddappa, Bio-Chemist, Kodur, has taken the trouble of reading through the manuscript and suggesting improvements in the text. To all these the author's grateful thanks are due.

Effect of Seed Treatments on the Germination of Paddy

By J. C. SAHA

Botany Department, Rajshahi College, Rajshahi (Bengal)

That the cultivation of paddy suffers, often considerably, from the attack of various diseases is well known in India and elsewhere. Attempts are therefore made to prevent or control their damage through various means, viz., through propagation of more resistant varieties, seed treatment, or spraying (or dusting) the standing crop with fungicides. Seed treatment being a cheap and easy method, is within the reach of common cultivators, who, being proverbially poor, are unable to pay for the cost of fungicides and the spraying outfits apart from the question of labour that is necessary to spray large areas. Further, the quantity of fungicide that would be required for seed treatment is infinitesimally small in comparison with the quantity that would be required for spraying fields grown out of the same quantity of seeds. From these considerations agricultural workers are now paying more attention to develop seed treatment as a practical means to combat the diseases. Attempts have, therefore, been made in the present investigation to ascertain whether the chemicals used for treatment have got any detrimental effect on the germination of seeds and, if so, to modify the seed rate in sowing accordingly.

Transplanted *Aman*, var. Chinsura 72, was selected for the purpose. Seed treatments* were done with the following chemicals, that are commonly used in Bengal:—

A—Agrosan G

B—Bordeaux mixture, 1% for 10 minutes

C—Copper sulphate solution, 2% for 30 minutes

D Formalin (aqueous) solution, 2% for 15 minutes

* The seeds were treated 24 hours ahead of sowing and the lots that were treated with liquid fungicides were dried in the sun after the period of treatment was over.

- E—Mercuric chloride solution, 2% for 5 minutes
 F—Potassium permanganate solution, 5% for 15 minutes
 G—Sulphur dust
 H—Water (control)

The experiment was laid out in 15 randomized blocks, each having eight unit plots corresponding to the eight different seed treatments. Only 100 seeds from each treated lot were sown per unit plot. The percentage of germination was calculated on the number of seedlings that come above the soil level. The analysis of variance of the data obtained shows that the seed treatments are significant in their action at 1 per cent level.

Effect of seed treatments on germination of paddy (Summary of results)

	Seed treatments								Standard
	E	A	F	G	H	B	C	D	Error
Average percentage of germination	99.0	98.7	97.6	97.0	97.0	89.3	89.3	87.0	1.34

From the summary of the results given above it will be seen that different treatments have different effects on germination. B (Bordeaux mixture, 1 % for 10 mins.), C (copper sulphate sol., 2 % for 30 mins) and D (formalin—aqueous sol., 2 % for 15 mins.) significantly lower the percentage of germination to the extent of 9 to 10 per cent, while the rest of the treatments have no such inhibitory effect. In fact E (mercuric chloride sol., 2 % for 5 mins.) and A (Agrosan G.) increased the rate of germination by 2 and 1 per cent respectively. But these increases in germination percentage are not statistically significant.

Therefore, when any of the above three chemicals, viz., Bordeaux mixture, copper sulphate solution and formalin are used in seed sterilization the seed rate in sowing should accordingly be increased by 10 per cent.

SELECTED ARTICLES

Improved Breeding for Milk Production

By JOHN HAMMOND, M. A., D. Sc., F. R. S.,

School of Agriculture, Cambridge

In travelling round the countryside to-day one is struck by the vast improvement made in the state of cultivation and in the production of crops during the war. No such improvement has occurred in live stock, however, but most people will probably agree that the time has now come for this to be taken in hand. A widespread movement for the improved breeding of dairy cattle is required, not only for increased production in war time but also to enable the dairy farmer to hold his own successfully after the war. There is every indication that there will be a world shortage of animal products in the immediate post-war years, and we should be prepared to meet this situation. At the present time, and immediately after the war, when supplies of animal feeding stuffs will be difficult to obtain, it is important that the best use should be made of those that are available.

Economy of Production The dairy cow is the most economical animal converter of feeding stuffs into human food. For every 100 parts of protein or starch in the feeding stuffs, the dairy cow produces 20 parts for human food as milk, as compared with only 8 parts as meat by the beef steer. This is one of the reasons for giving the dairy cow priority in the supplies of feeding stuffs.

Individual cows, however vary greatly in their efficiency, and one of our major problems to-day is that of breeding cows with a high efficiency in milk production. High yielding cows are more efficient in the conversion of feeding stuffs into milk than are low yielding cows. The reason for this is that part of the ration of the cow is required for maintenance, that is, to keep the cow alive, before the rest of the ration is used for milk production. A cow producing only 320 gal. per year will use 56 per cent of her ration for maintenance, and only 44 per cent for milk production; on the other hand, a cow producing 850 gal. will use only 35 per cent of her ration for maintenance, but 65 per cent for production. It is obvious, therefore, that by using cows of high productive level we are increasing the economy of production. It is little good to take a lot of trouble in growing oats and other feeding stuffs if we are going to waste them by feeding to low producing cows. The average yield of dairy cows in this country is only about 480 gal. a year, but with improved breeding methods on a large scale there is no reason why it should not be materially increased in the course of a few years.

The practical means by which the improved breeding of dairy cattle can be brought about may be divided into two parts:

- (a) the breeding of dairy bulls which will transmit high milk producing capacity *with a high degree of certainty*;
- (b) the means by which the commercial milk producer can grade up his herd by the use of such bulls.

Let us consider each of these two problems in turn.

Breeding bulls to transmit high milk yields The Dutch breeders have been among the most successful in this sphere, and the secret of the method they use is that of knowing for certain the breeding qualities of the bull before they breed young bulls from him; that is, breeding their young bulls from "progeny tested" bulls only. Here, for example, is a typical pedigree of one of their bulls:

Sire: Athleet x Dam: Gerard Bertha (6 daughters) (7 lact. Av.) (Av. 11,367 lb) (11,235 lb 3.67%)	Sire: Athleet x Dam: Grietje 39,223 (6 daughters) (5 lact. Av.) (Av. 11,367 lb.) (8,922 lb. 3.86%)
Sire: Bertus 16,877 (6 daughters - Av. 11,000 lb)	Dam: Grietje 73,078 (4 lact. Av. - 13,596 lb. 4.6%)
Bertus 19,517	

All the bulls mentioned in this pedigree are 'proven bulls', that is, they are bulls whose daughters had averaged a high level of production. By using a succession of such 'proven bulls' in the herd, it is possible to breed bulls which will transmit high production with a *high degree of certainty*.

Owing to the destruction caused by the war, we shall probably be unable to import more Dutch bulls into the country for some time; we can, however, with great advantage import Dutch methods of breeding for milk and use these methods on all our breeds of dairy cattle.

There is a tendency among some pedigree bull breeders to over stress the value of the dam's production and to pay insufficient attention to the *bull's capability of transmitting milk*. For example suppose one were breeding for red colour in Shorthorns and knew only the colour of the dam and not that of the sire, the chances are that there would be a large number of throw-outs of roans in a herd bred in such a way, even if the cows were selected carefully for red. It is just the same with breeding for milk; you must know the sire's

capacity for milk as well as the dam's if you are to guarantee that the offspring will breed true. It is not enough to say of a bull that his sire's dam had milk, for his sire had a sire as well as a dam, and he may hand down poor milking qualities.

War Agricultural Executive Committees are now establishing registers of approved pedigree and milk recorded herds in their areas for increasing the supply of well bred young bulls for distribution to commercial herds. Provided the sire is well bred for milk there should be no reason why bulls for commercial herds should not be obtained from 'grading-up' cows of high producing capacity.

It is hoped that owners of pedigree, 'grading up' and milk recorded herds will co-operate on these lines in providing a source of supply of bulls for commercial producers. At present a large number of valuable bull calves well bred for milk, are being slaughtered because they are not wanted by other pedigree breeders. The pedigree breeders have not the facilities to rear all their bull calves and to sell them at profitable prices to commercial producers. It is the intention to overcome this difficulty, however either by rearing the bull calves to breeding age on a war Agricultural Executive Committee's farm (if suitable facilities are available) before sale to the commercial dairy farmer, or by supplying week-old bull calves to the commercial dairy farmer to rear for himself. Since some pedigree breeders may hesitate to sell bull calves because bad conditions of rearing may discredit their stock, War Agricultural Executive Committees have been instructed, where necessary, to earmark these bull calves in a distinctive way, and distribute them to commercial dairy farmers without pedigree or the name of the herd from which they originated, records of these being kept in the Committee's files only.

Grading of herds by commercial milk producers While milk recording and the keeping of heifer calves for rearing from the best cows only is a good practice and one to be encouraged, it is slow, because of the limited number of offspring produced by a cow. A bull will produce on the average 35 calves in a year (and with artificial insemination up to 1,000 given great density of cow population), as compared with only one from a cow. Progress can therefore be made much more rapidly by concentrating attention on the bull used. (For the year ended January 1st, 1942 in the whole of the U. S. A. 111,451 cows were artificially inseminated from 408 bulls; in other words 273 cows per bull. Ed.)

Whenever possible, it is better for the herd to rear its own replacements rather than to buy them in, not only because of the knowledge of how the animals are bred, but also because of the danger of introducing disease into the herd through purchased animals.

Dairy cattle should be bred pure or graded up to a pure breed. Cross breeding, except with the definite purpose of continuing 'grading-up' to the new breed introduced, should be strongly discouraged. Unlike the producer of beef cattle, which are all sold off for slaughter, the farmer who breeds cross-bred dairy heifers has to continue to breed from them, and unless the 'grading-up' is continued, a zoological collection of nondescript cows is soon obtained.

In each herd a careful consideration is required of the pure breed to which it should be graded up. In deciding this there are two main considerations: (1) the suitability of the soil, climate and environment of the holding for a particular breed; and (2) the purpose for which the herd is kept. For example, if the owner is a producer-retailer he will probably require a high butter-fat breed with good coloured milk, while if he is rearing and feeding his steer calves he will require a dual purpose type. If beef is the primary consideration, however, it would be better to use a beef bull of distinctive colour markings (Aberdeen Angus-black, or Hereford-white face), so that the heifer calves do not

get on the market under the guise of dairy-bred calves and, when purchased by some other dairy farmer, ruin his output of milk.

In dealing with a low producing herd of nondescript cows, there are some people who would probably say, "Fatten off and slaughter the lot", while, no doubt, a certain amount of weeding out and slaughter of old and diseased cows may with advantage be carried out. In the writer's opinion the present is not the time for the slaughter of even poor dairy stock on a large scale, for there is a shortage of cattle in Europe, and this country needs all the milk that can be produced. Rather, I believe, should we begin immediately to grade up these poor cows by the use of good bulls.

A good herd in two generations The rapidity with which 'grading up' to the high producing pure breed can be effected is probably not fully appreciated by those who have not seen it in practice. A low producing nondescript herd can in two generations be made into a herd of quite reasonably good production and type by 'grading up' with high producing, pure bred bulls. The movement for the better breeding of dairy cattle would be given a great impetus if all dairy cattle breed societies would institute a 'grading-up' herdbook, either with or without entry into their present herd book.

The small herd—one too small to justify keeping a well bred bull—is a problem in many areas. The purchase of bull calves should in most cases solve this problem, although an alternative, and perhaps more convenient and less costly means—by artificial insemination from a well bred dairy bull—is now under trial in the Reading and Cambridge districts.

In conclusion, it is evident that there is a need for the problem of breeding for milk production to be attacked on a broad community basis for the common good of dairy farmers—to prevent bad dairy cattle ever being born rather than merely to accept them as inevitable and push the bad ones off on somebody else, thus lowering the efficiency of the industry as a whole. *J. Min. Agri. Sept. 1943.*

Fruit Bottling

By Miss K. I. NOBLE,

Demonstrator, Ministry of Food, England.

Introduction Fruit bottling not so long ago, was regarded as a typical country occupation, but the war has made the town housewife equally "preserve minded", and, judging from the queries and general interest in this subject, even keener than her country sister who wisely bottles and preserves every year as a matter of course. To be successful, it is necessary to make sure that everything is done to avoid mistakes, and so whatever method is chosen should be followed carefully and the following points noted.

Objects The object of preserving fruit is to destroy bacteria, moulds, yeasts, and enzymes which would otherwise cause deterioration.

Methods The methods of doing this are by (1) sterilizer, (2) oven, (3) pulping, and (4) Campden method.

Water or Syrup Fruit can be bottled very successfully in plain water, although if sugar can be spared flavour is improved by using syrup, viz. ; 2—8 oz. sugar to each pint of water. Preparation of syrup: dissolve sugar in water and boil for a few minutes, strain. Note—syrup with honey: add two parts of water to one part of honey.

Preparation of fruit and jars Fruit should be fresh, dry, sound and firm. It should also be ripe, and whenever possible graded according to size and ripeness. The only exception is gooseberries, which should be bottled when green and hard. Cherries: the dark and red types are best for preserving, e. g., 'Morella'

and 'May Duke'. Apples and pears, when peeled, should be put straight into salt water (1½ oz. salt to 1 gallon water) to prevent discoloration, but not left long before being sterilized.* They could alternatively be (a) steamed for five minutes, or (b) blanched for three minutes. Currants, black, red or white: stalks should be removed, also blossom ends if very large, and then rinsed in cold water. Soft fruit are hulled and shaken well down in the bottles. Raspberries in syrup are fruit which are inclined to rise; to overcome this fill bottle 1/3rd full of fruit, then cover with liquid and continue alternatively until bottle is full. Stone fruit, e. g., cherries and plums: pack tightly without crushing, using the handle of a wooden spoon, to the top of the jar. Jars or bottles must be washed and rinsed, also examined carefully for flaws or other damage, particularly round lip. Wash and thoroughly dry lids and rubber bands; the latter should be carefully examined and discarded if they show signs of perishing; they should fit easily and, if in good condition, go back to their original size when gently stretched.

Sterilizing under water Soak rubber rings in warm water before use. If no special sterilizer is available, use a large deep saucepan, fish kettle, boiler or pail. The receptacle should be deep enough for water to cover the jars when they are placed on a wire or wooden rack, or on several thicknesses of cloth or paper (to guard them from direct heat). If it is not possible to cover the jars completely, the water should reach well up to the shoulders. Cover the receptacle to prevent evaporation. Any of the following jars are suitable for this method: (1) bottling jar with glass top, rubber ring and metal screw band (2) bottling jar with metal top, rubber ring and clip; (3) standard 1 lb. or 2 lb. jam jar with rubber ring, lid closure and clip. **METHOD:** (1) Prepare fruit as described and pack into jar. (2) Fill to top with fresh cold water or syrup if used. (3) Screw top jar—Place rubber ring and glass top in position and screw down metal closure. Now unscrew by one half turn so that it is loosely closed but will allow steam to escape. Clip top jar—Place rubber ring and metal top in position on jar and secure with clip. Standard jam jar, with metal closure—Fit with rubber ring on to sloping edge of lid. Place this on jar and slide the clip on so that it holds firmly in position. The clips, being pliable, should be bent at a more acute angle if necessary to grip well. (4) Place the jars in sterilizer or receptacle, fill with cold water and cover with lid. (5) Heat slowly until temperature reaches 165°F, taking 1½ hours to do so (if no thermometer is available, heat to a slow simmering temperature), and maintain this heat for 10–20 minutes—degree of heat and time maintained depends on the type of fruit. The following Ministry of Agriculture table is a good guide (Leaflet No. 11, Dig for Victory).

			Temperature to be reached in 1½ hours (in degrees F.)	Maintain for (Minutes)
Apples (solid pack)	175	10
Apples (in syrup), Apricots, Blackberries, Damsons, Gooseberries, Greengages, Loganberries, Mulberries, Peaches, Plums (ripe whole), Raspberries, Rhubarb, Strawberries	165	10
Plums (halved or unripe)	165	20
Currants	180	15
Pears	190	20
Cherries	190	10
Quinces	190	20
Tomatoes	190	30

(6) After sterilization remove jars, place on wooden board or table and (a) tighten

* Pears—Only ripe dessert pears should be treated in the manner described here. Cooking pears should be stewed until tender before bottling.

screw band immediately, and again after a few minutes, then leave till the next day; (b) leave clip top bottles as closing action with these is automatic.

Testing the seal Remove the screw band or clip and lift the bottles by the lids. If seal is perfect, lids will remain in position. If lid comes off, the seal is imperfect and fruit should be re-sterilized, if necessary in another jar as imperfections are often responsible for imperfect sterilization, or it can be used quickly.

Oven method This method is popular because it is quick and simple and, if fruit shrinks to any extent, one jar can easily be filled up from another, replacing in the oven for a further five minutes to complete sterilization. The main points are (1) Prepare fruit and pack as for sterilizer method. (2) Do not add water or liquid. (3) Cover each jar with glass top, patty pan or other lid to prevent top fruit from being overheated. Do not put on the rubber rings in oven, or clips or screw bands. (4) Place on asbestos mats or baking sheet in a slow oven (250°F or Regulo $\frac{1}{2}$ -1) and heat until the fruit appears cooked and juice begins to run ($\frac{3}{4}$ to 1 hour—tomatoes $1\frac{1}{2}$ hours). (5) Fill up jars if necessary and replace in oven for 5-10 minutes. (6) Have ready fast boiling water or syrup. Remove one jar at a time from the oven, place on a wooden board or table, fill to overflowing with boiling liquid and cover immediately. Tighten screw if possible again as the jar cools. Test the seal the next day as in sterilizing method.

Pulping Pulping is a useful method when fruit is plentiful; rather over ripe fruit may be used. If storage space is limited, this way can be used and the pulp later made into jam or used for puddings. Fruit is stewed with very little water (tomatoes do not require any, but allow $\frac{1}{4}$ oz salt to every 2 lb.). When cooked, and while still boiling hot, pour at once into hot sterilized jars, seal immediately as when bottling and sterilize by placing in a pan of hot water (standing them on a fake bottom) and boil for five minutes. Tomato pulp requires fifteen minutes sterilization. Note—If fruit is sieved (in which case tomatoes and apples, for example, need only be washed and cut up before stewing), the puree must be brought to the boil before pouring into hot jars and sterilized as above.

Campden method The Campden method is quite easy but is not recommended for gooseberries or currants as it tends to toughen the skins. Neither is it suitable for sweet fruits such as sweet cherries, dessert apples, pears, tomatoes and black berries. It should never be used for vegetables. The main points are (a) choose sound fruit (b) to each 1 lb. of fruit allow at least $\frac{1}{2}$ pint of the solution (i.e., 1 Campden tablet crushed and dissolved in $\frac{1}{2}$ pint tepid water), (c) the fruit must be completely covered with the solution, (d) the jars must be made airtight; metal tops should be protected with wax or greaseproof paper to prevent sulphur coming into contact with the metal. The fruit loses most of its colour but most of it should return on cooking. Before eating the fruit, it and the liquid, should be put in an open pan and stewed gently to drive off sulphur fumes for about 20-30 minutes, or until no taste of sulphur remains; then sweeten to taste and use as required for pies, stewed fruit, etc. Plums, rhubarb and cooking apples are particularly suitable for preserving this way.

Tomatoes Tomatoes may be sterilized in a sterilizer, or in the oven. They are very good if preserved in their own juice. Tomatoes should be skinned, halved or quartered and packed tightly into bottles with a sprinkling of salt and sugar between the layers, allowing $\frac{1}{4}$ oz. salt and $\frac{1}{4}$ oz. sugar to each 2 lb. Tomatoes. Sterilize as for fruit but bring temperature up to 190°F. in $1\frac{1}{2}$ hours and maintain for 30 minutes.

Storage Bottled fruit should be stored in cool, dry, dark place whenever possible. Metal screw bands should be lightly greased with vaseline on the inside and lightly screwed back on the jars. It is advisable to look over one's store from time to time so that any sign of mould or deterioration is detected in its first stages. *J. Roy. Hort. Soc.; Sept. 1943.*

Abstracts

Milking three times a day (*J. Min. Agri. Sept. 1943*) Three times a day milking has often been practised with high yielding cows to obtain exceptionally high yields from a few cows. This practice is extended to obtain an increased yield from all the very ordinary members of a commercial herd. It is known that under natural conditions, with the cow suckling a calf, secretion of milk is stimulated as the appetite of the calf increases, since the udder is sucked dry. By twice a day milking the udder is emptied only twice each day and there are long periods when the udder is relatively full of milk. By three times a day milking, the more frequent empty condition of the udder should stimulate secretion; and in consequence, a greater development of the milk producing tissue and an increased blood supply to the udder should result. If these conditions are obtained during the first lactation, it seems reasonable to expect that the cow would be a more capable producer during succeeding lactations.

The cows are managed well giving them a two month dry period to calve down in good condition. Calves are weaned at birth and the cows milked twice daily for three days and thrice daily thereafter at 5-30 a. m., 1-30 p. m., and 7-30 p. m. This three times milking is continued for six months, that is two thirds of the lactation period. If the cow has not been effectively served by then thrice milking can be continued. There is a fall in milk yield when twice milking is resumed. The cow is eventually dried to develop the embryo and build up her body for the next calving.

Mr. Arthur Amos of Kent, England, who suggests the effectiveness of milking three times a day has a herd of a few cows which averaged only 600 to 750 gallons milk per lactation in 1936. In 1942 the herd averaged 943 gallons of milk by thrice milking. The most outstanding performance was that of a cross bred Fresian Shorthorn, Blue III, which gave only 700 gallons during her first four lactations on the twice a day system. As soon as she was milked three times a day, production jumped to 1435 gallons in the fifth lactation. In her sixth lactation she gave 1800 gallons and her seventh lactation produced 1548 gallons. High yields in the first lactation are followed by increased yields during the subsequent lactations, provided they are properly fed and managed.

Thrice milked cows were regular in breeding and free from disease. The more frequent removal of milk from the udders naturally kept them in good shape. The trial has not been conducted under strictly experimental conditions and the author suggests further studies.

A. H. S.

Gleanings

Dehydrated foods for beasts—Dried grass Although the war has stimulated the production of dried grass for cattle food, grass driers have, in fact, been in a process of evolution during the past ten years. * * Some interesting data dealing with grass drying have been given by George G. Pollitt in an article in the book *Britain can Feed Herself*. He states that the advantage of artificially drying grass over making the same grass into silage is that with drying there is practically no loss, whereas in making silage there must always be some loss, in normal circumstances amounting to 20% of the dry matter. Silage when properly made, is an excellent food, and will replace a balanced concentrated food, but whereas the grass from an acre, when artificially dried, will replace at least 2 tons of a concentrated feed properly balanced for milk production; it will only replace 1½ tons when made into silage. Several reasons for drying grass instead of making into hay are given. However good the weather and however well the

hay is made the losses, some mechanical and some due to chemical action, may amount to 50% in a normal season. It is pointed out that when grass is artificially dried it can be cut and conserved immediately it has reached the desired state of growth. When so cut, the yield of protein and the feeding value throughout the season is greater than when the grass is allowed to reach the hay stage. *J. Min. Agri Aug 1943.*

Manufacture of absorbent cotton wool Ordinary raw cotton, as it comes from the ginnery, will not readily absorb water, because mature cotton hairs are covered with a thin coating of wax, which renders them more or less water-proof. If the cotton is boiled in an alkaline solution, the wax becomes saponified, that is it is, converted into a soap which can be washed out, leaving the hairs free of wax, and thus able to absorb liquid

* * * * *

The production of absorbent cotton can be divided into three parts—(1) opening and cleaning, (2) wet processing, (3) finishing or dry processing.

Before the raw cotton is wet processed it is cleaned, and thoroughly opened (fluffed out), and all dust and dirt extracted. To do this the "blow room" machinery in the spinning mill is used. This consists of a series of machines which open, and tease out the lint and subject it to treatment by powerful dust extracting fans.

Wet processing The clean lint is boiled in what is known as a kier boiler, which consists of an empty boiler shell, to which steam pipes, for heating, are attached

The raw cotton, about eight hundred pounds at a time, is packed into the kier boiler and the door fastened down by means of heavy screws bolted to the circumference. An alkaline solution is then pumped into the boiler, and gradually raised to boiling point under a steam pressure of 30 lb. This boiling process is continued for a period of eight hours, then the alkaline liquor is run off and replaced by clean soft water. This in turn is replaced by a second supply of water in order to wash out any remaining traces of alkali. The door of the kier is opened, and the boiled cotton extracted and placed in cement vats, where it is bleached with a specially prepared bleaching solution. This solution is subsequently drained off and the moist cotton washed with a further supply of soft water. The cotton is next steeped in what is known as a "souring" bath, consisting of a weak acid to neutralise any alkalinity that may be retained from the previous processes.

After two further washings with fresh water the cotton is squeezed between rollers to get rid of most of the surplus water and then spread out to dry on racks made of small mesh wire netting.

While drying the cotton undergoes natural bleaching and gives the finished commodity its bright white appearance.

Dry processing When the cotton is thoroughly dry it is packed in new clean woolpacks and transferred to the spinning mill, where it again undergoes treatment in the blow room before it goes to the carding engines.

Here the cotton is passed between a large revolving drum covered with very fine, closely set, wire spikes and a series of smaller rollers, similarly covered, but rotating in the opposite direction. The effect on the cotton passing between these rollers is that the individual hairs become separated, drawn out to a certain extent, and parallelised. As the now carded cotton comes from the carding machines it is combed by a rapidly oscillating fine tooth comb, which delivers the cotton in a particularly flimsy, almost transparent, web, on to a large revolving drum

From this drum the cotton is transferred to the rolling and interleaving machine, which rolls, compresses and wraps the cotton in the outer paper covering. *Rhod. Agri. J. Vol. XV, No. 4.*

'**Plowless Farming**' "During the last twelve years we have worn out only one plow point. Most of that wear was in the three gardens and in some contour plowing in the pastures. Since giving up 'Farming' we have cut our overhead expenses over 50 per cent and have eliminated all the gullies and galls that had earned for our place the reputation of being the poorest farm in the country. It is years since we have bought any hay. Our purchases of high protein feeds have been cut in half. Our cattle are bigger and they produce 40 per cent more milk with 40 per cent less labour".

Mr. Arnold. G. Ingham, a farmer from Virginia in U. S. A. achieved this feat. He was growing corn for a number of years and found in 1930 that after every crop of corn the field was a mass of gullies 2 to 10 inches deep. It did not require an expert to figure for him that more plant food was washed away than had been taken up by the corn crop. It takes nature 400 years to make one inch of top soil and his had been washing away for over a hundred years, he had farmed by overdrawing on the 'Bank of Fertility'.

It was figured that if that land had been in a good stand of grass there would have been little or no soil erosion. Accordingly he planted a lot of pasture grass and clover seeds. He heard of people who had gone in for pasture fertilisation and had cut down the cost of producing milk and raising cattle. The Dept. of Agriculture showed that the average dairy farmer spent fifty times as much for feed as he did for lime and fertiliser, but that the most successful dairy farms spent nearly half as much for fertiliser as they did for feed. They also showed that cows on grass produced better and cheaper milk than cows fed in the barn. They also showed that young cattle raised on good pasture grew bigger and healthier and are much cheaper than young cattle raised on hay and grain.

In the last 7 years Mr. Ingham used over 1000 tons of lime and 200 tons of fertiliser on 140 acres of grass land. His entire herd is living on hay. He has the best alfalfa crop. His gross income per cow was \$ 300, a year. He also saved his land by '**FLOWLESS FARMING**'. *Soil Conservation, August 1943.*

For washing milk separators Milk separators require careful attention. If they are left unwashed, enormous numbers of bacteria grow in the residue in the bowl and other parts and are picked up by the cream at next separation. This is one of the chief reasons for poor quality cream. For best results the separator must be thoroughly washed and scalded after each run. If for any reason this is not done, the keeping quality of the cream may be improved by the following treatment; with the bowl turning at full speed, pour a pialful of hydrochlorite solution into the supply tank. Brush the inside of the tank with this solution, then allow it to run through the machine. This will rinse out and destroy many bacteria and prevent them contaminating the cream when the milk is run through the machine—*Dept. of Agriculture, Canada. Indian Farming, May 1943.*

New committees for tobacco, sugar, rice and coconuts Tentative decisions have been reached to set up four new committees, on the model of the Central Jute or Central Cotton Committee, which will deal with tobacco, coconuts, rice and sugar. The necessary legislation will shortly be undertaken to implement the decision. The Central committees on Rice and Coconuts will be financed by levy of a small cess, while the other two committees will be financed by contributions from the Sugar and Tobacco Excise Duties.

The proposal to set up a Coconut Committee has already been approved by the Governments of Madras, Mysore and Travancore, and negotiations are at present in progress to bring in Cochin before the legislation is undertaken.

Similarly the proposal to set up a Rice Committee is under discussion with the Provincial Governments. It envisages the levy of a small cess of say one

pice a maund on milled rice. This is expected to yield Rs. 30 lakhs a year. In view of the urgency of the problem the Committee might be set up by ordinance. The Sugar and Tobacco Committees will be set up by a resolution of the Government of India.

As for tobacco Rs. 10 lakhs have been provided from the Tobacco Excise Duty and it is now proposed to establish a Central tobacco station at Guntur to study fundamental problems connected with tobacco. Mr. Cocks has been appointed Tobacco Adviser to the Government of India. There will be four experimental stations for cigarettes (Virginia), *hukka*, *bidi* and cigar tobaccos. These stations will be located at Guntur Puri, Anand (Guzerat) and Trichinopoly respectively. There will be twenty sub-stations in tobacco producing provinces, such as Bengal, United Provinces, Punjab Bombay and in the West Godaveri District of Madras. On the development side a staff will be employed to encourage cultivators to introduce improved strains of tobacco, to organise growers' co-operative societies, to enable them to own their curing barns and warehouses.

The Mxrl, December 11, 1943

Research Notes

Three new insect pests in the Madras Presidency

This year is rather notable in the fact that three insect pests which are not known to be present previously in this Presidency have made their appearance in quick succession. They are (i) the granary weevil—*Ceolandra granaria*, (ii) the San Jose scale—*Quadraspidiotus perniciosus* and (iii) Khapra beetle—*Trogoderma Khapra*.

The granary weevil which is closely allied to the rice weevil—*C. oryzae*—is a well known pest of wheat in storage and is known to thrive best in temperate climate. In India it is known to occur in the Punjab in small numbers. This was first noticed in Madras in the wheat stocks from Australia in May, 1943.

The San Jose scale is a notorious pest of fruit trees such as apples, plums, citrus, pears etc. in different parts of the world. This is known to be present in the Punjab, United Provinces, North West Frontier Provinces and Kashmir. More recently it was noticed infesting apple seedlings in Coonoor.

The Khapra beetle is a well known pest of wheat, pulses and maize in the Punjab, the United Provinces, etc. This has come to be noticed in November in appreciable numbers in Bengal gram stocks recently imported into Madras from North India. The infestation of this pest was more pronounced in grams severely affected with the pulse beetle—*Bruchus analis*.

Agricultural Research Institute, }
Coimbatore, 1st December 1943 }

M. C. Cherian,
Govt. Entomologist

Correspondence

To

The Editor, Madras Agricultural Journal.

Sir,

In a letter to the Editor, *Science and Culture*, written by T. Hussain, R. C. Guha and B. Mukerje, and published in Vol. IX, No. 4, October 1943 page 167, under the heading, *Polygala chinensis* Linn. as substitute for 'official' senega, the authors state, after giving details of the results of the analysis of the respective roots of *Polygala chinensis* and *Polygala senega* and of their respective tinctures, that Tincture senega from *P. chinensis* has now been in use in several Governmental hospitals and dispensaries for more than six months as an important constituent of 'stimulant expectorant' mixtures, and physicians have not had any evidence of its lack of efficacy as compared to Tinct. senega from *P. senegal*. The authors

add that this is an indirect evidence that the change of the species is not of much therapeutic significance and that with slight modification in chemical standards, *P. chinensis* may therefore be included in the B. P. and B. P. C. and Indian manufacturers need not depend on imported *P. senega*. It might interest the readers to note that this valuable medicinal plant, *P. chinenses*, is found very commonly throughout the Madras Province, in all dry districts, from the plains to 3,000 ft. In Coimbatore it is a very common weed in black soil. In this connection, it may be mentioned that Coimbatore is fairly rich in a number of other medicinal plants also for which there is a great demand.

Agricultural College &
Research Institute }
Lawley Road P. O. Coimbatore. }

S. N. Chandrasekharan,
Lecturer in Botany

Sir,

The use of Tamarind seed as cattle feed

The use of tamarind seeds as sizing material for cotton yarn and the discovery of a very rich source of pectin in the seeds have been published in a recent issue of the *Madras Agricultural Journal*. The seeds have been used as sizing material for local blankets from time immemorial. The demand from this source was not, however considerable. But the seeds have considerable demand as cattle feed. Chiefly milk buffaloes, goats and pigs and even work bullocks are fed with roasted and soaked seeds. As a result the price, which was 4 to 8 annas per palla (100 seers), rose to one to three rupees, and this year the seeds were in demand at Rs. 7 per palla!

The seeds are roasted on a large pan about 18 in. x 30 in. in size (made of kerosene tin material) having a number of perforations. While still hot, cold water is sprinkled on the seeds to facilitate the removal of the seed coat. They are then pounded to remove the husk, cleaned and stored. Before feeding, their seeds are soaked preferably in hot water for 24 hours. 100 seers of raw seeds give about 60 seers of roasted seeds and the cost of roasting and cleaning comes to a rupee. The roasted seeds were sold and purchased at Rs. 14 per palla this year when food stuffs like *ragi* were sold at Rs. 20.

Usually 2 to 3 seers are given to milk buffaloes. Larger quantities might cause digestive troubles. In the taluks of Kalyandurg, Madakasira and Hindupur and the adjoining taluks of the Mysore state, the seeds are largely fed to cattle.

Whether the tamarind seeds can be classed with concentrates like cotton seed, dholl husk etc., is a matter for investigation.

Pothaganahalli, Tumkur Dt. }
7-11-1943 }

P. Rama Rao

[The roasted tamarind kernels contain 16.12 per cent of crude proteins, 6.32 per cent of fats, and 61.47 per cent of carbohydrates and are fairly good feed for cattle.—*Ed. M. A. J*]

Review

“*Cryptostegia Grandiflora* R. Br.—A war time source of vegetable rubber”—By B. Viswa Nath—*Journal of Scientific and Industrial Research*, 1943, pp. 335—383. The article describes briefly the more important results so far obtained from the co-ordinated and co-operative investigations on *Cryptostegia grandiflora* by the Imperial Agricultural Research Institute, New Delhi, under the direction of the author. The results of these investigations have enabled definite recommendations to be made, of methods for quick and large scale propagation of the plant and for the extraction of rubber from it. Although *cryptostegia* latex is poorer than that of *Hovea cryptostegia* rubber could be utilised even for high grade mechanical rubber if all the processes involved from coagulation to smoking were carefully controlled.

Cryptostegia grandiflora is a large woody shrub with conspicuous pale purplish funnel shaped flowers and characteristic whip-like branches which twine and climb over fairly tall trees. It is latescent throughout, the stem, leaves and fruits exuding a milky latex when cut. In India it has been found growing throughout the length and breadth of the country and appears to be remarkably adaptable to wide variations in environment.

The plant can be propagated easily both by stem cuttings and by seed. Propagation by seed is to be preferred to propagation by cuttings for obtaining quick results. Seeds are produced in fair abundance and are highly viable. Seedlings may be raised in the nurseries and transplanted or the seeds may be directly sown in the field according to circumstances of locality and weather. Presoaking of seed in water eliminates light, nonviable and damaged seeds by floating and secures larger, quicker and more uniform germination. Raising of nurseries and transplantation of seedlings is ordinarily to be preferred to broadcasting the seed. Seed rates for nursery and field planting have been worked out and methods of raising nurseries and transplanting have been recommended.

The latex cells in the plant are distributed throughout the tissues and for this reason tapping for latex is best done by clipping of the branches of suitable size and collecting the latex that drips. Tapping during the latter part of the day gives larger yields than tapping during the early part of the day. In regard to frequency, tapping once in three days is more economical than alternate day and daily tapping from the points of view of the health of the plant, economy in labour and cost. It is not advantageous to tap during the defoliation period. "Plug", the small ball of rubber that collects at the cut-end after the dripping of the latex has ceased, forms a very important source of rubber and its yield in hot months is even greater than that of rubber from latex. A point of considerable and immediate practical interest that emerges from this observation is that, if and where necessary the collection of latex can be omitted but the plants can be clipped as for tapping and the plugs collected. This method of plug collection may be employed for dealing immediately with the existing wild growth of *Cryptostegia* in different parts of the country.

A method of water coagulation for latex has been evolved. An addition of twenty volumes of water brought about coagulation of the latex. But when the latex is diluted with water warmed to 80 to 90 C, the dilution required is reduced to six to eight volumes to bring about coagulation. This method has the advantage of simplicity and cheapness.

Tapping for latex is an expensive item in the production of rubber from *Cryptostegia grandiflora* and requires a large force and equipment. The cost of producing rubber from this plant is not mentioned. It would have been better if this had been worked out and given so that the enthusiastic public may be induced to grow this as a short term rubber crop. Nevertheless this timely publication, when there is an all out effort by the United Nations to increase the output of rubber to meet the shortage resulting by the occupation of the rubber producing countries, like Malaya and Dutch East Indies, by the Japanese, will be of immense value.

I. V. R.

Crop and Trade Reports

Paddy—1943-44—Second forecast report The average area under paddy in the Madras Province during the five years ending 1941-42 represents 13.3 per cent of the total area under paddy in India. The area sown with paddy up to 25th November 1943 is estimated at 9,523,000 acres. When compared with the area of 9,149,000 acres estimated for the corresponding period of the previous year, it reveals an increase of 4.1 per cent.

An increase in area is estimated in all the districts of the Province except in Kurnool, Anantapur, Chingleput, Salem, Coimbatore, Trichinopoly, Tanjore and

Ramnad. The increase in acreage is due partly to timely rains at the time of sowing and partly to the propaganda to grow more food crops. The variations are marked in East Godavari (+110,000 acres), West Godavari (+70,000 acres), Kistna (+72,000 acres), Chingleput (-97,000 acres), Chittoor (+110,000 acres), North Arcot (+75,000 acres) and Tinnevely (+65,000 acres). The first crop of paddy is being harvested in parts of the province. The yield per acre is expected to be normal in West Godavari, Kurnool, Bellary, Cuddapah, Nellore, Chittoor, North Arcot, Salem, Ramnad, Tinnevely and the Nilgiris and slightly below the normal in the other districts of the province. The seasonal factor for the Province as a whole works out to 96 per cent of the average as against 91 per cent in the corresponding period of the previous year. On this basis, the total yield is estimated at 92 730,000 cwts of cleaned rice as against 83 760,000 cwts, estimated for the corresponding period of the previous year, representing an increase of 10.7 per cent.

The wholesale price of paddy, second sort, per imperial maund as reported from important markets on 11th December 1943 was, Rs 8-4-0 in Mangalore, Rs. 7-15-0 in Madura, Rs 6-8-0 in Vellore, Rs 6-7-0 in Rajahmundry, Rs. 6-5-0 in Guntur, Rs. 6-3-0 in Ellore and Masulipatam, Rs 6-0-0 in Tinnevely, Rs. 5-15-0 in Cocanada and Bezwada, Rs. 5-12-0 in Trichinopoly, Rs 5-3-0 in Chittoor, Rs 4-15-0 in Kumbakonam Rs. 4-14-0 in Negapatam, Rs. 4-5-0 in Conjeevaram and Rs. 4-4-0 in Cuddalore. When compared with the prices published in the last report, i. e., those which prevailed on 6th November 1943, the prices reveal a rise of approximately 18 per cent in Rajahmundry, 10 per cent in Trichinopoly, 9 per cent in Mangalore, 6 per cent in Conjeevaram, 3 per cent in Cuddalore, 2 per cent in Cocanada and Guntur and 1 per cent in Masulipatam and a fall of approximately 3 per cent in Madura, and 2 per cent in Bezwada, the prices remaining stationary in Ellore, Vellore, Kumbakonam, Negapatam, and Tinnevely.

Sugarcane 1943 - Intermediate forecast report The condition of the sugarcane crop is generally satisfactory outside Vizagapatam, where the crop is reported to have been damaged by cyclonic winds in parts of the district and Kistna where the crop is reported to have arrowed profusely. The yield per acre is expected to be normal except in the above two districts.

The wholesale price of jaggery per imperial maund as reported from important markets on 4th December 1943 was Rs. 15-13-0 in Erode, Rs. 13-15-0 in Coimbatore and Mangalore, Rs. 13-12-0 in Adoni, Rs. 13-5-0 in Cuddalore, Rs. 13-3-0 in Rajahmundry, Rs. 13-0-0 in Ballary, Rs. 12-3-0 in Cocanada and Salem, Rs. 12-0-0 in Chittoor, Rs. 11-0-0 in Vizianagram and Vizagapatam, Rs. 10-9-0 in Trichinopoly and Rs 9-8-0 in Vellore. When compared with the prices published in the last report, i. e., those which prevailed on 6th November 1943, these prices reveal a rise of approximately 12 per cent in Adoni, 9 per cent in Vizianagram and Bellary, 6 per cent in Trichinopoly and 4 per cent in Cuddalore and a fall of approximately 19 per cent in Vizagapatam and 5 per cent in Salem; the prices remaining stationary in Cocanada, Rajahmundry, Chittoor, Vellore, Erode and Mangalore. (*From the Commissioner of Civil Supplies, Madras*)

Cotton, Raw, in the Madras Province The receipts of loose cotton at presses and spinning mills in the Madras Province from 1st February to 19th November 1943 amounted to 84,793 bales of 400 lb, lint as against an estimate of 406 300 bales of the total crop of 1942-43. The receipts in the corresponding period of the previous year were 670,458 bales. A total quantity of 580 352 bales mainly of pressed cotton was received at spinning mills and 3,470 bales were exported by sea while 232 260 bales were imported by sea mainly from Karachi and Bombay. (*From the Director of Agriculture, Madras*)

Mofussil News

Late V. Karunakaran Nair, B Sc (Ag) Sri V. Karunakaran Nair as Agricultural Demonstrator, Sivaganga for a short period of about two years, endeared himself not only to the *ryot* population of Sivaganga but to the public at large, by his devotion to duty, solicitude to the welfare of the poor *ryot*, and his amiable disposition, tact and ability to satisfy the intelligentsia, who are generally the critics of our work. He could win the affection of the public so much that on hearing of his sudden demise due to typhoid they resolved to present a portrait of his, to the Agricultural Demonstrator's Office, Sivaganga. The Director of Agriculture was pleased to accord the necessary permission. The portrait was unveiled by Sri G. Damodara Rao, B.A., B.L., District Munsiff in the presence of a large gathering of the elite of the town. The president paid a touching tribute to the departed soul before he unveiled the portrait. The District Agricultural Officer, Ramnad, thanked the public and formally accepted the portrait on behalf of the Department and put it up in a prominent place in the office.

K. N. D.

Exhibition at Ramnad An Agricultural exhibition was held from 5th to 9th November 1943 in connection with the birth-day celebration of the Sethupathi Raja Sahib of Ramnad. The show was put up in the tastefully decorated frontage of the Paliampatti Zamindar's bungalow; Grow More Food posters and placards were given a prominent place in the get up. Improved strains of paddy, *chotam ragi* and *cumbu*, specimens of *kolungi*, *dhaincha*, sunnhemp, fodder crops, potatoes, vegetables and fruits, and seedlings of economic trees like *vagai*, *vembu*, casuarina and *Glyricidia maculata* were on show. The vitamin value of food stuffs, especially of green leafy vegetables and home pounded rice with practical demonstration with 'Annapurani' hand rice sheller were a special feature. The plant pathology posters and specimens, sprayers and chemicals were also exhibited. The implements and apiculture, with practical demonstrations were very much appreciated. The 'Ryots' Day and 'Students' Day were specially crowded. The exhibition has served its purpose splendidly well in this backward tract.

M. P. S. N.

Agricultural Exhibition at Tiruvannamalai An agricultural exhibition was held at Tiruvannamalai from 1st to 10th December 1943, during the Karthigai Deepam festival. This is one of the major exhibitions in the North Arcot District where nearly a lakh of people come to the festival. A special feature of the exhibition was the impetus given to the Grow More Food campaign offering prizes to those who paid special attention to the cultivation of vegetables. The grant of Rs 15 kindly granted by the Collector of the North Arcot District was utilised for awarding prizes to some of the vegetable exhibits. A pumpkin weighing 63 lb. an amaranthus plant of over 15 ft. in height, a drumstick and ribbed gourd, nearly 3 ft. long, a chilli plant (Guntur strain No. 498) having a viss (3 lb.) of green chillies in one plant, big sized beans, brinjals etc., were some of the exhibits. The Fruit Specialist, the Curator, Botanic Gardens, Ootacamund, the Millet, Paddy and Oil Seed Specialists and the Agricultural Chemist sent interesting exhibits. Locally prepared biscuits, cakes, bun and bread from *ragi* flour attracted the attention of the visitors and over 10 000 *ryots* visited the stall nearly 400 packets of vegetable seeds were sold on the spot and the demand could not be completely met with.

M. A. B.

Madura District—An Ideal Farmer Mr. W. P. A. Soundara Pandia Nadar, a large land holder of Pattiveeranpatti village, Nilakottai Taluk, Madura District, is a practical farmer even though he is very busy in public affairs having been elected recently as the president of the District Board. He takes particular pride in contributing to the increase of food production in his lands.

In a block of 100 acres under a tank which receives its supply from the seasonal rains, only one crop of paddy used to be raised. But during the past year he proceeded with a determination to produce at least two crops. He did succeed. But he did not stop there. Due to a lucky shower in the summer, a small supply of water had accumulated in a tank, and he sowed a short duration paddy in 36 acres. The crop grew well but it was feared that the water supply would run short and the crop would fail. He managed to get the required fuel, which is difficult to get now and worked an oil engine and pump for baling water from a big well in his lands and succeeded in getting the crop to maturity. The yields of food grains were as follows.—

First crop: 50 acres under the fine popular variety of rice, GEB. 24, known locally as *Doppi samba* and 50 acres under another local *samba* were raised. The yield was 2 200 cwt. of paddy.

Second crop: He raised 50 acres under a short duration paddy and 50 acres under white sorghum and from this he got 1,400 cwt. of grains.

Third crop: He could grow a crop only on 36 acres as detailed above and he got 576 cwt. of paddy.

In all he got 4,176 cwt. of grains from 100 acres, besides Rs. 4,000 worth of straw to feed his cattle. From one crop he got in the previous year 2,240 cwt. of paddy only.

Apart from producing more food the monetary gain is also appreciable. During the previous year he spent Rs 4 000 and realised Rs. 20,160 worth of grains. In this year, he spent Rs. 8,260 and obtained Rs. 37,584 worth of grains. The net returns for the two years are Rs. 16 160 and Rs. 29,324 respectively. Besides these, he was able to provide food to a large number of labourers by growing more than one crop and they were all paid in kind for planting and harvest. He is rightly proud of these achievements.

College and Estate News

Students' Corner The students' club activities were nil as the students were busy preparing for the December Terminal Examinations which were held on 9th, 10th and 11th December 1943.

Games Hockey Two matches were played with the Ev-cuees, one of which ended in a draw and in the other the college team won. The first match of the Parnel Cup tournament was played between the I and II year class and the latter came out successful. In the finals of the Coimbatore Athletic Association tournament we were defeated by the Sporting Union.

Cricket Three matches were played of which two were with the Officers XI and the other with the Merchants XI. The following were the scores.

1st Match Students' XI 107 (A. S. Alwa 46 not out); Officers' XI 110 for 6 (N. M. Naidu 26 V. Pai 3 for 23).

2nd Match Students' XI 100 for 5 wickets (A. S. Krishnan 50); Officers' XI 98 (Dr. Venkataraman 34; K. Narasimhan 5 for 33).

3rd Match Students' XI 109 (A. C. Krishnan 36); Merchants' XI 63 (Nagarajan 30, K. Narasimhan 4 for 20).

Visitors Lient. Gen. Hutton, Post-War Reconstruction Officer and P. H. Rama Reddi Esqr., Director of Agriculture visited the Agricultural College and Research Institute, during the month.

Chinese Agricultural Mission Dr. Pan, Dr. Ma and Mr. Chiu of the Chinese Agricultural Mission visited the Agricultural College and Research Institute from 10th to 13th December '43. They visited the several research sections and stations. They were entertained at tea by the Principal and the heads of sections at the Agricultural College, and by Dr. N. Parthasarathy at the Imperial Sugarcane Station, Coimbatore.

Departmental Notifications

Gazetted Service—Appointment, Postings and Transfers

Sri H. Shiva Rao, Assistant Agricultural Chemist, is appointed to act as Government Agricultural Chemist, Coimbatore with effect from 19--8--43.

Sri S. Venkatarama Ayyar, Farm Manager, Agricultural Research Station, Palur to District Agricultural Officer, Guntur.

Sri V. K. Subrahmanya Mudaliar, District Agricultural Officer on leave to be District Agricultural Officer, Kurnool.

Sri K. Jagannatha Rao, officiating District Agricultural Officer, Kurnool, to be District Agricultural Officer, Cuddapah.

Sri Rao Saheb B. S. Nirody, on return from leave, will resume the post of Special Officer for Vegetable Cultivation, Coonoor.

Leave

Sri U. Vittal Rao, District Agricultural Officer, Cocanada l. a. p for 4 months and on half average pay for 24 months from the date of relief, preparatory to retirement.

Sri P. Subramanyam, D. A. O. Cuddapah, l. a. p. for 1 month from the date of relief.

Subordinate Service—Postings and Transfers

Name of officers	From	To
Sri C. Venkatachalam	A. D. (on leave)	F. M. A. R. S. Maruteru
„ M. Achanna Sastry	F. M. A. R. S. Maruteru	A. D. West Godavari Dt.
„ M. Subramania Chetti	F. M. A. R. S. Hagari	A. D. Hosur
Janab Mubammad Obeidullah Sahib	F. M. Koilpatti	F. M. A. R. S. Hagari
Sri S. Ramachandra Ayyar	A. D. Ponneri	A. D. in charge of the Colonisation Scheme at (Uluvur) Paruthikottai, Tanjore Dt.
„ S. Mayandi Pillai	Asst. in Cotton, A. R. S. Nandyal	Asst. in Cotton, Coimbatore
„ P. N. Krishnaswami Rao	Asst. in Cotton, Coimbatore	Asst. in Cotton, A. R. S. Nandyal
„ V. Achutham	A. D. Tiruvur	Food Inspector, Tade- pallegudem (under Grain Purchase Officer)
„ K. Bhaskaram	F. M. A. R. S. Samalkota	do. do.
„ P. Somayajulu	A. D. Ramachandrapur	do. do.
„ S. Sithapathi Rao	Food Inspector, Cocanada	A. D. E. Godavari Dt.
„ P. Sudarsanam	A. D. Gurzila	A. D. to work under the Asst Agricultural Chem- ist (compost scheme) at Bezwada
„ A. K. Ramasubba Ayyar	A. D. Palladam	do. do.
„ U. S. Ayyaswami Ayyar	A. D. Tiruvarur	A. D. in charge of the Colonisation scheme-- Uluvur—Paruthikottai, Tanjore
„ M. J. David	A. D. Mannargudi	do. Kangayampatti, Tanjore
Janab K. A. Shaikat Ali Sahib	A. D. Trichinopoly	Marketing Asst. to work under the Grain Purchase Officer, Tanjore
Sri C. Ramakanta Reddi	A. R. S. Samalkota	Marketing Asst. to work under the Grain Purchase Officer, Bezwada

Janab Md. Zainulabdeen Sahib	Asst. in Paddy, Rice Sub-Station, Buchireddipalam	A. R. S. Samalkota
Sri C. Ekambaram	F. M. S. R. S. Gudiyatham	A. D. North Arcot Dt.
„ K. R. Sundaresan	A. D. North Arcot Dt.	F. M. S. R. S. Gudiyatham
„ V. V. Jagannadha Rao	A. D. Patapatnam	A. D. Vizagapatam
„ G. Venkatakrishnan	A. D. Periakulam	A. D. Salem
„ M. Narayana Ayyar	A. D. Hosur	A. D. Periakulam
„ V. M. Ramuhuni Kidavu	A. D. (on leave)	A. D. Hosur
„ M. P. Gourisankara Ayyar	A. D. Devakottah	A. D. Trichinopoly

The following upper subordinates are appointed as Agricultural Marketing Assistants under the Provincial Marketing Officer for grading and marketing of rice and are posted to the stations noted against them.

Name of officers	Stations to which posted
Sri V. Mahimai Doss, Marketing Asst. Grain Purchase Office, Tanjore	Mannargudi
„ George Maduram, Probationary, A. D. Tinnevely Dt.	Tiruvarur
„ M. Kasiviswanathan, A. D. Kadiri	Kuttalam
„ K. V. Natesa Ayyar, A. D. Gudiyattam	Chidambaram
Janab D. A. Syed Mohammad Sahib, A. D. (under training) Hosur	Trichinopoly
Sri K. Moorthy Raju, A. D. (under Training) Kandakur	Bezwada
„ K. Narayana Rao, A. D. Hadagalli	Gudivada
„ N. Srinivasulu, A. D. (under Training) Tadepalligudem	Bhimavaram
„ K. Raghunatha Reddi, Marketing Asst. Grain Purchase Office, Bezwada	Nellore
„ S. T. Srinivasan, A. D. (under Training) Ramnad Dt.	Madras

Leave

Name of officers	Period of leave
Sri U. S. Ayyaswami Ayyar, A. D. Tiruvarur	L. a. p. on m. c. for 2 months from 4-12-43
„ K. M. Narayana Rao, F. M. A. R. S. Nanjanad	L. a. p. for 40 days from 22-11-43
„ P. N. Krishnaswami Rao, Asst. in Cotton, Coimbatore	L. a. p. for 6 weeks from 29-11-43
„ T. R. Naganatha Iyer, Sub Asst. College orchards--Coimbatore	L. a. p. for 4 months from 8-12-43.
„ S. Bhima Raju, A. D. (on leave)	Extension of l. a. p. on m. c. for 3 months from 17-11-43
„ S. Venkataraman, A. D. Nannilam	L. a. p. on m. c. for 4 months from 29-9-43
„ K. Satyanarayanamurthi, Asst. in Cotton, A. R. S. Hagari	L. a. p. for 30 days from 22-11-43
„ K. Cherian Jacob, Asst. in Botany, Coimbatore	Extension of l. a. p. on m. c. for 2 months from 24-11-43
„ P. S. Venkuswami Ayyar, A. D. Chingleput	L. a. p. for 2 months from 2-1-44

Foreign Service

The services of Dr. R. Kochukrishna Pillai, Assistant in Chemistry, Coimbatore, is loaned to the Council of Scientific and Industrial Research for employment as Technical Assistant, under the Director of Scientific and Industrial Research, Delhi.

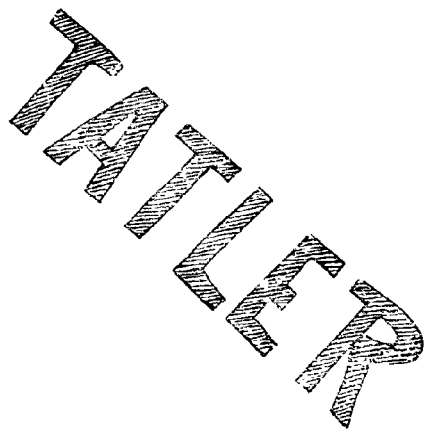
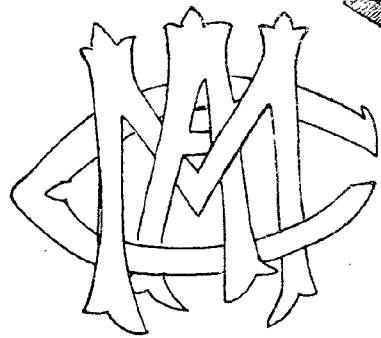

CONTENTS

	Page.
1. The Tatler's Diary 1942-43 <i>By Our Diarist</i>	1
2. Five Annas <i>By R. S. Kollegal</i>	3
3. Cambodia visits Karunganni <i>By L. Neelakantan</i>	6
4. My Hostel Experiences <i>By K. B. Chengappa</i>	10
5. Crowing <i>By Nandi</i>	12
6. Indian Women <i>By C. Srinivasan</i>	15
7. Educated-Weaned <i>By M. V. Gopalakrishna Sarma</i>	17
8. The Final Blow <i>By Narasimhulu</i>	19
9. Phraseology of Agricol <i>By "Gani"</i>	23
10. Is it a Fact?	24
11. Grow More Food Campaign	26
12. "Grow More Food" <i>K. Sanjiva Shetty</i>	26
13. Four Fingers and a Half <i>By L. N.</i>	28

Editorial Staff

<i>Editor</i>	K. V. S. Suryanarayanamurthi
<i>Sub-Editor</i>	K. R. Narayanaswami
<i>Representative—III year class</i>	M. V. Gopalakrishna Sarma
» <i>II year class</i>	P. A. Srinivasan
» <i>I year class</i>	P. T. Bhaskara Panicker

Sectional Correspondents

<i>Diarist</i>	Ch. Krishna Murthy
<i>Artists</i>	V. Rama Rao, K. Rajagopalan and K. P. Kuppaswami
<i>Publicity Manager</i>	G. Prabhakar Reddi
<i>Foreign Correspondents</i>	R. E. Thomas and R. Subramaniam
<i>Local Correspondents</i>	R. Venkatraman and O. V. Ommerkutty
<i>Lighter Vein</i>	E. R. C. Vincent and Narasimhulu
<i>Photography</i>	T. Venkataswamy and K. Sadaçopan
<i>Mess Correspondents</i>	D. Ranga Rao and A. S. Krishnan
<i>Our Cinema Reviewer</i>	N. R. Adyantayya

The Tatler's Diary 1942-43

- June 15. The College re-opens.
- » 16. As usual some students begin serious studies.
- » 17. Mr. Kamath arrives with a large consignment of Mangalore *beedies* for distribution among the *beedi* patronisers.
- » 21. Hostellers busy due to the impending elections.
- » 23. Mr. Chengappa arrives with a hockey stick for his interview.
- July 2. Mr. Kamath goes to the first year blocks, impersonating the Warden but returns after receiving a 'grade'.
- » 10. Mr. I. L. Narasimharao lodges a protest with the Warden saying that a sufficient number of 'extras' are not being supplied to him.
- » 24. Mr. Francis Gurubatham attends the picture-house for the first time in his life.
- August 11. Mr. Ramanatham takes his monthly bath.
- » 12. Mr. Srinivasan resigns his Club secretaryship.
- » 14. Mr. Venkatraman is elected in his place.
- » 15. Mr. Venkatraman goes to the town for buying a suit and shoes.
- » 26. Maiden attempt by Messers Ramakrishna Sastry and Vincent at shaving.
- Sep. 1. Ramakrishna Sastry elected as the mess-representative for the new mess.
- » 2. Mr. Narasimhan attempts at spin-tennis.
- » 17. Mr. Nargunam buys a second-hand pith hat.
- » » Most of the students leave for their homes as the examinations are over.
- » 19. Mr. Ammiraju replaces his *Kasi chembu* with a tin-can.
- October 3. The students return after the holidays.
- » 5. The examination marks begin to be announced to the inconvenience of some.
- » 10. Mr. Cripps arrives after having an extra spell of holidays.

- Oct. 12. Messers Shanmugam and Govindarajulu enter the picture hall to see 'Doctor' but are surprised to see Sakuntala on the screen. They swallow the pill and return to the hostel disappointed.
- » 22. The third year students leave on a week-end tour to Palghat.
 - » 23. Some casualties of the above trip take to bed.
 - » 24. The Grow More Food campaign is inaugurated in the hostel by the Warden.
 - » 30. The third year students leave for Palayakottai with five students less.

By Our Diarist

STOP PRESS

November 7th—Mr. V. L. N. Sastri beats the previous *idli* record by eating 26 *idlies* at a stretch. Our congratulations.

The Agricultural Graduate

A sound training in the basic sciences not only makes an agricultural graduate more proficient in his chosen field of applied science, but it also makes him a more versatile and therefore a more useful citizen in war as well as in peace.

L. E. Kirk, J. Amer. Soc. Agron. Dec. 1941.

Five Annas

By R. S. KOLLEGAL

FOR five years myself and my wife were thinking of electrifying our house. As usual we never came to any definite conclusions. One day, I finished my meal and was about to start for the office, when my wife came to me with a long list of things like chimneys, kerosene, etc., to be bought that evening. She began—

“Considering all these things, it is better we electrify our house”. I was surprised to see my wife come to such a definite conclusion in so short a time as five years.

“Yes! that’s what I was also saying from the beginning. In these days almost all the houses are electrified and further if we electrify our house it would save you a lot of trouble. You would not have to clean the chimneys and lights nor pour oil on the ground thinking all the while that you are pouring it in the light.”

“Oosh! you speak as though you are going to electrify the house to save me some trouble.”

“Further, you finish off at least six chimneys in a month. That will be a saving hereafter.” I continued.

“As if I wantonly do it. Sometimes they slip off and break. If you buy good, durable ones there would be no such difficulty. You always go in for third-rate stuff and you want them to last till your grand-son begets a son.”

“At least so far as I am concerned, my brain refuses to work when I begin to write articles under oil lamps.”

“Why blame the oil lamps for that when the mistake lies with your brains?”

All the while I thought she was trying to take the offensive, as usual, but when I learnt that she had actually taken it, I thought it advisable to change the topic in the interests of both. So I began,

“So, I will place an order with the local contractor to-day. In the evening be ready to go to the theatre.”

“But we must know what the initial costs are likely to be.”

“Why do you want that? You ask for every detail as though you are paying from your privy purse.”

“Not that. What I meant was the monthly bill. Whether it would be economical or not.”

“It is sure to be economical, so long as you do not break chimneys and waste kerosene oil.”

At last, our house was electrified. Whenever she finds time she will be found standing in front of the meter. Fortunately the meter-board was inside the house and not on the veranda as in so many houses. In a week the meter showed '4'. I was just dressing myself up for the office when my wife came running to me and said.

"What is this? In a week the charge has come to Rs. 4. Hereafter we must be very economical. We must sleep before 9 o'clock and on no account should the light burn after that."

I nodded my head in approval.

Writing articles was my pastime. One night I was seriously thinking of writing a new and funny article—"Oh! these hen-pecks". I was thinking as to how the article should be—an essay or a short story or a narrative or in the form of a conversation between two henpecks—when came the thunder-bolt.

"Why are you sleeping with lights on?"

"Choo! don't disturb me. I am seriously searching for an apt word".

"Serious thinking does not require bright lights .. ." and she put out the lights.

I went and switched on the lights. But she again switched them off. This process of switching on and off happened for 5 or 6 times. I was not able to make out whether it was the beginning of a new life. I was reminded of the early married days.....there my writing an article came to an abrupt end.

A month later the meter showed a reading of 12, only 12, my wife was shocked when she saw this and came to the quick conclusion, arrived at, all by herself, that the bill is Rs. 12. She thought I was duped and advised me to enquire in the municipal office. I was enjoying all this, though I felt for her innocence.

The next day the monthly bill was received, and it was only for Rs. 3 for 12 units. I showed it to her thinking that she would compliment me for my performance.

"So, only three rupees. How much we have saved this month! If we are careful we can save more" said I.

"Three rupees! What were the lighting expenses last month? Five bottles of kerosine at 2½ as. per bottle, six chimneys, three for the hurricane at the rate of 5 as. each, one at 2½ as. and another two for the bed-room light at 1½ as. each, three wicks at 3 ps. each. What does the total come to?"

Poor soul!, she did not know that I was not a Ramanujam, but only a graduate in natural science, who passed S. S. L. C. by the generosity of the Moderation Board getting a bare minimum of 25%

in Elementary Mathematics. So, I said at random “2—11—0” and that we are paying only 5 as. extra for the extra brightness we got for the house.

“What!, you say only 5 as. ?—in these days of economic depression 5 as. means 2 seers of good salt enough for a month. In a year the excess would come to nearly Rs. 4. You are very liberal in all these things but when it comes to the question of buying a good saree for me you say funds do not permit”.

The reader may think that I belong to that group of fortunate people whom the world mercilessly and arrogantly call “hen-pecked”. Only when you are hen-pecked—though others would think that you are in trouble with your wife—you would feel that you are in heavens.

That night I heard my wife murmuring in her sleep—“5 as. means 5 as.”

A Doubt

Although he was very keen on his study, the new student to the dairy was finding things very strange there.

After having an incubator explained to him by the Manager, he was asked if he understood how it worked. With a puzzled look in his eyes, he replied :

“Yes; but I can't see where the hen sits.”

The Eleventh Commandment

“Thou shall inherit the holy earth as a faithful steward conserving its resources and productivity from generation to generation. Thou shalt safeguard thy fields from soil erosion, the living waters from drying up, thy forest from desolation and protect thy hills from over-grazing by thy herds so that thy descendants may have abundance for ever. If any shall fail in this stewardship of the land, thy fruitful fields shall become sterile, stony ground and wasting gullies, and thy descendants shall decrease and live in poverty or be destroyed from off the face of the earth.” *W. C. Lowdermilk, Poona Agric. Coll. Mag. Feb. '43.*

Cambodia visits Karunganni

(An imaginary conversation among cottons)

By L. NEELAKANTAN

Prologue (While on a tour of sight-seeing in the black cotton soil of the Tirunelveli district, two cotton strains, Co. 2 and Co. 3 meet their confreres—*Karunganni*, *Uppam* and *Pulichai* and engage them in a pleasant conversation.)

Karungannis (all) Hallo! big brother, whither and on what errand?

Co. 2 Just on a joy visit to this side of the country to renew old acquaintances. Let me introduce to you my cousin hailing from distant Uganda and married and settled in our country.

First Karunganni I believe he is Co. 3. We have heard much about him.

Second Karunganni (slyly) Ever since he came to these parts, I guess, our old brother has been losing popularity. I can tell it from his wan face. What brother, don't the good *ryots* need you any more?

Co. 2 Pray, gently, there is no need to be presumptuous. I am alright but what about yourself. Don't you know that since K. 1 rose amongst you, you are being eclipsed yourself. Funny that you should miss the beam in your eye.

S. K. We know that. He is our own dear cousin. Only he had the fortune of basking under the genial sunshine of Government patronage at the Koilpatti Agricultural Farm. So a special importance attaches to his name.

F. K. But have we not ousted out these *Uppam* chaps? Has our big brother any such achievement to his credit? He dare not measure his prowess with Co. 3.

Co. 2 (laughing) Oh! What folly to fawn on K. 1 on the slender plea of kinship. In a few years he will occupy every inch of land that you are now on. This is certain.

Co. 3 Suppose my cousin and myself go all out on a campaign of occupation in these places. I wonder if you can stand up to us.

(All the *Karungannis* burst into a peal of laughter and Co. 3 feels confused and awkward).

Co. 2 (smiling) Pardon, brothers he is yet new to the conditions obtaining here (turning to Co. 3) Funny, cousin that you talk in this manner. Don't you know we can't get on without plenty of water baled out from wells. In this dry black clayey soil where our friends here revel and make merry with what little of water that a miserly monsoon provides, there is none in our race who can stand a competition with them.

Co. 3 (apologetically) Sorry, gentlemen, but I don't mean serious. Er, cousin where can we see these *Uppam* people?

F. K. There, on a piece of elevated light soil you can see the *Uppams*. We have relegated them to such odd places.

Co. 2 Thank you, friends, good-bye.

Co. 3 Ah! these are the *Uppams*, I suppose. What grace and what charm. Gorgeous as the parrots and quite hale and healthy; how I pity their fate.

Co. 2 It is all appearance, sir, and nothing more. They do not have such quality stuff as the *Karungannis*, neither are they so industrious. They are weak and vacillating.

Uppams (all) Welcome brothers, how do the *Karungannis* fare. We saw you talking to them. They are a strong race and hate us.

Co. 2 Happy to meet you brothers, but why worry about the *Karungannis*. They dare not wipe you out from the district.

First *Uppam* No, they will do it; they can and are still stirring.

Co. 2 Can't you get on together in a spirit of co-operation.

F. U. No use brother. On our part we have been accommodating to the best possible extent knowing our limitations. Fortunately good mother earth has given us pieces of land which are not suitable to the *Karungannis*. While we are thus protected by nature from invasion, we are exposed to another temptation for which I hold our common phylogeny is responsible. Members of our race take a fancy for members of the *Karunganni* race and illegitimate unions take place resulting in the birth of a race of cross bred. While these images of sin may not be a serious factor among the *Karungannis*, they are a problem to us. Limited as our race is in population, these happenings tend to check further our efforts in maintaining our integrity and character unsullied from generation to generation. Alas! most of the good farmers consider us as inferior to the *Karunganni*.

Co. 2 Hang the *Karungannis*! haughty chaps. You too had your halcyon days and are still having a fine time in other parts of the world. You will see the downfall of these *Karungannis* ere long.

F. U. May be! they too are not quite happy. Quite recently another race is worrying them. This is the *Pulichai* race; it came somewhere from the north and bids fair to settle down comfortably in these places. Yonder, there on the fringe of our occupation, and quarrelling with some *Karungannis* in the out post of their territory, you see one such fellow; tall, scraggy with sharp features and a look of supreme contempt in his face; that is the *Pulichai* fellow; a cunning rogue. He is a nightmare to all of us in these parts.

(The *Pulichai*, not very far off overhears and addresses Co. 2.)

Pulichai Brother Co. 2, what timid creatures are these *Upsam* girls. I pity them. But these *Karunganni* fellows, well, I hear stories of a new champion among them, K. 1 they say. How is he like, brother. That vain prig is perhaps not aware of my valour. He may be the best of *Karungannis* but he can never trespass the border of his species. Let him not cross me. Very shortly I will be marching a whole army of my people to take possession of these lands. There is not space for us in our home, and we find this tract very congenial to colonise.

Co. 2 (smiling) Well spoken, burly rogue. You may be strong, sinewy, coarse, tardy and capable of much endurance. But these alone are not enough to keep your race away from the dangers of extinction. Where are the mighty dinosaurs and the giant mammals that ruled the land, sea and water in the ancient past. Brother, *Pulichai*, I am not discouraging you, but you make light of the qualities of K. 1 and there you commit a blunder. In days of yore the demon Kamsa spoke tauntingly of the Lord in His boy incarnation just as you are doing now and you know how the story ended. I am not quite sanguine about your future. God be with you, good-bye!

(A field populated with K. 1.)

K. 1 (all together) Welcome brothers Co. 2 and Co 3. How do you do ?

Co. 2 Yes he has not been here before and he is very eager to have your acquaintance; but pray how did you know my cousin Co. 3.

First K. 1 As if it were a wonder! We have heard a good deal about him and the description is exact.

Co. 3 Thank you, I too had just now occasion to know all about you through my cousin Co. 2. All the *Kaungannis* speak highly about your qualities of head and heart.

Co. 2 Why not? the good farmers and the benevolent Government themselves testify to his greatness. What better references need he have.

F. K. 1 Please, brothers save us from embarrassment by these bare-faced compliments. We are merely stirring hard to be of the best possible use to our benefactors. We pray God that He may help us in our efforts. Honestly we have no intention of competing with our cousins.

Co. 2 and Co. 3 God will help you, you will succeed, good-bye.

Co. 3 What modesty and what noble views. Though short and stubby these K. 1 are really people with substance. But why are they sad, some of them at least; I noted distinctly.

Co. 2 I too noted. Poor chaps. Their constitution is not quite up to the mark. You know the wilt disease that is causing so much havoc in other parts. Well, some of these K. 1 happen to possess low resistance and they succumb to the attacks. But they are being looked after properly; well, hurry up please. It is quite late. There an Agricultural Officer is expatiating on the qualities of K. 1 to a group of cotton growers. Let us hear him and then turn homeward.

Epilogue An Agricultural Demonstrator to a group of ryots somewhere in the Tirunelveli district.

“K. 1 is a pure and improved *Karunganni* strain of cotton born at the Agricultural Research Station, Koilpatti. There is a saving of a few rupees per acre by growing it in the place of *Karunganni* or *Uppam*. It yields 450 lb. of kapas to the acre whereas your local yields 300 to 400 lb. It has a high ginning percentage—33, whereas yours gins to 30's. A smaller area is enough to raise a required quantity of kapas for which a correspondingly greater area of your cotton will be necessary. You can utilise the extra space thus released for growing more food crops. So go in for K. 1 cotton”.

A Specimen Application for Leave

Name of student: X, Y, Z.

Class: V.

Reason for absence, Tiffin not available.

Period of leave; From 8 A. M. on 6-10-42 to 11 A. M. on 6-10-42.

Number of working days: ½ a day

X. Y. Z.

Signature of student.

Date: 7-10-42.

Remarks of the Warden

Produce M. C.

(Sd)..... 8-10-42.

Not recommended.

(Sd.).....12-10-42.

H. W.

Signature.

Date - 12-10-42.

Orders of the Principal.

See the Principal.

(Sd).....13-10-42.

Not granted..

(Sd).....18-10-42.

P.

Initials.

Date: 18-10-42

Communicated to the Warden: 20-10-42.

Communicated to the student: 25-10-42.

Returned to the office: 27-10-42.

(With due apologies).

My Hostel Experiences

By K. B. CHENGAPPA

(Herein we give you the experiences and feelings of one of the new students, from his own pen. We wish to tell the readers that the student concerned is not known to be a light eater. *Ed. Tat*)

OUR mess is the only non-vegetarian mess in the hostel. It is named so because most of the members in this mess are thorough non-vegetarians. But it ought to have been named as a semi-non-vegetarian mess as it is mostly vegetarian. Out of the 14 meals you take per week, you can expect only four times meat. When eggs and fish are considered to be vegetables and taken by many vegetarians, why not sheep be considered as inflorescence for its fleece? Because of this, I think so many who used to shudder at the sight of the N. V. Mess now join it in large numbers.

Early morning you have to get up and rush to the mess, if not, you may be late to the class. You must remove your slippers at the door. But if you happen to wear shoes or boots you have to remove them standing, running the risk of falling down as you may lose the balance while doing so. You find inside small planks raised hardly one inch above the ground and here also you must be careful lest you should lose your stability. The cooks with *Jhoties* (which I am sure were washed before the beginning of this year) as black as tar will enter to serve. You will be supplied with 1 *dosai*, 2 *puries*, 2 *idlies*, or 2 slices of bread which may not be sufficient to reach even the oesophagus. The bread will not be with butter. I would propose in this case to have a dish of butter safely placed beyond our reach but in full view of all the members so that you point the piece of bread in the direction of the butter and satisfactorily eat it. You are supplied with coffee also which many of us suspect to have been prepared with quinine, being as bitter as Margosa.

Then you will go to the Central Farm, from which you will be taken to, most probably wet-lands. There you are expected to work, while it is quite impossible as there is no 'petrol' in the stomach to control the plough or the pair of bullocks. After sometime you will be asked to come out, but you will not be able to pull out your legs out of the mire. Anyhow you manage to come out as you want to return to the hostel. Then the Professor will give you some hints about the work you have done and how you could have done it better (if only you had stamina enough, to put forth.)

After this you will have to run to the hostel so that you can get water for your bath, as there are only two bath-rooms for 40 students.

I think that is why so many are becoming the members of the Anti-bathing Club. As there are eight bath-rooms for the Third Years who are 30 in number, you will be tempted to go there as there is more water. But those generous people will object to this and may even trap you inside the bath-room and declare in unmistakable terms that the bath-rooms and the flushouts are luxuries for the use of only the privileged Third Years. (Imagine the plight of the Third Years if 40 students raid the bath-rooms and latrines, constructed for the use of 30 students. *Ed. Tat*).

When you finish your bath, it will be about 11 A. M. and all, hungry like wolves, but, must wait for the arrival of the prey, for your attack will begin only at 11-30 when the mess-bell rings. For your mid-day meal you first get rice and ghee. You will be served next some curry 49% brinjal and 49% plantains which I think contains the most nutritive matter and vitamins as this is an Agricultural College. Some *sambar* comes next, which will contain some drumsticks (which is supposed to improve the brain) suspended in it, or some tomatoes, once in a month, as these are the cheapest vegetables available in the orchards. After finishing your attack on this, you get *rasam*. This solution contains in it everything except pepper with which the *rasam* is supposed to be prepared. This, when poured out will be in floods in every direction and will threaten to go out of the leaf and so you must finish it as quickly as possible. After this solution, you are supplied with curd which is the only nutritive food in the mess. But I don't know why this has been also recently stopped. It may be due to the rationing of milk supplies, due to war.

At 2 o'clock you have to go to the class again. At the end of the first period you cannot remain there as you will be hungry again. You control this and come to the mess at 5 P. M. You will get some 'sweets', the contents of which no research scholar can analyse except the cooks who prepared it and a 'savoury' or a plantain and some 'mixture'.

After the night meals you come to your room and when the Warden finishes his rounds with his 'famous' petromax, you feel like eating again, but there is nothing except the books and the clothes in your room. So you will have to go to bed early so as to forget the hunger. Often water too will not be available in the jug as the venerable old gentleman who supplies drinking water might have been stranded on the way struggling with his bullock which is as old as himself. One good effect of our mess is that the agricultural graduates who become cultivators of their own lands may be prepared to withstand famines. So better join our mess as early as possible. Do not waste time. A single trial of our mess will lead you to become a member of our mess for ever.

Crowing

By NANDI

I happened to go through some letters written to students by their well-wishers in which I noted the following sentence. "Be friendly with your Professors and college authorities". Though the words were not the same in all the letters, yet all contained the same meaning and were more or less the allotropic modifications of the above sentence. What does this mean? Will it be that fatal word—that word 'crow-catching'? It is very difficult to find an answer to this question.

Here the scientists come to our rescue. Whenever the scientists are baffled by a certain phenomenon and whenever they find it very difficult to explain the why and how of it, they simply say that it is a law of nature. Like this 'crow-catching' may be said to be a law of nature. But there is no harm in defining it as follows:—

'Crow-catching' can be defined as that art or science, or both, by which the inferior sections of the humanity of this world try to win the affection and sympathy of the superior sections under different conditions of rank and position.

'Crow-catching' is in-born in everyone. Thomas Hughes said in *Tom Brown's School-days* that fighting of one kind or another is a law of nature. But I dare say that 'crow-catching' is a law of nature. When you are born in this world among the erring humanity you cannot avoid 'crow catching'. You have to do it in one form or other. But in some it is found only in a dormant form while in others it is well developed. Some are born 'crow-catchers', some achieve it and some have 'crow-catching' thrust upon them.

As I have said before it is very difficult to say whether it is an art or science. But it could not be a science because in our college where almost all sciences are taught, some necessary and some unnecessary, the authorities would have included this as a subject, if it is a science. Will it then be an art? In that case it would have been added as a subject in the III group in the Inter. Just as we have got Indian history, modern history and logic we will then have Indian history, modern history and 'crow-catching' or physics, chemistry and 'crow-catching' i. e., the III group will be a permutation and combination of physics, natural science, chemistry, mathematics, 'crow-catching', etc.

In these times when various experiments are being done to modify the system of education I would safely recommend the inclusion

'crow-catching' as an optional subject either in colleges or schools. It won't be out of place if a Diploma course is given in crow-catching so that the students will get the diploma D. C. C. (Diploma in 'Crow-Catching'.) Will they do it? I call upon expert 'crow-catchers' to give their calm, cool, and undivided attention to this problem. In these days of economic depression and unemployment it is a source of employment for expert 'crow-catchers', and they will be doing a great service to the 'crow-catching' humanity as well.

'Crow-catching' is a vast subject and it is beyond the scope of this article to explain it clearly. But it won't be out of place if I cited some of my experiences in the art of 'crowing'. While at school a teacher who was terribly wild and was rushing to thrash a boy was brought to a standstill, dumb struck when the boy murmured a few words. What were those magic words? The boy murmured, 'Sir, my father wanted me to ask you whether you will be kind enough to give me tuition in physics'. Certain conversations followed and some days later, it was a wonder to me when the teacher smiled even when the boy was unable to explain the Archimedes' Principle. For the teacher has become his tutor adding Rs. 25 monthly to his scanty income. What will you call this? Teacher 'crowing' boy or boy 'crowing' the teacher? Or both?

But in colleges you will rarely succeed in 'crowing' professors by promising to be a 'tuition-boy' under him. Here you will have to adopt other methods.

When one wants to 'crow' a person, he must be very careful and must know when and how to 'crow-catch'. If you know this you have studied half the art. You must know the mood of the person whom you are going to 'crow catch', whether he has quarrelled with his wife, or whether he had a nice time with his wife, and so on and so forth.

Salutation is of first and foremost importance. How to begin the conversation? Here also you must use your intelligence. In some cases you can directly approach by saying "awfully bad weather, sir".

You may even talk of politics. But the important thing is you must never oppose his views. If he says that Napoleon was the King of England or Lord Ravana defeated Demon Krishna at the battle of Waterloo you must simply give an appreciative nod conveying, yes, even if you know well that he is in the wrong. This is the secret of success.

If you happen to see the son of a gentleman whom you wish to 'crow', you can consider yourself to be lucky and it is a red letter day for you. Easily approach him, nicely and scientifically, and load him with biscuits and peppermints and memorise him with your name

so that he can say to his father that you supplied him with those edibles. Be careful to wrap the edible in a secure way in a piece of paper. Otherwise the boy might eat it on his way and your whole attempt will be foiled.

After all, will inviting to dinner or garden party be a means to 'crow catch?' Yes, it is. But it is expensive, for you will have to pay for his dinner and the public may know why you asked the gentleman to dine with you.

Try to become, conspicuous in the eyes of the people whom you wish to 'crow-catch'. In an educational institution, when the lecturer asks whether you have any doubts, stand up at once and ask some doubts, whether you have got any doubts or not. Request him to explain the last year's portion once more or ask him any question, connected with the subject or not. What do you care? Your aim is to 'crow-catch' and the lecturer's aim is to teach and both will be satisfied. Ask him why he is having a turban, instead of a hat or *vice versa*. Ask him whether the flavour of Virginia tobacco will be the same in America, England, Germany, France, Australia and India. But of course you must be prepared for the eventuality of being snubbed. But don't be discouraged. Failure is the stepping stone to success. Go on. Let God be with you. Long live 'crow-catching'.

New Term Resolutions and Revolutions

Chengappa To come to the class as early as possible.

Thomas and party Not to hold separate classes during the agricultural practical class while the lecturer is telling something interesting.

Nambiar To take a bath at least twice in a month so as to smash all previous records and set up an example to his followers, the members of the A. B. C.

Story-teller Not to catch any more crabs by introducing frog's legs tied to a stick into crab-holes, as the animals will suffer much.

Hostel-stewardā Not to put water in the jugs on the verandahs as water is scarce and the monsoon is delayed.

Tobacco expert Not to interfere in the middle of a lecture too frequently.

Smoking volcano Not to absent from the classes for the sake of taking oil-baths and shaving.

Dhaincha expert To help the Grow More Food campaign, by lending his services fully.

Azinuddin To block all the windows and doors of his room and make it light-tight and air-tight, as a preliminary for future stay in A. R. P. trenches.

Hostel Radio driver Not to meddle with the radio too frequently so that it may work properly and the members may benefit by it.

Vincent Not to stay for more than 5 minutes in others' rooms.

Indian Women

By C. SRINIVASAN

SELF-forgetfulness and self-sacrifice form the focal points for which an Indian woman lives in an Indian home. As daughter, as sister, as wife and as mother, she lives to make the home an abode of peace, purity and patience. Her influence in the home is as great as that envisaged by her Western compeer under a civilization quite different in aim and aspect. The secret of this influence lies in her life of self-devotion to all that go to preserve the peace and prosperity of the home. She offers the most impressive exemplification of the fact that she sets herself wholly for the service of the family.

The nature of woman is evidently dependant in accordance with the concept of *Dharma* in every stage of her life, upon the father during girlhood, upon the husband in the middle age and upon the son in the advanced life. Though she is physically weak, she stands any amount of suffering and service. In the very organization of our society and home, and in its regulation, the woman plays no little part. It is not by strength and vigour that a woman gets distinguished, but by lovable service and suffering.

It is the law and custom of our land that lay hold on these endowments of nature and give it the environment needed for its perfect development, *i. e.* the life of honourable dependance on man. This does not mean a life of slavish subjection but it is freely assumed that they take the proper place in the home. The activities, the interests and the opportunities for earning distinction are entirely confined to the home. It is generally believed that if women engage in social and public affairs or for earning wealth and fame which the sphere of public life offers, this state of dependance which is so valuable to us and also suited to their essential disposition, will cease to be a reality. It is fiction to assert that our women do not receive any education at all but it is a fact that they do not receive an education which makes them into, like many of our men, endless quill drivers, rapid social reformers, or briefless lawyers. They are necessarily kept out of this because they are engaged in a more useful work of house-keeping. Even as matters stand, we have in our homes, women commanding genuine respect of all she knows. Indian women are quite satisfied with what knowledge they acquire at home, for it is considered sufficient for the due performance of their functions within the household. We all know her influence in all transactions of our domestic life. It is paradoxical enough, that even in a life of dependance she raises to unquestionable dominance in the conduct of the home and domestic expenditure.

Our educated men may struggle for years without success to dominate the province of house-keeping, having in view the family tradition so jealously guarded by the women of the house-hold. The religious life of the household is dictated by our women with their conservative instincts. The modern man's agnosticism and radicalism fade away before the determined Indian woman's pious devotion to her ancestral rites, customs and beliefs. "In the West, the woman is wife. To the Indian the whole force of womanhood is concentrated in motherhood. In the Western home, the wife rules. In an Indian home, the mother rules."

The existing conditions of the society in relation to the place occupied by women should never be altered. Any change to reform may destroy the very basis of our society. The excellence of this lies in the strength of passivity and can preserve itself against any insidious attempt to destroy the source of vitality of our ancient race.

Definitions

Gunter's chain It is a kind of chain used by hunters for tying the prey to a peg for hunting tigers.

Blastostyle It is the style of a flower with a polycarpellary pistil.

Monocyst It is a kind of reproduction common in the protozoan forms in which a single cyst is formed. Inside the cyst numerous forms are produced by division.

Pugmill It is a kind of machine involved in machine moulding. In this bricks are moulded by dry clay moulds. It is also applied at times to students who are able to mug well.

Educated-Weaned

By M. V. GOPALAKRISHNA SARMA

THE masses of any country, where progress is aimed at, look up to their educated brethern for leading them to a better and nobler plane in all walks of their life. In most of the countries the response from the latter is encouraging. But in our country it is otherwise. The reason may not be so clear as it ought to be; but yet it is there, vivid and visible, for those who bestow some attention on the conditions prevalent in this country. The pitiable plight in which our educated are placed is heart-rending. They have become the bane of the country in that they can support neither themselves nor others.

The gulf existing between the masses and the educated, as we find to-day, is very wide. We can call the *intelligentia* the "brain of the nation". There is a vital link between the sophisticated and the un-educated even as that between the brain and the body. Derangement of any one of these parts spells disaster for the entire system. Any move to bring about a drift between these two will disturb the equilibrium. If the country is to be rid of all these the educated must recognise their brethern, illeterate, as none else but the same stock from which they themselves have sprung up. They must feel and work as part of the populace. With the artificial barriers as are seen to-day, there is little hope of any real progress being achieved in the direction of ameliorating the distressed state of the people at large.

But unfortunately the educated are far removed from their natural seat of life. They have almost lost the identity with the life of the folk in the village. To them the village, with its supposed unbearable monotony, is least tempting, and the petty quarrels and quibbles are disgusting. They resent the very mention of rural life.

But the causes for this tragedy are not wholly theirs. They are brought up in an artificial atmosphere that supresses what all emanates from within. Having been stuck deep into the mud of false prestige, he who drudges from morn till eve will have no place in their mind. A thick opaque screen is placed between them and their toiling brothers who really feed the entire nation.

Having been trained thus the educated man will be dreaming of a rosy future, concentrating all his energies to win some laurels for himself. The last traces, if he has any, of his sympathies for those on whose sweat of brow he lives, will dwindle away into oblivion, when once he succeeds in his laurel-hunting. He who fails to get access to

what he aims at, feels helpless and slippery. He loses his self-confidence, and the future seems to him very gloomy and discouraging. He will be hovering between the outskirts of town and village, entering neither of the two; the former because he has been spurned in spite of his liking and craving, and the latter since he thinks it degrading to live there amidst rural folk.

We can now see how the educated have been weaned from the masses to the advantage of none. These two sections have been made into two water-tight compartments. Such isolation is harmful to the entire nation. Consequent on this segregation, the national standard in all spheres of life has been subject to steady deterioration. So it is our paramount duty, before it is too late, to dive deep into the whys and wherefores of this tragic state of affairs and soon establish a life-line between the intelligentia and the unsophisticated of the country.

First aid

Having attended a first-aid lecture, the young wife was quite pleased when the hubby came home looking and feeling seedy. Proudly producing her thermometer, she proceeded to take his temperature. The result so startled her that she sent a note to the doctor at once. "Please come at once, my husband's temperature is 136". Soon came the reply: "The case is beyond my skill send for the fire-engine."

Employ Agricultural Graduates

A modern war is a total war, so that matters of food production and problems of nutrition, are as much a concern of defensive and offensive warfare as the building of ships and aircraft. Hence technical agriculturists are as necessary to the war effort as engineers. It is not a question of guns or butter, it is really a question of guns and butter. *L. E. Kirk, J. Amer. Soc. Agron. Dec. 1941.*

The Final Blow

(A short story)

By NARASIMHULU

WE were then doing osteology in human physiology and on entering the lecture theatre, I beheld a new human skeleton, hanging from a stand. As it took a few minutes for the lecturer to come in and engage us, I sat gazing at the remnants of the human being, who was doing immense service to the student-world after his death. I was trying to imagine its owner's history both before and after death. Just then, 'boredom' entered the class room in the guise of a lecturer. I was taken aback at this expected but undesirable arrival. Outright he began his lecture and I had to follow him, though with a mild curse. Our lecturer did not seem to believe in the wisdom of doing one thing at a time. His amendment to this universal maxim was that 'two' should take the place of one, of course a matter of altering two letters. He would go on dictating and while we went on with the pen, he would his explanations, begin. Unfortunately we have no two heads though some had the privilege in mythology. Of course we all know how far our lecturer and we were successful in this dual attempt. Thus my thoughts about the skeleton vanished from my mind as darkness before the morning sun.

The 'great barons of my mind' did not allow any corner for the skeleton till I went to bed, after effecting a strict black-out, between the four walls of my room. As I lay on my bed, patiently bearing the music of the mosquito and musing on the skeleton, "the gentle thing, beloved from pole to pole" as Coleridge put it, took possession of me.

Suddenly the skeleton appeared before me not only clothed in flesh but also in fine garments, how beautiful and lovely! And narrated the following incident:—

It was a fine evening, calm and beautiful, in the month of May, when Mohan and I met for the first time in our lives, while going for a walk. Though we were accidentally introduced to each other we became friends and our friendship was cemented further, by frequent meetings. This friendship resulted in love for each other.

"I charge you, Kamala," he once said, "with the crime of usurping."

"How and why?" I enquired.

"By nature, as you know, I am an admirer of Nature. But now in comparison, She is next to nothing. Each touching scene that

passes before my eyes, makes me think, that grace, if at all they possess any, has been borrowed from you. Look at those green corn fields which fired to inspiration, by the gracefulness of your curls, are trying to imitate the wavy nature of your locks. The rich golden colour of the west, unable to compete with your rosy complexion, is receding into darkness. In short I transferred my love, admiration and adoration from nature to you!"

"By way of describing the graceful scenery you are uttering deliberate lies! But as per your transference of love etc. don't repeat the process once again!" I remarked with a laugh.

"Don't you prick my heart, my dear, with such harsh words. Though you utter them playfully, I am very much pained at the remark. My words are not lies, why! Not even exaggerations! You see those very flowers attracted by your beauty, are struggling to be detached preferring your locks. You know that Jagdish Chandra Bose once said that, when a lovely lady sees a beautiful flower, not only the lady wants to have it but the flower also equally desires to be in her locks. By-the-bye, when is our marriage to come off?" he asked, sending a smiling glance towards me.

"Why are you in such a hurry, Mohan. Hasty marriage seldom proveth well" I replied, returning the smile.

"May be," he said, "but, our marriage does not fit that description. I would we were married soon!"

"Let that be so!" With these words we started towards our house, hand in hand.

A few days after this incident, Raja Ram, a friend of mine, living in the same street as mine, called on me and told that he had something of importance to be discussed with me. After beating about the bush, enquiring about my health, and the whereabouts and welfare of one and all of our family members and relatives, he burst out—

"Kamala! I hold the olive in my hand. To be plain, I seek your hand in marriage".

This shock was quite unexpected and puzzled and perplexed me. Controlling myself I coolly told him, "Sorry, friend. I am not in need of yours. You may have the kindness not to speak on the topic any more".

"May I know what you mean?" he put in, with a face showing amazement, anger and shame.

"I mean what I say" I retorted.

"Then, is my offer rejected?"

"I can't but do so".

"Is there no possibility of altering your decision?"

“No, not at all!”

“I shall see”. With these words on his lips he made an exit.

Two days later, Mohan told me that he was leaving our place the next morning with his father, for his native place. He assured me that he would be returning within a fortnight and promised that he would be writing to me. But later I did not receive any letter from him. Every morning would find me in great expectation in spite of consecutive disappointments. All my endeavours to get a clue of him were futile.

* * * * *
* * * * *

I was going through the strategic retreat of the German troops from X to Y, in the morning papers, when the post brought me a letter. Glancing at the writing I danced with joy for it was Mohan's. I rushed upstairs, to my room, to escape the notice of my mischievous brother. I carefully opened it and hurried through. Ho! what a surprise! letter in hand I fell to the ground.

What happened next, I do not know. When I regained consciousness, I found my brother and father sitting on either side of my bed and comforting me. After a time, my father went downstairs. I searched for the letter and read it again. It ran thus:—

Dear Kamala,

You will be greatly astonished to know that I have been married to my uncle's daughter. I was not able to go against my father's will. He denounced all inter-caste marriages and moreover my uncle's daughter is an orphan. She has none to look after herself and her property. Please excuse me. Shakespeare is right when he says marriage comes by destiny. It is vain to quarrel with our destiny. 'The decrees of destiny are immutable, its decisions have no appeal, what fates impose that men must needs abide'. Time is a perennial river and human beings are the suspended particles in its current. Two particles come together at times, float together for a time and finally they depart, as they should. I write this letter not in ink but in the blood of my heart, Excuse me. Adieu.

This time, I got wild not only with the author of the letter but also with the author who had been quoted. Did not that silly Shakespeare say that men are masters of their fates and that the fault is not in our stars but in ourselves. I doubted whether he has a heart at all. I sent a telegram, with the help of my brother, congratulating the 'usurper' of my heart.

Slowly I caught the wind of Raja Ram's wicked plans and evil intentions. The very place, which I liked so much was a disgust to me and the very scenes which used to attract me hitherto were

mocking at me. They were even ashamed to face me. My disgust for this wicked world grew day by day and many a time I thought of putting an end to my wordly life. All these told badly on my health.

One day while at the hospital, I met the lord of my heart who did not even care to glance at me. When I saw him and Raja Ram, the cruellest of human beings, conversing intimately and sending a 'jeering' look towards me, my heart broke. Thus came the final blow and the worn-out string which bound me to this cruel world gave way.....

After undergoing so many processes at the hands of ever so many doctors, who ate up my shape and beauty (of course a blessing in disguise) I am now.....

At this moment, the terrifying skeleton stood before my mind's eye. Startled in sleep I dashed my leg against the table—the next moment, the lovely lady, the narrative, the skeleton—all vanished into darkness.

Latest Discoveries

The population of India is at the rate of $2\frac{1}{2}$ people for every square mile—K. V. S. Murty.

The disintegrator is used for ceresan treatment—M. V. R. Somayajulu.

The heifers in the Palayakottai Cattle Farm deliver only male calves—C. S. Krishnaswamy.

The incubation period of tuberculosis is 3—4 days—M. V. R. S.

The alkalinity of the soil is due to the presence of salts in the soil, like sodium bi-sulphate, and is remedied by the application of Epsom salt.

Anemometer is a system of measurement adopted in the animal kingdom. Castor seed is an example of nut.

Ipomea hesperidia is a tuber.

Aristolochia is a fodder grown in the wet-lands.

Phraseology of Agricol

By "GANI"

IT is not quite uncommon to come across certain curious phrases and idioms peculiar to a certain locality or institution. It may sound ludicrous to a stranger, but surely, it does give pleasure to use such phrases in our daily conversations. It is just a pinch of salt to make our chit-chat lively. Not only does it give charm to our talk but also lends fun and humour. If we just peep into the history of the coinage of such words, it will be interesting to note that it has always been prompted by some funny incidents or circumstances. We hear all sorts of malapropisms and 'bottomisms', of course not to speak of the mischievous touch of Mr. Pack who goes about in search of such materials. To be conversant with such phrases and to appreciate them fully, one should be aware of the antecedent or anecdote of each phrase or idiom.

Our college students are not, in any way, lagging behind in this respect. They can well nigh compete with any other institution in minting such phrases and idioms. Here are a few that are in vogue at present—Grade, Zambuck, Kommu, Bussing, Batting, I. P., Commentation, Awardment, Quarrellation, Thiring, Cockroaching, Sheet, C. C., F. Y. M., etc.

But unfortunately I am not aware of the time and origin of most of the above phrases, though I know their usage fully well. Indeed they form the legacy that our predecessors have bequeathed to us. Usually they are not what they were when coined. They have undergone ever so many changes and modifications brought about by the action of time, effort of individuals and the influence of environmental factors.

Enough of this "commentation", lest I should get a "grade" from the Editor, who, I understand, is "bussing" daily to town for the last one week, to purchase two quires of paper to type out the Tatler. Poor man! it seems he is daily getting only "zambuck" and not paper. Try, try and try again, Editor Sahib, but don't "buss"; that's too much of "kommufying".

If we did not trust one another,
We'd all have to live within our incomes.

Is it a Fact ?

(If anyone of our readers is in possession of information, as to the truth or otherwise of these statements and allegations, the Editor will be glad to pass on the information to others)

That Mr. S. Krishnaswamy, wears a *saree* and apes a nautch-girl whenever he is in the heat of discussions ?

That Mr. V. L. N. Sastri attends the college 'physically' and not 'spiritually' ?

That Mr. Krishna Iyer boasts, that but for the lac insect, we would not have got that Gramophone, the 'music-grinder' ?

That Mr. V. L. N. Sastri enquired of a shoe-maker as to the kind of leather of which the shoes are 'composted' ?

That Mr. Janardana Rao feels giddy in his hind leg ?

That Mr. N. Thyagarajan says that castor-oil is a saline purgative used in veterinary practice as an enema to wash the uterus ?

That our Warden sometimes conducts experiments on the electric fan in his office in the Hostel, by keeping it switched on when he is out ?

That Mr. Vincent goes round and round the long-block to collect waste paper to be sent to the Second-front ?

That Mr. Chengappa is an expert at catching crabs using his newly devised method of introducing a rod with a frog at its end, into the hole ?

That the formula of cupric chloride as discovered by Mr. Panicker is CuSO_4 ?

That one of the discoveries made by Mr. Narasimha Rao is 'an amoeba being eaten by a paramecium' ?

That Mr. Nambiar and Mr. Sundaram Pillai have chosen the latrine for discussion ?

That according to Mr. Suryanarayana Murty the evolution of plants is from sporophyte to gametophyte ?

That Mr. Prabhakara Reddi threatens to resign his mess-representativeship every other day ?

That according to Mr. G. Narasimha Rao, Black quarter is a seasonal crop ?

That according to Mr. Janardana Rao, insects come under the big phylum Arachnida ?

That Mr. Suryanarayana Murty takes refuge in the latrine whenever Mr. Sarma comes to his room?

That our Warden has issued orders prohibiting the issue of more than 5 'extras' to Mr. I. L. Narasimha Rao due to scarcity of food-stuffs?

That Mr. Krishna Murty prepares tissue-protein from cigarettes and beedies?

That the Government of Madras has appointed Mr. M. V. R. Somayajulu as the Information Officer of the Agricultural College?

That many of the First Years who had their interview at Coimbatore learned by heart many of the cricket rules, and some, the meaning of batting and bowling?

That Mr. P. A. Srinivasan's hat is sun-proof only when rain-proof cover is put on?

That the inmates of the Orphan Block were relieved of part of their distress when the A. R. P. trench was recently dug before their block?

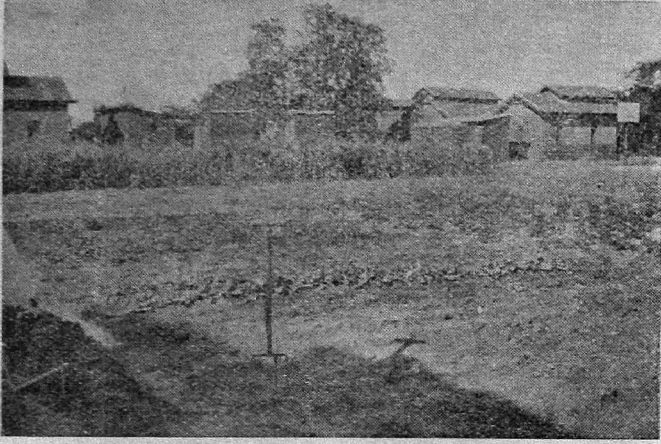

"Grow More Food" Crops of maize and
Vegetables grown by Students.

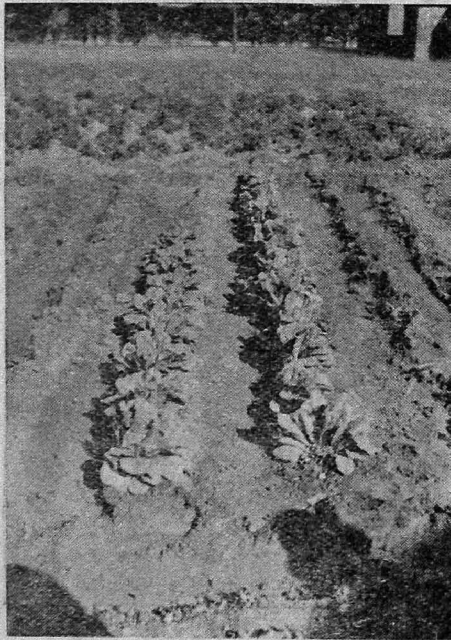

"Grow More Vegetables"—greens
grown by Students".

Improve the method of cultivation,
Discard old practice without hesitation;
Rice and *cholam*, *ragi* in all village,
Be your privilege to grow by tillage.

From well and pond and tank and lake
By every means, water you take
Irrigated crops, do oft give more,
Animal husbandry adds a little more.

Manure you store by methods strange,
Keep it away from weathers' range;
Spinach, plantains, amaranthus, tomato,
For hunger forget not sweet-potato.

If for health we use pounded rice,
The problem of food is solved in a trice;
Comfort you want? do strain and sweat,
Your granary is full—ought be full, I bet.

Potato-sweet, makes for grains deficient,
In stress and strain we keep efficient;
Why cringe your hand—but follow a plan;
Earth divine is there, to help every man.

Oh! brother farmers! of every kind
Grow and eat—do not look behind,
Mother earth is kind to all improvement;
Forward, forward Agricultural Department.

K. Sanjiva Shetty



A military practice was taking place in the country side. The different 'Armies' were making manoeuvres under actual fighting conditions. An old woman unaware of all this, was passing along a road when she came to a bridge that was being guarded by a sentry on duty. When she was about to pass over the bridge, the sentry objected to it. When she asked why, the sentry replied—

"This bridge was blown off by the "Enemy" two days ago".

The old woman could not believe this as the bridge was apparently all right. So she asked another soldier who was passing along that road. He replied.

"Sorry madam, I was killed two days ago."

Four Fingers and a Half

By L. N.

EIGHT P. M. on a cold December night; the black-uniformed guard flashed the green light, and with a lusty whistle the Express commenced her long lonely journey. Passengers were not many that night, and the carriages were practically empty. Myself and another gentleman were the only occupants of a spacious eight-seater. I spread out my bed, and took my seat near the window. The gentleman opposite sat with his hands buried in the ample folds of his huge coat collar. His head was bent with chin resting on his chest. "A morose oily fellow", I muttered to myself. As the wind was raw and cold, I put on my 'monkey-cap' and obeying a primitive impulse peered out into the open to enjoy the beauty of the city environs by the night. The sight was fascinating. The electric lights, scattered far and wide, seemed to exult in wild delight, and I fancied, I even heard them scaring and shouting away at the pressing darkness.

Soon the gaiety and glamour of the city vanished and the train hurled itself into the vast blackness. It was newmoon night, and the occasional red flashes from the engine room throwing lurid glows on the open waste made the 'darkness plainly visible'. With a sigh I turned my eyes to my immediate neighbourhood inside the cosy compartment. My silent partner was still in the same posture. "Rubbish"! I said to myself, and taking the 'Hindu' a copy of which I secured at the book-stall on the platform attempted reading for a diversion. But the jolting caused by the rumbling of the rolling stock made it a sorry affair. Sleeping was out of the question though there was plenty of room available, because to oblige an over-solicitous friend in the city I had taken a cup of strong 'Madras coffee', late that evening. Talking was the only diversion I could next think of, but I wondered whether the stiff figure opposite me was in a mood for conversation. Reluctantly I grabbed the paper again and looked at the pictures on the last page.

"Any news, sir" asked the gentleman unexpectedly. I looked over, glad to have an opportunity for talking and I saw him studying me closely "Oh not much, but you can have the paper" I answered. "No thanks, I am averse to reading while riding because one can enjoy neither" he said and put aside the paper.

I noticed that his left hand was swathed in a loose white cloth.

Taking out a bakelite case he chose a cigarette and offered me another, which I accepted with thanks. He lighted both as per etiquette and I observed the bandage did not inconvenience him. It was

too loosely tied to be useful as a bandage and too cleverly done-up to be mistaken for anything else.

As if reading my thoughts he smiled and said "you are wondering at the kerchief on my left hand. Is it not? But do you believe in ghosts?"

"Why?" I queried amazed at this abruptness. "Ah" he laughed aloud, "right in the middle of this twentieth century when man is about to overtake nature through marvellous scientific achievements, it does look funny to talk of believing in ghosts. I can quite understand your bewilderment. I am myself a scientist. Nevertheless I do believe in ghosts." He looked at me squinting his eyes.

"I had a personal experience, sir," he continued "and you will see tangible proof of it by and by. Let me narrate".

I was quite puzzled at this eccentric sort of gentleman, nevertheless, I got interested and settled down to hear his narrative.

"Well sir", he resumed, "I am a plant breeder interested in improving the quality and yield of the cotton races. Last year I had to work on a cotton farm in one of the hot dry districts of the Presidency. You know that cotton, unlike paddy, thrives in places where water is scarce. Places without good supply of water throughout the year, I believe, must be uncivilised and the people so crude and primitive in their outlook on life that superstitions do seem to have some truth there.

"One night as dark as this I entered a cotton field at 2 A. M. with the watchman of the farm carrying his lantern. The purpose was to make nocturnal observations on a few selected plants. It was my desire as with most other members of my fraternity to discover some phenomena in the vital activity of the cotton plant that could be offered as a homage at the shrine of truth. The night was sultry and except for the crunching of our heavy tread on the hard soil there was no other sound. I started my observations and was soon absorbed in my studies. Sometime after, I suddenly became aware of a faint cough nearby, I thought it was the watchman and did not worry further. But I heard it again, this time louder, but certainly not from the direction of the watchman. Then in the stillness of the night I heard a clear voice say "Oh! how greedy these plant breeders are." It was not the watchman for I knew he could not talk English. He was startled at the sudden change in my behaviour and looked at me suspiciously. "Did you hear anybody talk?" I asked him doubtfully. "No sir, no one is here" he answered quickly. I now got worried and began to feel nervous. My thoughts changed from science to ghost folklore. I felt a creepy sensation of terror. My fear heightened when I heard a hyaena-like laugh. "Didn't you hear that now" I screamed, catching hold of the watchman in a frenzy.

"Hear what" he said laconically and looked very much puzzled. At first he thought I was unwell, and that I was in the throes of a hysteric fright, but when I repeated my experience and dwelt on the possibility of gnomes and goblins roaming in the midnight, his countenance also fell. The light in his hand was burning bright. As I watched the steady flame I beheld a most uncanny sight. A bare hand as yellow as the light darted out somewhere from the murky gloom and turned the pin of the lamp. The wick lowered and the flame burnt low. The watchman was now visibly agitated. Though he did not see the hand he could not mistake the sudden dimness of the flame and he must have even heard the click of the pin. When I told him I actually saw a hand, he jumped with a scream and flinging away the lantern took to his heels shrieking "ghost, ghost"! I too started to run but felt violently pulled by somebody. This time I could see something which I fancy must be a ghost. I saw a bright human head huge and spherical as the dome on an ancient minaret. It had clear facial features, but the face was so transparent that I could see through it the hazy stars twinkling in the dim horizon beyond. It had no trunk or legs. I could see the face and two hands only. These were suspended in the air in correct proportion relative to one another in position. As I looked on helplessly the sly face winked and smiled. It was mischievous but full of liveliness too, "oh! how greedy you are!" it repeated adjusting itself before me. I was encouraged by the smiling familiarity though its bizarre anatomy kept my fear in full tense.

"Look here" it spoke, "I will show you rare sights in the cotton land but you must promise me not to injure or take away anything. I wish you put your razor and other dissecting appliances into your pocket. Do you promise?"

"Yes" I nodded.

"The next moment I felt I had turned round the corner of a dreary lane and I found myself standing on the threshold of a gorgeous panorama of glorious and splendid exhibits of rare and unusual cottons, the like of which I could never have fancied in my wildest imagination. There were plants bearing cotton in their burst fruits so full and profuse that the stem and branches were completely hidden. There were plants on which I could see beautiful bleached skeins of yarn from the fruits instead of the routine raw cotton, a few with actual woven pieces of cloth in their fruits, and yet a few on which I could see different kinds of cotton fabrics, shirtings, coatings, turban cloths, stuffed in the huge gaping fruits. But the most fascinating of all was a group of plants which had bright coloured raw cotton in their fruits. All the 'vibgyor' colours were there. With such cottons there was no need for dyeing. Bright and fast-coloured *sarees* could be woven from yarns of these rainbow-coloured cottons. The ghost went on explaining; I do not remember what all it said.

But my mind was fixed on the coloured litted fruits. I longed to possess some seeds. I forgot the promise I had made to the devil and in a rash moment I took the razor from my pocket and holding it in my left hand was about to reach for a fruit when I felt a terrific blow descend on the nape of my neck. I reeled and fell down, my left hand gripping the handle of the opened razor. While falling I experienced an agonising pain as though something was cutting away at me.

When I came back to myself it was broad day-light. A group of men were standing around me whispering anxiously. They said I must have swooned in a fit of hysteria and fallen over my razor. They would not believe me when I recounted my ghostly experience. Instead of listening to my account one and all of them looked at my left hand. It was only then I came to know of a grave personal loss. My left thumb was cut and the severed portion was lying a few feet away. A group of ants were hovering about the dead tissue. The cut end was clotted and swollen. The moment I made the discovery I felt a throbbing pain shooting from my amputated finger. It was so severe that I cried like a child. I was taken to a hospital where the injured thumb was attended to. And now, look—”.

He held up his left hand and quietly removed the kerchief which had puzzled me all along. It was apparently healthy and there was no mark of recent injury or wound. But the hand had only four and a half fingers. In the place of the normal thumb was a squat, stubby tissue probably the lower-most phalange. I could see that the deformity was the result of an accident and not congenital.

“Do you believe in ghosts now?” he said gripping my shoulders suddenly and giving me a vicious shake. This was indeed an unexpected turn of events and I got more alarmed not to speak of the pain caused by the grip, when he stood up tightening his hold on me.

The train was slowing down. As I was wondering what would happen next he erected himself and in so doing knocked his head violently on the luggage rack above. Immediately he let go his hold and sat limp in his seat. He stared at me for a while like a man in the moon, and in the stare was the glint of murder. He attempted to smile but it expanded to a hideous grin and the oral muscles did not relax until the train came to a halt at the junction station.

As if awaiting, I hastily rolled up my bed, and stepped out of the compartment. The gentleman with four fingers and a half followed me up to the door and said in a tone of unusual sobriety “Sorry Mr. I don’t know your name, but are you alighting here?”

“No,” I said gingerly as I stepped into the next compartment. “I need a quite undisturbed sleep. That is all.”

The Express resumed her journey.

Obituary

Y. Y. S. S. Narasimhamurty Yerramilli Venkata Satya Surya Subramanya Narasimhamurty, comes of a middle class family of Tadepalligudem in West Godavary District. He joined the Agricultural College in the year 1940. He met with unexpected death due to short illness in the summer of 1942, after passing the Second Year University Examination. He leaves behind his young wife, father, mother, brothers and sisters and a host of friends to bemoan his loss.

Our heart-felt condolences are for his parents and his wife.

Dr. N. R. Rajaratnam Dr. N. R. Rajaratnam, G. M. V. C; P. G. (Edin.) comes of a christian family of the South. He passed out of the Veterinary College, Madras with a diploma. After some years of Government service, he proceeded to England for post-graduate study. He worked in our college for sometime as the Lecturer in Animal Hygiene. A man of very sociable disposition, he was our teacher both in and outside the college. Unfortunately, after his transfer to Saidapet he met with accidental death. He leaves behind his wife, sons, daughters and a host of friends to bemoan his loss. Our most sincere sympathies go to his family in their great loss.

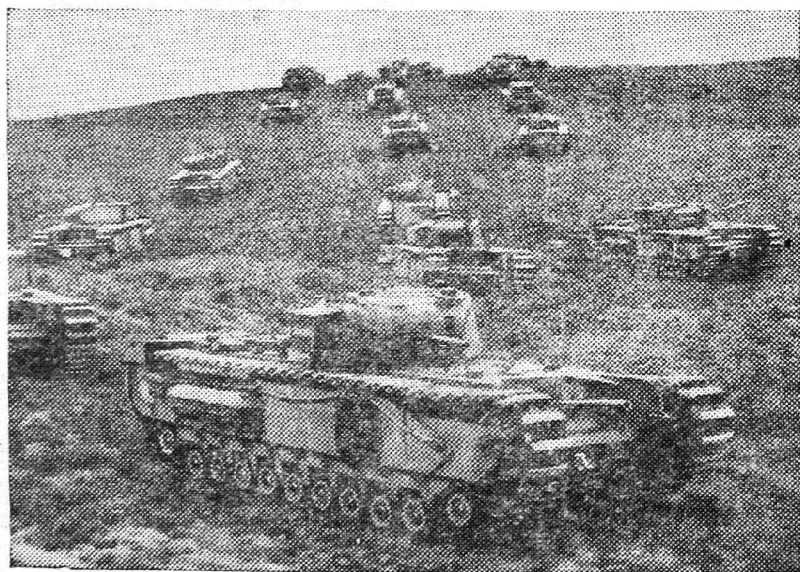

SE 4.

British heavy infantry tanks—Each a small fortress in itself.

"Churchill" heavy infantry tanks—A picture taken on manoeuvres some time ago. The "Churchill" is so strongly armoured that it can be used as a pill-box, but at the same time it possesses a remarkable speed. Six-pounder guns give it a formidable fire-power.