

**A GRAMMAR  
OF  
THE TODA LANGUAGE**

**Dr. S. SAKTHIVEL**  
CENTRE OF ADVANCED STUDY IN LINGUISTICS



**ANNAMALAI UNIVERSITY**  
**ANNAMALAINAGAR**  
TAMILNADU  
INDIA

5

# **A GRAMMAR OF THE TODA LANGUAGE**

**Dr. S. SAKTHIYEL**  
CENTRE OF ADVANCED STUDY IN LINGUISTICS



**ANNAMALAI UNIVERSITY**  
**ANNAMALAINAGAR**  
**TAMILNADU**  
**INDIA**

these people in their own languages, it will be very difficult for us to win over them and to explain the virtues of the social reforms, that we have undertaken. In this era of democracy each individual irrespective of his caste or creed is entitled to have all the comforts and privileges assured by the constitution of India

With all these in view, the Centre of Advanced Study in Linguistics, Annamalai University has undertaken the project 'Descriptive Studies of the Uncultivated Dravidian Languages' and has planned to work on the languages like Kota, Toda, Kasaba, Irula, Paniya and Kattunaicka etc I am immensely pleased that the Centre is able to bringout the present monograph **A Grammar of the Toda Language** by Dr S. Sakthivel. It is my earnest hope that this will be very useful not only to the linguists but also to other social scientists who work on the Todas. I am very happy indeed that we are now able to publish it under the publication programme of the Centre of Advanced Study in Linguistics, Annamalai University

Annamalai University }  
ANNAMALAINAGAR }  
1-2-1977 }

*S. Agesthalingom*  
DIRECTOR  
Centre of Advanced Study in Linguistics

# Preface

The present treatise **A Grammar of the Toda Language** is part of my Ph. D. thesis submitted to the Annamalai University in the year 1974. **Phonology of Toda with Vocabulary** has already been published by the Annamalai University. An ethnological study of the Todas, all the relevant phonological features of this language with examples and vocabulary have been dealt in that treatise. Though several changes were made the inner core remains to be the same. All the relevant morphological features of this language have been studied and examples are also given in this work. A syntactic description of this language is presented here based on the transformational - generative approach.

I owe a debt of deep sense of sincere gratitude and gratefulness to my respected Professor Dr. S. Agesthalingom, Head of the Department of Linguistics and Director, Centre of Advanced Study in Linguistics, Annamalai University for having taught me not only the modern linguistic theories and generative grammar but also guided and helped in all the ways by giving his constructive suggestions, invaluable and stimulating guidance, immense encouragement, sympathetic consideration and personal care which enabled

me to complete this research work and to bring it to the light of the day and also for his kindness in including this work in the publication series of the Centre of Advanced Study in Linguistics, Annamalai University.

I like to express my gratitude to Dr. S. V. Shanmugam, Dr. P. S. Subrahmanyam and Dr. N. Kumaraswami Raja, Readers in Linguistics, Annamalai University for their valuable suggestions. I am grateful to Dr. G. Srinivasa Varma, Mr. T. Edward Williams, Dr. R. Balakrishnan and Mr. N. Rajasekharan Nair for having helped me in one way or other in the course of my research work. I am grateful to Mr. G. Sankaranarayanan and P. Muthuswamy Pillai for correcting the proofs.

I wish to express my gratitude to Dr. S. Chandrasekhar, Vice - Chancellor and the authorities of the Annamalai University for having given me the facilities to accomplish this work, to the University Grants Commission for the generous grants for the publication of this book through the Centre of Advanced Study in Linguistics and to M/s Sri Velan Press, Chidambaram who executed the printing work neatly.

*S. Sakthivel*

# Abbreviations

Abl.	Ablative	Gen.	Genitive
Acc.	Accusative	G. N.	Gender-number
Adj.	Adjective	Hort.	Hortative
Adv.	Adverb	Imper.	Imperative
Adv <sub>l</sub> .	Adverb of limit	Incl.	Inclusive
Adv <sub>man</sub> .	Adverb of manner	Ins.	Instrumental
Adv <sub>part</sub> .	Adverb of particle	Inter.	Interrogative
Adv <sub>t</sub> .	Adverb of time	Intr.	Intransitive
Aux.	Auxiliary	L.	Names of length (measure)
Caus.	Causative	Loc.	Locative
Cl.	Clitics	M.	Names of measure
Cond.	Conditional	M. adj.	Mass adjective
Conj	Conjunctive	Mas.	Masculine
Dat.	Dative	N.	Noun
Decl.	Declarative	N <sub>A</sub> .	Animate noun
Dem.	Demonstrative	N <sub>da</sub> .	Names of day
Desi.	Desiderative	Neg.	Negative
DPN.	Demonstrative pronoun	Neut.	Neuter
Dubi.	Dubitative	N <sub>IA</sub> .	Inanimate noun
Encl.	Enclitics	N <sub>mon</sub> .	Names of months
Ex.	Example	NP.	Noun phrase
Excl.	Exclusive	Num.	Numeral
Fem.	Feminine	Obj.	Object
Frac	Fraction	Obl.	Obligatory

Opt.	Optional	S.	Sandhi rule [in Sandhi]
Ord.	Ordinal	S.	Sentence [in Syntax]
Part.	Particle	Sfx	Suffix
PDPN	Proximate demonstrative pronoun	Sg.	Singular
Perm.	Permissive	Soc.	Sociative
Pers. sfx.	Personal suffix	St	Stem
Pl	Plural	Tem.	Temporal
PN.	Pronoun	Ten.	Tense
P.N.	Participial noun	TM.	Time expression
PPN.	Personal pronoun	Tr.	Transitive
Pres.	Present tense	V. N.	Verbal noun
Proh.	Prohibitive	Voc.	Vocative
RDPN	Remote demonstrative pronoun	Vol.	Voluntative
R. P.	Relative participle	V. P.	Verbal participle
		VP.	Verb phrase

# Contents

1. Introduction	...	1
2. Sandhi	...	9
3. Nouns	...	31
4. Verbs	...	75
5. Appellative verbs	...	157
6. Clitics	...	161
7. Particles	...	175
8. Echo words	...	185
9. Syntax	...	187
Bibliography	...	301

# 1

## Introduction

The Todas are a small tribal community in the Nilgiris, speaking the Toda language and they are wellknown to anthropologists for the aberrancy of their buffalo centred culture. The Todas call their language as *o:ʔ fo:ʃ*. Much work has been done on ethnological studies of Todas but very little work in linguistics is available on the Toda language. According to the 1971 Census of India, the language is spoken by a total of 930 persons

Bernhard Schmid (1837) regarded Toda language as a member of the Dravidian family or more exactly as a relative of Tamil<sup>1</sup>. Robert Caldwell (1856) in the first edition of

---

1 'On the Dialect of the Todavers, the aborigines of the Neelgherries', *Madras Journal of Letters and Science*, Vol. v, p. 155-8, 1837.

'A Comparative Grammar of the Dravidian or South Indian family of languages' accepted this view on the basis of vocabulary and short sentences<sup>2</sup>. Grierson (1905) also endorses this view<sup>3</sup>. Ruckert (1848) holds that the Toda language has a remarkable analogy with the Tartar dialect. Shortt (1868) in his book embodying 'An Account of tribes on the Nilgiris' has recorded as follows: 'The language of the tribe on the Nilgiris is unmistakably Tamil although what is now spoken is a mixed dialect being a jargon of Tamil and Canarese'<sup>4</sup>. Aiyappan (1948) says that 'the language of the Toda is definitely connected with Tamil rather than with Kannada'<sup>5</sup>.

Metz (1864), one of the earliest persons to come into contact with Todas holds the view that it is a dialect of Canarese<sup>6</sup>. G. U. Pope (1873) says that it is a kind of Old Kanarese. As regard the structure of language, he points out,

"The Toda language has no compositions, written or unwritten, not a ballad nor a scrap of anything to indicate

---

2 Caldwell, R. *A Comparative Grammar of the Dravidian or South Indian family of languages*, p. 15, 1856.

3 Grierson, G. A. *Linguistic Survey of India*, Vol. iv, p. 283, 1906

4 Shortt, J. *An Account of tribes on the Nilgiris*, 1868.

5 Aiyappan, A. *Report on the Socio-economic conditions of the Aboriginal tribes in the province of Madras*, 1948.

6 Metz, J. F. 'A Vocabulary of the Dialect spoken by the Todas of the Nilgiri mountains', *Madras Journal of Letters and Science*, i) p 103-8, 131-46, 1856-57; ii) p. 1-24, 1857

intellectual activity. The Tudas, like their buffaloes, are fine animals; but they are least cultivated of the Dravidian races. No trace remains of the employment by them of any written character; it is probable, therefore, that they separated from the other Dravidians before the 'ur-sprache' of those tribes was reduced to writing.

This language, of which but a very scanty fragment remains in use, has more sounds than any other Dravidian dialect, and some of those are peculiar to it, seeming to have been modified by the position and habits of the tribe.

The Tuda chiefly converse in the open air, calling to each other from one breezy hill top to another. Their speech sounds like Old Kanarese spoken in the teeth of a gale of wind.

The Tudas is a language which was once highly inflectional; but having lost most of its inflections, the people who have evidently degenerated in every way as the result of isolation, have not replaced them by significant particle or auxiliaries to the same extent as the other South Indian tribes and the language has thus dwindled down to a mere skeleton. It now barely suffices for the purposes of a very barbarous people.

The language seems to have been originally Old Kanarese, and not a distinct dialect. The Tudas were probably immigrants from the Kanarese Country; and have dwelt on the Nilgiris for about 800 years. Their language was Old Kanarese. A few Tamil forms were introduced by Poligars. Intercourse with the Badagas has probably modernized a few of the forms and introduced some words. Telugu influences

I see no trace. Nor can I trace any resemblance in Tuda to Malayalam, in any of the position where the dialects differs from its sisters"<sup>7</sup>. Robert Caldwell in his second edition (1875) quoted and apparently approved this view<sup>8</sup>. The Nilgiri District Manual furnishes these information on Toda speech. The Toda language is by no means confined to use by Todas alone as was once thought to be, It is a dialect of Old Canarese and closely allied to other Dravidian languages of the plains

W. H. R Rivers (1906) in his monumental work '*The Todas*, has tried to show that there is an affinity between Toda and Malayalam

Dr Oppert holds the view that the Toda is probably allied to Telugu than any other southern dialects

According to Henry Harkness Toda language has no affinity with Sanskrit. According to Prince Peter of Greece (1951) it is related to Sumerian language. This is based on the coincidence he found in the names of gods between the Sumerian and Toda

Among the Dravidian languages modern Malayalam alone has lost its inflections for number and person in the verb, whereas Toda has such inflections with forms that are of the

---

7 Pope, G U 'A Brief outline of the Grammar of the Tuda language', In *Phrenologists amongst the Todas*, p. 239-269, 1873.

8 Caldwell, R. *A Comparative Grammar of the Dravidian or South Indian family of Languages* (Second Edition), p. 512, 1875.

general type. Verb forms without personal endings first appeared in Malayalam records at the end of the 9th century. Toda had been separated from Malayalam before that time. We can see a contrast between Malayalam developments of  $*nk > n̄n̄$ ,  $n̄c > n̄ñ$ ,  $*nr > n̄n̄$ ,  $*nt > nn$  and Toda development of a cluster made up of homorganic nasal plus stop to voiced stop (losing the nasal)

Eg	Ta.	<i>pa mbu</i>	To	<i>po·b</i>	( <i>mb &gt; b</i> )
	Ta	<i>vant-</i>	To	<i>pod</i>	( <i>nt &gt; d</i> )
	Ta.	<i>tiṅr-</i>	To.	<i>tīḍ</i>	( <i>n̄r &gt; ḍ</i> )
	Ta	<i>kaṅt-</i>	To.	<i>koḍ</i>	( <i>nt &gt; ḍ</i> )

Malayalam diverged as a separate language from Tamil from the early Middle Tamil age. Palatalization of initial  $*k$  took place before the front vowels  $i, e$  except when the vowel is followed by a retroflex  $t, n, l$  and  $r$ . Toda does not show palatalization of PDr.  $*k$  before front vowels while PDr.  $*c$  changes as  $t$  in Toda. So we can say that Toda is not a Tamil-Malayalam dialect.

To say that it is a dialect of Telugu is also geographically implausible. Toda does not show palatalization of PDr.  $*k$  before front vowels but Telugu shows this from the earliest records. Another specific feature of Telugu is metathesis but Toda shows nothing of this. Telugu past tense formation is simple. Most of the Telugu words end in vowels whereas most of the Toda words end in consonants. So, Toda is not a dialect of Telugu.

Kannada is the only South Dravidian language which has an innovation of the replacement of  $p > h$  systematically and thoroughly.

Eg.	<i>pa:lu</i>	>	<i>ha:lu</i>	'milk'
	<i>pa:tu</i>	>	<i>ha:ɖu</i>	'to sing'
	<i>po:lu</i>	>	<i>ho:lu</i>	'to be alike'

Toda uses the root *ta-* to give (first or second person) as indirect object, *kotu* when there is a third person as indirect object. Kannada in its earliest records did not make this distinction. The morphological evidence of the sibilant past tense suffix and phonological matter of *rr* are clear indications that Toda was already going its own way as a language at least as early as the earliest Kannada records. Kannada uses aspirates as phonemes but Toda does not. *i/e* and *u/o* alternation are not found in Toda language whereas it operates in Tamil, Malayalam, Kannada and Telugu. If Toda preserves a proto-Dravidian feature and Old Kannada does not, Toda might derive from Proto-Dravidian or from any language that preserves the Proto-Dravidian feature. There is no doubt that many words of Kannada origin can be traced in this language, when they speak with other tribes. Such words may be accounted for by their long intercourse with the Badagas who are of Kanarese stock. Moreover many words of quite common use cannot be traced to any other language of the neighbours. Prof. M B Emeneau has concluded 'we have really no right to class Toda as a dialect of Kannada rather than as a dialect of some other South Dravidian or as an independent language'<sup>9</sup>

Toda is not a dialect of any of the important languages that are its neighbours, Tamil, Malayalam and Kannada but it is an independent language of the Dravidian family.

9 Emeneau, M B "Toda, A Dravidian language", *Transactions of the Philological Society*, p. 34, 1957.

Todas live at the meeting place of Tamil, Malayalam and Kannada languages but owing to their isolated position their language is not a blend of these but has very definite and distinct characteristics of its own, as might be expected from the character of the people. Todas, Kotas and Badagas live together and have lived together for centuries, even though three mutually unintelligible languages are spoken. Generally Nilgiri languages have been almost isolated geographically from all other South Dravidian languages. Toda is in fact a descendant of an off shoot from Proto-Tamil which is of course the ancestor of both Tamil and off-shoot from Malayalam. Toda belongs with Tamil - Malayalam rather than with Kannada.

One evidence to sub-grouping of Toda-Kota Nilgiri sub-group does not share palatalization of *k-* before front vowels we must posit that the splitting off the Nilgiri sub-group took place before the Tamil palatalization. These two languages disagree with the other South Dravidian languages in having South Dravidian past stem for both past and non-past. This must be interpreted as an innovation shared in common by these two languages and since such deep seated borrowing is implausible unless other evidences necessitate the assumption. Bh. Krishnamurti has made it clear that Toda and Kota share a common innovation in the oblique forms of the first person pronoun exclusive and inclusive<sup>10</sup>. In both the languages alveolar plosive is preserved. There is a deep lying identity in the phonological and grammatical structures of Kota and Toda. Separation of Pre-Toda and Kota took

10 Krishnamurti, Bh. 'Dravidian personal pronoun', *Studies in Indian Linguistics*, p. 189-205, Poona and Annamalainagar, 1968.

place before the Tamil palatalization reached their place of origin *i.e.* probably at the period round about the beginning of the Tamil recorded texts.

One of the most striking features of Toda is the loss of vowels in non-initial syllables. Toda could be classed with the southern languages alone, since they have alveolar phonemes distinguished from dentals and retroflexes. Toda morphology is different in many respects from that of any other of the language. Secondary stem (termed as  $S_2$ ) is the basis for the past tense but in Toda it is the basis for the past and non-past. Toda is the only language which retains in full working order as part of the past tense formation the sibilant suffix that must be reconstructed as part of the past tense apparatus for Proto-Dravidian.

**Phonology of Toda with Vocabulary** has already been published by the Annamalai University<sup>11</sup>. An ethnological study of the Todas, all the relevant phonological features of this language with examples and Vocabulary have been presented in that treatise.

---

11 Sakthivel, S. *Phonology of Toda with Vocabulary*, (DLP 41), Annamalai University, 1976.

# 2

## Sandhi

2.0. Internal Sandhi, occurring within a word bounded by pause is alone discussed in this chapter. In this chapter the ampersand '&' is used to represent the morpheme boundary and the '-' is used to indicate the place of the phoneme in question. The Sandhi rules are referred to in the following chapters. These rules are ordered and in cases where two or more rules operate, they operate one after another in the order in which they are given.

$$2.1. \quad t \longrightarrow t / \left\{ \begin{array}{l} l \\ n \end{array} \right\} \& -$$

$$u:l \& t \quad (\text{Sources 4.1.1.2}) \quad \longrightarrow \quad u:l \& t$$

$$tu:l \& t \quad (4.1.1.2) \quad \longrightarrow \quad tu:l \& t$$

<i>pī:l</i> & <i>t</i>	(4.1.1.2)	—>	<i>pī:l</i> & <i>t</i>
<i>pu:l</i> & <i>t</i>	(4.1.1.2)	—>	<i>pu:l</i> & <i>t</i>
<i>kiskwīl</i> & <i>t</i>	(4.1.1.2)	—>	<i>kiskwīl</i> & <i>t</i>
<i>ni:l</i> & <i>t</i>	(4.1.1.2)	—>	<i>ni:l</i> & <i>t</i>
<i>pe:l</i> & <i>t</i>	(4.1.1.2)	—>	<i>pe:l</i> & <i>t</i>
<i>ko:n</i> & <i>t</i>	(4.1.1.2)	—>	<i>ko:n</i> & <i>t</i>

2.2.  $\left\{ \begin{array}{l} l \\ n \end{array} \right\} \longrightarrow \emptyset / - \& t$

<i>u:l</i> & <i>t</i>	(S.2.1)	—>	<i>u:t</i>
<i>tu:l</i> & <i>t</i>	(S.2.1)	—>	<i>tu:t</i>
<i>pī:l</i> & <i>t</i>	(S.2.1)	—>	<i>pī:t</i>
<i>pu:l</i> & <i>t</i>	(S.2.1)	—>	<i>pu:t</i>
<i>kiskwīl</i> & <i>t</i>	(S.2.1)	—>	<i>kiskwīt</i>
<i>ni:l</i> & <i>t</i>	(S.2.1)	—>	<i>ni:t</i>
<i>pe:l</i> & <i>t</i>	(S.2.1)	—>	<i>pe:t</i>
<i>ko:n</i> & <i>t</i>	(S.2.1)	—>	<i>ko:t</i>

2.3.  $t \longrightarrow \left[ \begin{array}{c} k \\ p \\ t \\ t \end{array} \right] / \left[ \begin{array}{c} \{x\} \\ \{g\} \\ b \\ \{d\} \\ \{r\} \\ \{t\} \\ \{l\} \end{array} \right] \& -$

<i>alx</i> & <i>t</i>	(4.1.1.2)	—>	<i>alx</i> & <i>k</i>
<i>ī:x</i> & <i>t</i>	(4.1.1.2)	—>	<i>ī:x</i> & <i>k</i>

$oḍg & t$	(4.1.1.2)	$\rightarrow$	$oḍg & k$
$tīrb & t$	(4.1.1.2)	$\rightarrow$	$tīrb & p$
$o:d & t$	(4.1.1.2)	$\rightarrow$	$o:d & t$
$ku:r & t$	(4.1.1.2)	$\rightarrow$	$ku:r & t$
$ni:r & t$	(4.1.1.2)	$\rightarrow$	$ni:r & t$
$mo:r & t$	(4.1.1.2)	$\rightarrow$	$mo:r & t$
$tō:r & t$	(4.1.1.2)	$\rightarrow$	$tō:r & t$
$no:l & t$	(4.1.1.2)	$\rightarrow$	$no:l & t$

2.4.

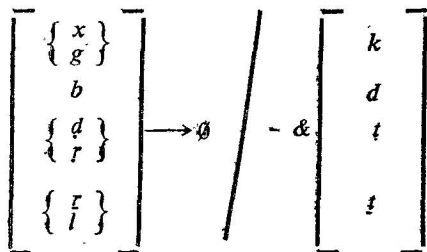

$alx & k$	(S.2.3)	$\rightarrow$	$alk$
$tī:x & k$	(S.2.3)	$\rightarrow$	$tī:x$
$oḍg & k$	(S.2.3)	$\rightarrow$	$oḍk$
$wīrg & k$	(S.2.3)	$\rightarrow$	$wīrk$
$tīrb & p$	(S.2.3)	$\rightarrow$	$trīp$
$o:d & t$	(S.2.3)	$\rightarrow$	$o:t$
$ku:r & t$	(S.2.3)	$\rightarrow$	$ku:t$
$ni:r & t$	(S.2.3)	$\rightarrow$	$ni:t$
$mo:r & t$	(S.2.3)	$\rightarrow$	$mo:t$
$tō:r & t$	(S.2.3)	$\rightarrow$	$tō:t$
$no:l & t$	(S.2.3)	$\rightarrow$	$no:t$

$$2.5. \quad p \longrightarrow f / \left\{ \begin{array}{c} \bar{i} \\ t \end{array} \right\} - \& V$$

$\bar{i} \& po\theta$  (3.6.2.1)  $\longrightarrow \bar{i} \& fo\theta$

$\bar{o}t \& po\theta$  (3.6.8.2)  $\longrightarrow \bar{o}t \& fo\theta$

$$2.6. \quad p \longrightarrow \emptyset / \left\{ \begin{array}{c} r \\ w \end{array} \right\} - \& V$$

$ar \& po\theta$  (3.6.6.1)  $\longrightarrow ar\theta\theta$

$\bar{o}w \& po\theta$  (3.6.7.2)  $\longrightarrow \bar{o}wo\theta$

$$2.7. \quad m \longrightarrow \emptyset / - \& \left\{ \begin{array}{c} t \\ x \end{array} \right\}$$

$sonm \& t \& k$  (3.2.2.4)  $\longrightarrow son \& t \& k$

$no:ym \& t \& k$  (3.2.2.4)  $\longrightarrow no:y \& t \& k$

$k\bar{i}nm \& t \& k$  (3.2.2.4)  $\longrightarrow k\bar{i}n \& t \& k$

$pojo:rm \& t \& \underline{gn}$  (3.2.2.5)  $\longrightarrow pojo:r \& t \& \underline{gn}$

$po\eta m \& xo:rn$  (3.7.1.1)  $\longrightarrow po\eta \& xo:rn$

$tw\bar{i}:tm \& xo:rn$  (3.7.1.1)  $\longrightarrow tw\bar{i}:t \& xo:rn$

$$2.8. \quad r \longrightarrow t / - \& k$$

$k\bar{o}:r \& k$  (3.2.2.4)  $\longrightarrow k\bar{o}:t \& k$

$$2.9. \quad \bar{t} \longrightarrow l / - \& \left\{ \begin{array}{c} c \\ f \end{array} \right\}$$

$ka\bar{t} \& c$  (4.1.1.1)  $\longrightarrow kal \& c$

- twī:l̥ & c* (4.1 1.1)  $\rightarrow$  *twī:l & c*  
*kaṭ & fy* (4 2.4)  $\rightarrow$  *kaḷ & fy*
- 2 10.  $\bar{t} \rightarrow n / - \& m.$   
*naṭ & my* (3.7 5)  $\rightarrow$  *nan & my*
- 2.11  $r \rightarrow ḍ / - \& c$   
*kōṛ & c* (4.1.1 1)  $\rightarrow$  *kōḍ & c*
- 2 12  $\bar{d} \rightarrow r / - \& \left\{ \begin{matrix} t \\ f \end{matrix} \right\}$   
*ōḍ & t* (4.1.1.2)  $\rightarrow$  *ōṛ & t*  
*kaḍ & t* (4.1.1.2)  $\rightarrow$  *kaṛ & t*  
*ōḍ & f* (4 1.1.2)  $\rightarrow$  *ōṛ & f*
- 2 13.  $sō.r \rightarrow sō: / - \& t$   
*sō.r & t* (4.1.1.2)  $\rightarrow$  *sō:t*
- 2 14.  $\underline{s} \rightarrow \check{s} / y \& -$   
*poḥy & \underline{s}* (3 2 2.7)  $\rightarrow$  *poḥy & \check{s}*  
*kulo:y & \underline{s}* (3 2 2.7)  $\rightarrow$  *kulo:y & \check{s}*  
*aḍy & \underline{s}* (3 2 2 7)  $\rightarrow$  *aḍy & \check{s}*  
*po:y & \underline{s}* (3 2.2.7)  $\rightarrow$  *po:y & \check{s}*  
*kīy & \underline{s}* (4 11.2 1)  $\rightarrow$  *kīy & \check{s}*  
*i ṣkity & \underline{s} & n* (3 2 2 5)  $\rightarrow$  *i.ṣkity & \check{s} & n*  
*koce:ry & \underline{s} & n* (3 2.2.5)  $\rightarrow$  *koce:ry & \check{s} & n*

$$2.15. \quad s \longrightarrow s \left\{ \begin{array}{c} \text{t} \\ \text{d} \\ \text{n} \\ \text{r} \end{array} \right\} \& \text{---}$$

<i>uṭ</i> & <i>s</i>	(3.2.2.7)	—>	<i>uṭ</i> & <i>s</i>
<i>uṭ</i> & <i>s</i> & <i>n</i>	(3.2.2.5)	—>	<i>uṭ</i> & <i>s</i> & <i>n</i>
<i>wī:d</i> & <i>s</i>	(4.11.2.1)	—>	<i>wī d</i> & <i>s</i>
<i>uṇ</i> & <i>s</i>	(4.11.2.1)	—>	<i>uṇ</i> & <i>s</i>
<i>naṛ</i> & <i>s</i>	(4.11.2.1)	—>	<i>naṛ</i> & <i>s</i>

$$2.16. \quad s \longrightarrow z / \bar{i} : \& \text{---}$$

<i>twī: &amp; s</i>	(3.2.2.7)	—>	<i>twī: &amp; z</i>
---------------------	-----------	----	---------------------

$$2.17 \quad n \longrightarrow n \left\{ \begin{array}{c} \text{t} \\ \text{d} \\ \text{s} \\ \text{z} \\ \text{n} \\ \text{t} \\ \text{i} \end{array} \right\} \& \text{---}$$

<i>pe:t</i> & <i>n</i>	(3.1.1.1)	—>	<i>pe.t</i> & <i>n</i>
<i>pī:t</i> & <i>n</i>	(3.1.1.1)	—>	<i>pī.t</i> & <i>n</i>
<i>kof:d</i> & <i>n</i>	(3.1.1.1)	—>	<i>kof.d</i> & <i>n</i>
<i>wī:d</i> & <i>n</i>	(3.1.1.1)	—>	<i>wī.d</i> & <i>n</i>
<i>e:t</i> & <i>n</i>	(3.1.1.1)	—>	<i>e.t</i> & <i>n</i>

<i>no:s &amp; n</i>	(3.1.1.1)	—>	<i>no:s &amp; n</i>
<i>o:ř &amp; n</i>	(3.2.2.1)	—>	<i>o:ř &amp; n</i>
<i>kol &amp; n</i>	(4.2.2.5)	—>	<i>kol &amp; n</i>
<i>uř &amp; s &amp; n</i>	(S.2.15)	—>	<i>uř &amp; s &amp; n</i>

2.18.  $c_1 \longrightarrow \emptyset / c_1 \& \text{—}$   
 where  $c_1$  is nasal or sibilant.

<i>en &amp; n</i>	(3 2 2 6)	—>	<i>en</i>
<i>nin &amp; n</i>	(3.2.2.6)	—>	<i>nin</i>
<i>pīrs &amp; s &amp; pin &amp; i</i>	(4 3.1.2.2)	—>	<i>pīrs &amp; pin &amp; i</i>
<i>ars &amp; s &amp; pin &amp; i</i>	(4 3 1.2 2)	—>	<i>ars &amp; pin &amp; i</i>
<i>pe:s &amp; s &amp; pin &amp; i</i>	(4.3.1 2 2)	—>	<i>pe:s &amp; pin &amp; i</i>
<i>kīs &amp; s &amp; pin &amp; i</i>	(4.3.1 2.2)	—>	<i>kīs &amp; pin &amp; i</i>
<i>paš &amp; še &amp; pin &amp; i</i>	(4 6 1)	—>	<i>paš &amp; e &amp; pin &amp; i</i>
<i>taš &amp; še &amp; pin &amp; i</i>	(4.6 1)	—>	<i>taš &amp; e &amp; pin &amp; i</i>
<i>paš &amp; š &amp; pin &amp; i</i>	(4.7 1)	—>	<i>paš &amp; pin &amp; i</i>
<i>taš &amp; š &amp; pin &amp; i</i>	(4.7.1)	—>	<i>taš &amp; pin &amp; i</i>

2.19.  $\left\{ \begin{matrix} i: \\ n \end{matrix} \right\} \longrightarrow \emptyset / \text{—} \& a:$

<i>eyi: &amp; a:</i>	(3 2 2.9)	—>	<i>ey &amp; a:</i>
<i>okn &amp; a:</i>	(3 2 2 9)	—>	<i>ok &amp; a:</i>

2.20.  $\left\{ \begin{matrix} c \\ j \end{matrix} \right\} \longrightarrow \left\{ \begin{matrix} č \\ j \end{matrix} \right\} / \text{—} \& y$

(Rules 2.20 - 2.40 operate in the secondary stem formation (S<sub>2</sub>))

<i>kī:c &amp; y</i>	(Sources 4.3)	—>	<i>ki:č &amp; y</i>
<i>monc &amp; y</i>	(4.3)	—>	<i>monč &amp; y</i>
<i>naɖc &amp; y</i>	(4.3)	—>	<i>naɖč &amp; y</i>
<i>müc &amp; y</i>	(4.3)	—>	<i>müč &amp; y</i>
<i>ti:rc &amp; y</i>	(4.3)	—>	<i>ti rč &amp; y</i>
<i>ni:j &amp; y</i>	(4.3)	—>	<i>ni j &amp; y</i>
<i>oj &amp; y</i>	(4.3)	—>	<i>oj &amp; y</i>
<i>pu:j &amp; y</i>	(4.3)	—>	<i>pu:j &amp; y</i>
<i>pīɖj &amp; y</i>	(4.3)	—>	<i>pīɖj &amp; y</i>
<i>mo:j &amp; y</i>	(4.3)	—>	<i>mo:j &amp; y</i>

2.21.  $y \longrightarrow \emptyset / \left\{ \begin{array}{c} \check{c} \\ j \end{array} \right\} \& -$

<i>ki:č &amp; y</i>	(S.2.20)	—>	<i>krč</i>
<i>monč &amp; y</i>	(S.2.20)	—>	<i>monč</i>
<i>naɖč &amp; y</i>	(S.2.20)	—>	<i>naɖč</i>
<i>müč &amp; y</i>	(S.2.20)	—>	<i>müč</i>
<i>tī:rč &amp; y</i>	(S.2.20)	—>	<i>ti:rč</i>
<i>ni:j &amp; y</i>	(S.2.20)	—>	<i>ni:j</i>
<i>oj &amp; y</i>	(S.2.20)	—>	<i>oj</i>
<i>pu:j &amp; y</i>	(S.2.20)	—>	<i>pu:j</i>
<i>pīɖj &amp; y</i>	(S.2.20)	—>	<i>pīɖj</i>
<i>mo:j &amp; y</i>	(S.2.20)	—>	<i>mo:j</i>

2.22.  $\emptyset \longrightarrow s / y \ \& \ -$

<i>mi:y &amp; ∅</i>	(4.3)	→	<i>mi:y &amp; s</i>
<i>kīy &amp; ∅</i>	(4.3)	→	<i>kīy &amp; s</i>
<i>mūry &amp; ∅</i>	(4.3)	→	<i>mūry &amp; s</i>
<i>ary &amp; ∅</i>	(4.3)	→	<i>ary &amp; s</i>
<i>kwīy &amp; ∅</i>	(4.3)	→	<i>kwīy &amp; s</i>

2.23  $r \longrightarrow \emptyset / - \ \& \ \emptyset$

<i>pī:rfor &amp; ∅</i>	(4.3)	→	<i>pī:rfo∅</i>
<i>kō r &amp; ∅</i>	(4.3)	→	<i>kō:∅</i>
<i>o: r &amp; ∅</i>	(4.3)	→	<i>o:∅</i>

2.24.  $\left[ \begin{array}{c} idy \\ soy \end{array} \right] \longrightarrow \left[ \begin{array}{c} id \\ so \end{array} \right] / - \ \& \ t$

<i>idy &amp; t</i>	(4.3)	→	<i>idt</i>
<i>soy &amp; t</i>	(4.3)	→	<i>sot</i>

2.25.  $t \longrightarrow c / y \ \& \ -$

<i>twī:y &amp; t</i>	(4.3)	→	<i>twī:y &amp; c</i>
<i>mony &amp; t</i>	(4.3)	→	<i>mony &amp; c</i>
<i>uny &amp; t</i>	(4.3)	→	<i>uny &amp; c</i>
<i>ary &amp; t</i>	(4.3)	→	<i>ary &amp; c</i>
<i>kary &amp; t</i>	(4.3)	→	<i>kary &amp; c</i>
<i>pīry &amp; t</i>	(4.3)	→	<i>pīry &amp; c</i>
<i>pa:y &amp; t</i>	(4.3)	→	<i>pa:y &amp; c</i>

2.26.  $y \rightarrow \emptyset$  / — & {  $\begin{matrix} t \\ k \\ f \\ c \\ V \\ sib \end{matrix}$  }

$V$  stands for vowel  
 $sib$  stands for sibilant

<i>nwī.ty &amp; o &amp; t &amp; i</i>	(4.4.1)	→	<i>nwī t &amp; o &amp; t &amp; i</i>
<i>nwī:ty &amp; o &amp; ʒ &amp; i</i>	(4.4.1)	→	<i>nwī:t &amp; o &amp; ʒ &amp; i</i>
<i>ürpy &amp; t</i>	(4.3.1.1.3)	→	<i>ürp &amp; t</i>
<i>öšty&amp;kīʒ&amp;o&amp;en&amp;i</i>	(4.17.1)	→	<i>öšt&amp;kīʒ&amp;o&amp;en&amp;i</i>
<i>nwī:ty&amp;kīʒ&amp;o&amp;en&amp;i</i>	(4.17.1)	→	<i>nwī:t&amp;kīʒ&amp;o&amp;en&amp;i</i>
<i>öšty&amp;kīʒ&amp;o&amp;p&amp;i</i>	(4.17.1)	→	<i>öšt&amp;kīʒ&amp;o&amp;p&amp;i</i>
<i>öšty &amp; ø &amp; foy</i>	(4.12.2)	→	<i>öšt &amp; ø &amp; foy</i>
<i>noky &amp; ø &amp; foy</i>	(4.12.2)	→	<i>nok &amp; ø &amp; foy</i>
<i>twī:y &amp; c</i>	(S.2.25)	→	<i>twī:c</i>
<i>mony &amp; c</i>	(S.2.25)	→	<i>monc</i>
<i>uny &amp; c</i>	(S.2.25)	→	<i>unc</i>
<i>ary &amp; c</i>	(S.2.25)	→	<i>arc</i>
<i>kary &amp; c</i>	(S.2.25)	→	<i>karc</i>
<i>pīry &amp; c</i>	(S.2.25)	→	<i>pīrc</i>
<i>pary &amp; c</i>	(S.2.25)	→	<i>parc</i>
<i>mī:y &amp; s</i>	(S.2.22)	→	<i>mī:</i>
<i>kīy &amp; s</i>	(S.2.22)	→	<i>kīs</i>
<i>müry &amp; s</i>	(S.2.22)	→	<i>mürs</i>
<i>aṛy &amp; s</i>	(S.2.22)	→	<i>aṛs</i>
<i>kwīj &amp; s</i>	(S.2.22)	→	<i>kwīs</i>

<i>tūṭy &amp; s &amp; pin &amp; i</i>	(4.3 1.2.2) —>	<i>tūṭ &amp; s &amp; pin &amp; i</i>
<i>noṭy &amp; s &amp; pin &amp; i</i>	(4.3.1.2.2) —>	<i>noṭ &amp; s &amp; pin &amp; i</i>
<i>pīty &amp; s &amp; pin &amp; i</i>	(4.3.1.2.2) —>	<i>pīṭ &amp; s &amp; pin &amp; i</i>
<i>e moṭy &amp; s &amp; pin &amp; i</i>	(4.3.1.2.2) —>	<i>e moṭ &amp; s &amp; pin &amp; i</i>
<i>pīnty &amp; s &amp; pin &amp; i</i>	(4.3.1.2.2) —>	<i>pīnt &amp; s &amp; pin &amp; i</i>
<i>kodṭ &amp; s &amp; pin &amp; i</i>	(4.3.1.2.2) —>	<i>kod &amp; s &amp; pin &amp; i</i>
<i>udṭ &amp; s &amp; pin &amp; i</i>	(4.3.1.2.2) —>	<i>ud &amp; s &amp; pin &amp; i</i>
<i>nwīṭy &amp; s &amp; pin &amp; i</i>	(4.3.1.2.2) —>	<i>nwīṭ &amp; s &amp; pin &amp; i</i>
<i>nīḍy &amp; s &amp; pin &amp; i</i>	(4.3.1.2.2) —>	<i>nīḍ &amp; s &amp; pin &amp; i</i>
<i>koṭy &amp; s &amp; pin &amp; i</i>	(4.3.1.2.2) —>	<i>koṭ &amp; s &amp; pin &amp; i</i>
<i>nīṭy &amp; s &amp; pin &amp; i</i>	(4.3.1.2.2) —>	<i>nīṭ &amp; s &amp; pin &amp; i</i>
<i>puṭy &amp; s &amp; pin &amp; i</i>	(4.3.1.2.2) —>	<i>puṭ &amp; s &amp; pin &amp; i</i>
<i>kufy &amp; s &amp; pin &amp; i</i>	(4.3.1.2.2) —>	<i>kuf &amp; s &amp; pin &amp; i</i>
<i>karky &amp; s &amp; pin &amp; i</i>	(4.3.1.2.2) —>	<i>kark &amp; s &amp; pin &amp; i</i>
<i>kumy &amp; s &amp; pin &amp; i</i>	(4.3.1.2.2) —>	<i>kum &amp; s &amp; pin &amp; i</i>
<i>aṣpy &amp; s &amp; pin &amp; i</i>	(4.3.1.2.2) —>	<i>aṣp &amp; s &amp; pin &amp; i</i>
<i>nob &amp; s &amp; pin &amp; i</i>	(4.3.1.2.2) —>	<i>nob &amp; s &amp; pin &amp; i</i>
<i>tīrky &amp; s &amp; pin &amp; i</i>	(4.3.1.2.2) —>	<i>tīrk &amp; s &amp; pin &amp; i</i>
<i>moṛky &amp; s &amp; pin &amp; i</i>	(4.3.1.2.2) —>	<i>moṛk &amp; s &amp; pin &amp; i</i>
<i>omky &amp; s &amp; pin &amp; i</i>	(4.3.1.2.2) —>	<i>omk &amp; s &amp; pin &amp; i</i>
<i>wa.gy &amp; s &amp; pin &amp; i</i>	(4.3.1.2.2) —>	<i>wa.g &amp; s &amp; pin &amp; i</i>

2.27.  $\left\{ \begin{array}{l} r \\ l \end{array} \right\} \longrightarrow \emptyset / - \& t$

*wīṛ & t* (4.3) —> *wīṭ*

*swī:l & t* (4.3) —> *swī t*

$$2.28. \quad t \longrightarrow \underset{v}{t} / \left\{ \begin{array}{c} r \\ t \end{array} \right\} \& -$$

<i>pīr</i> & <i>t</i>	(4 3)	→	<i>pīr</i> & <i>ṭ</i>
<i>kaṭ</i> & <i>t</i>	(4 3)	→	<i>kaṭ</i> & <i>ṭ</i>
<i>mu:neṭ</i> & <i>t</i>	(4 3)	→	<i>mu:neṭ</i> & <i>ṭ</i>
<i>twī:t</i> & <i>t</i>	(4 3)	→	<i>twī:t</i> & <i>ṭ</i>

$$2.29. \quad t \longrightarrow t / \left\{ \begin{array}{c} d \\ r \\ t \end{array} \right\} \& -$$

<i>wī:rīd</i> & <i>t</i>	(4 3)	→	<i>wī:rīd</i> & <i>ṭ</i>
<i>oṛ</i> & <i>t</i>	(4 3)	→	<i>oṛ</i> & <i>ṭ</i>
<i>ke:ṭ</i> & <i>t</i>	(4.3)	→	<i>ke:ṭ</i> & <i>ṭ</i>

$$2.30. \quad \left[ \begin{array}{c} \left\{ \begin{array}{c} r \\ t \end{array} \right\} \\ \left\{ \begin{array}{c} d \\ r \\ t \end{array} \right\} \end{array} \right] \longrightarrow \emptyset / \left[ \begin{array}{c} t \\ t \end{array} \right] \& -$$

<i>pīr</i> & <i>ṭ</i>	(S.2.28)	→	<i>pī</i> <i>ṭ</i>
<i>kaṭ</i> & <i>ṭ</i>	(S.2.28)	→	<i>ka</i> <i>ṭ</i>
<i>mu:neṭ</i> & <i>ṭ</i>	(S.2.28)	→	<i>mu:ne</i> <i>ṭ</i>
<i>twī.t</i> & <i>ṭ</i>	(S.2.28)	→	<i>twī</i> <i>ṭ</i>
<i>wī.rīd</i> & <i>ṭ</i>	(S.2.29)	→	<i>wī:rī</i> <i>ṭ</i>
<i>oṛ</i> & <i>ṭ</i>	(S.2.29)	→	<i>o</i> <i>ṭ</i>
<i>ke:ṭ</i> & <i>ṭ</i>	(S.2.29)	→	<i>ke</i> <i>ṭ</i>

2.31.  $t \longrightarrow k / x \ \& \ -$

*pux & t* (4.3)  $\longrightarrow$  *pux & k*

2.32.  $x \longrightarrow \emptyset / - \ \& \ k$

*pux & k* (S.2.31)  $\longrightarrow$  *puk*

2.33.  $\left[ \begin{array}{c} \underline{mi} \ y \\ \underline{p\ddot{o}y} \\ \underline{sal} \end{array} \right] \longrightarrow \left[ \begin{array}{c} \underline{mi:} \\ \underline{p\ddot{o}} \\ \underline{sa} \end{array} \right] / - \ \& \ d$

*mi:y & d* (4.3)  $\longrightarrow$  *mi:d*

*poy & d* (4.3)  $\longrightarrow$  *pöd*

*sal & d* (4.3)  $\longrightarrow$  *sad*

2.34.  $r \longrightarrow \emptyset / - \ \& \ d$

*sö:r & d* (4.3)  $\longrightarrow$  *söd*

*u:r & d* (4.3)  $\longrightarrow$  *ud*

2.35.  $d \longrightarrow \underline{d} / \left\{ \begin{array}{c} \underline{s} \\ \underline{n} \\ \underline{l} \end{array} \right\} \ \& \ -$

*kīṣ & d* (4.3)  $\longrightarrow$  *kīṣ & d*

*i n & d* (4.3)  $\longrightarrow$  *i:n & d*

*tīn & d* (4.3)  $\longrightarrow$  *tīn & d*

*te:l & d* (4.3)  $\longrightarrow$  *te:l & d*

*nīl & d* (4.3)  $\longrightarrow$  *nīl & d*

$$236. \quad \left\{ \begin{array}{c} s \\ n \\ l \end{array} \right\} \longrightarrow \emptyset / - \& \underline{d}$$

*kī̄s* & *d* (S 2.35)  $\longrightarrow$  *kī̄d*

*i n* & *d* (S 2.35)  $\longrightarrow$  *i:d*

*tīn* & *d* (S 2.35)  $\longrightarrow$  *tīd*

*te:l* & *d* (S.2.35)  $\longrightarrow$  *te:d*

*nīl* & *d* (S 2.35)  $\longrightarrow$  *nīd*

$$237. \quad d \longrightarrow d / \left\{ \begin{array}{c} n \\ l \end{array} \right\} \& -$$

*uṅ* & *d* (4.3)  $\longrightarrow$  *uṅ* & *d*

*nīl* & *d* (4.3)  $\longrightarrow$  *nī:l* & *d*

*kiskwīl* & *d* (4.3)  $\longrightarrow$  *kiskwīl* & *d*

*pu:l* & *d* (4.3)  $\longrightarrow$  *pu:l* & *d*

$$238. \quad \left[ \begin{array}{c} ko:n \\ por \\ to:r \end{array} \right] \longrightarrow \left[ \begin{array}{c} koṅ \\ por \\ tor \end{array} \right] / - \& d$$

*ko:n* & *d* (4.3)  $\longrightarrow$  *koṅ* & *d*

*por* & *d* (4.3)  $\longrightarrow$  *por* & *d*

*to:r* & *d* (4.3)  $\longrightarrow$  *tor* & *d*

$$239 \quad d \longrightarrow d / koṅ \& -$$

*koṅ* & *d* (S 2.38)  $\longrightarrow$  *koṅ* & *d*

$$240 \quad \left[ \begin{array}{c} \left\{ \begin{array}{c} l \\ n \end{array} \right\} \\ r \end{array} \right] \rightarrow \emptyset / - \& \left[ \begin{array}{c} d \\ d \end{array} \right]$$

*ni:l & d* (S.2.37)  $\rightarrow$  *nī:d*

*kiskwīl & d* (S.2.37)  $\rightarrow$  *kiskwīḍ*

*pu:l & d* (S 2 37)  $\rightarrow$  *pu:d*

*uṅ & d* (S 2 37)  $\rightarrow$  *uḍ*

*koṅ & d* (S 2 39)  $\rightarrow$  *koḍ*

*por & d* (S.2.38)  $\rightarrow$  *pod*

*tor & d* (S 2 38)  $\rightarrow$  *tod*

$$241. \quad \left\{ \begin{array}{c} t \\ \emptyset \\ c \end{array} \right\} \rightarrow \emptyset / - \& s$$

*kwīṛt & s & pin & i* (4.3.1.2.2)  $\rightarrow$  *kwīṛ & s & pin & i*

*nenṯ & s & pin & i* (4.3 1.2.2)  $\rightarrow$  *nen & s & pin & i*

*aṛṯ & s & pin & i* (4 3.1.2 2)  $\rightarrow$  *aṛ & s & pin & i*

*nenṯ & s & pin & i* (4.3.1 2 2)  $\rightarrow$  *nen & s & pin & i*

*pūṣoḍṯ & s & pin & i* (4 3.1.2 2)  $\rightarrow$  *pūsoḍ & s & pin & i*

*parṯ & s & pin & i* (4.3.1 2.2)  $\rightarrow$  *par & s & pin & i*

*monc & s & pin & i* (4.3.1 2.2)  $\rightarrow$  *mon & s & pin & i*

*karc & s & pin & i* (4 3 1 2 2)  $\rightarrow$  *kar & s & pin & i*

2.42.  $s \longrightarrow z / d \ \& \text{---}$

<i>pod</i> & <i>s</i> & <i>pin</i> & <i>i</i>	(4 3 1 2 2)	$\longrightarrow$	<i>pod</i> & <i>z</i> & <i>pin</i> & <i>i</i>
<i>tod</i> & <i>s</i> & <i>pin</i> & <i>i</i>	(4 3 1 2 2)	$\longrightarrow$	<i>tod</i> & <i>z</i> & <i>pin</i> & <i>i</i>
<i>u'd</i> & <i>s</i> & <i>pin</i> & <i>i</i>	(4 3 1 2 2)	$\longrightarrow$	<i>u'd</i> & <i>z</i> & <i>pin</i> & <i>i</i>
<i>sö:d</i> & <i>s</i> & <i>pin</i> & <i>i</i>	(4 3.1 2 2)	$\longrightarrow$	<i>sö:d</i> & <i>z</i> & <i>pin</i> & <i>i</i>

2.43.  $s \longrightarrow \underset{\_}{s} / \underset{\_}{t} \ \& \text{---}$

<i>pī</i> <u>̣</u> & <i>s</i> & <i>pin</i> & <i>i</i>	(4 3 1 2 2)	$\longrightarrow$	<i>pī</i> <u>̣</u> & <u>̣</u> <i>s</i> & <i>pin</i> & <i>i</i>
<i>mu.ne</i> <u>̣</u> & <i>s</i> & <i>pin</i> & <i>i</i>	(4 3 1 2 2)	$\longrightarrow$	<i>mu.ne</i> <u>̣</u> & <u>̣</u> <i>s</i> & <i>pin</i> & <i>i</i>
<i>tü</i> <u>̣</u> & <i>s</i> & <i>pin</i> & <i>i</i>	(4.3 1 2 2)	$\longrightarrow$	<i>tü</i> <u>̣</u> & <u>̣</u> <i>s</i> & <i>pin</i> & <i>i</i>
<i>no:</i> <u>̣</u> & <i>s</i> & <i>pin</i> & <i>i</i>	(4 3.1 2 2)	$\longrightarrow$	<i>no:</i> <u>̣</u> & <u>̣</u> <i>s</i> & <i>pin</i> & <i>i</i>

2.44.  $s \longrightarrow \underset{\_}{z} / \underset{\_}{d} \ \& \text{---}$

<i>nī</i> <u>̣</u> & <i>s</i> & <i>pin</i> & <i>i</i>	(4 3 1 2 2)	$\longrightarrow$	<i>nī</i> <u>̣</u> & <u>̣</u> <i>s</i> & <i>pin</i> & <i>i</i>
<i>ka</i> <u>̣</u> & <i>s</i> & <i>pin</i> & <i>i</i>	(4 3 1 2 2)	$\longrightarrow$	<i>ka</i> <u>̣</u> & <u>̣</u> <i>s</i> & <i>pin</i> & <i>i</i>
<i>tī</i> <u>̣</u> & <i>s</i> & <i>pin</i> & <i>i</i>	(4.3.1 2 2)	$\longrightarrow$	<i>tī</i> <u>̣</u> & <u>̣</u> <i>s</i> & <i>pin</i> & <i>i</i>
<i>twī:d</i> & <i>s</i> & <i>pin</i> & <i>i</i>	(4 3 1 2 2)	$\longrightarrow$	<i>twī:d</i> & <u>̣</u> <i>s</i> & <i>pin</i> & <i>i</i>

2.45.

$s \longrightarrow \check{s} \left\{ \begin{array}{c} t \\ \check{c} \\ i \\ p \\ b \\ f \\ m \end{array} \right\} \ \& \text{---}$

*pī*t & *s* & *pin* & *i* (S 2 26 / 4 3 1.2.2)  $\longrightarrow$  *pī*t & *š* & *pin* & *i*

*e:mo:t & s & pin & i* (S.2.26 4.3.1.2.2)  $\rightarrow$  *e:mo:t & š & pin & i*

*pint & s & pin & i* (S.2.26 4.3.1.2.2)  $\rightarrow$  *pint & š & pin & i*

*ki.ř & s & pin & i* (S.2.26 4.3.1.2.2)  $\rightarrow$  *ki.č & š & pin & i*

*ko.č & s & pin & i* (S.2.26 4.3.1.2.2)  $\rightarrow$  *ko:č & š & pin & i*

*u:č & s & pin & i* (S.2.26 4.3.1.2.2)  $\rightarrow$  *u:č & š & pin & i*

*pi. & s & pin & i* (S.2.26 4.3.1.2.2)  $\rightarrow$  *pi. & š & pin & i*

*ašp & s & pin & i* (S.2.26 4.3.1.2.2)  $\rightarrow$  *ašp & š & pin & i*

*nob & s & pin & i* (S.2.26 4.3.1.2.2)  $\rightarrow$  *nob & š & pin & i*

*kuf & s & pin & i* (S.2.26 4.3.1.2.2)  $\rightarrow$  *kuf & š & pin & i*

*kum & s & pin & i* (S.2.26 4.3.1.2.2)  $\rightarrow$  *kum & š & pin & i*

246.  $s \rightarrow \check{z} / \left\{ \begin{array}{c} d \\ j \end{array} \right\} \& -$

*ked & s & pin & i* (S.2.26 4.3.1.2.2)  $\rightarrow$  *ked & ž & pin & i*

*ni d & s & pin & i* (S.2.26 4.3.1.2.2) → *ni:d & ž & pin & i*

*ud & s & pin & i* (S.2.26 4.3.1.2.2) → *ud & ž & pin & i*

*oĵ & s & pin & i* (S.2.26 4.3.1.2.2) → *oĵ & ž & pin & i*

*pu:ĵ & s & pin & i* (S.2.26 4.3.1.2.2) → *pu:ĵ & ž & pin & i*

2 47.  $s \rightarrow \text{\textcircled{s}}$  /  $\left\{ \begin{array}{c} t \\ k \\ g \\ x \end{array} \right\} \& \text{---}$

*ot & s & pin & i* [4.3.1.2.2] → *ot & \text{\textcircled{s}} & pin & i*

*poġ & s & pin & i* [4.3.1.2.2] → *poġ & \text{\textcircled{s}} & pin & i*

*a foġ & s & pin & i* [4.3.1.2.2] → *a foġ & \text{\textcircled{s}} & pin & i*

*wī·rīt & s & pin & i* [4.3.1.2.2] → *wī rīt & \text{\textcircled{s}} & pin & i*

*nwī:t & s & pin & i* (S.2.26 4.3.1.2.2) → *nwī:t & \text{\textcircled{s}} & pin & i*

*ni t & s & pin & i* (S.2.26 4.3.1.2.2) → *ni t & \text{\textcircled{s}} & pin & i*

*puk & s & pin & i* [4.3.1.2.2] → *puk & \text{\textcircled{s}} & pin & i*

*kark & s & pin & i* (S.2.26 4.3.1.2.2) → *kark & \text{\textcircled{s}} & pin & i*

*tīrk & s & pin & i* (S.2.26 4.3.1.2.2) → *tīrk & \text{\textcircled{s}} & pin & i*

*moṛk & s & pin & i* (S.2.26 4.3.1.2.2)  $\rightarrow$  *moṛk & ṣ & pin & i*

*omk & s & pin & i* (S.2.26 4.3.1.2.2)  $\rightarrow$  *omk & ṣ & pin & i*

*wa:g & s & pin & i* (S.2.26 4.3.1.2.2)  $\rightarrow$  *wa:g & ṣ & pin & i*

2.48.  $s \rightarrow z / d \& -$

*nīḍ & s & pin & i* [4.3.1.2.2]  $\rightarrow$  *nīḍ & z & pin & i*

*kwīḍ & s & pin & i* [4.3.1.2.2]  $\rightarrow$  *kwīḍ & z & pin & i*

*teṣkwīḍ & s & pin & i* [4.3.1.2.2]  $\rightarrow$  *teṣkwīḍ & z & pin & i*

*koḍ & s & pin & i* (S.2.40 4.3.1.2.2)  $\rightarrow$  *koḍ & z & pin & i*

2.49.

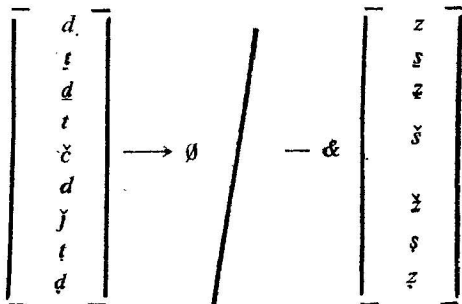

*poḍ & s & pin & i* [S.2.42]  $\rightarrow$  *poḍ & z & pin & i*

*toḍ & z & pin & i* [S.2.42]  $\rightarrow$  *toḍ & z & pin & i*

*u:ḍ & z & pin & i* [S.2.42]  $\rightarrow$  *u: & z & pin & i*

*sō:ḍ & z & pin & i* [S.2.42]  $\rightarrow$  *sō: & z & pin & i*

<i>pī</i> & <i>ḡ</i> & <i>pin</i> & <i>i</i>	(S.2.43)	—>	<i>pī</i> & <i>ḡ</i> & <i>pin</i> & <i>i</i>
<i>mu:ne</i> & <i>ḡ</i> & <i>pin</i> & <i>i</i>	(S.2.43)	—>	<i>mu:ne</i> & <i>ḡ</i> & <i>pin</i> & <i>i</i>
<i>tū</i> & <i>ḡ</i> & <i>pin</i> & <i>i</i>	(S.2.43)	—>	<i>tū</i> & <i>ḡ</i> & <i>pin</i> & <i>i</i>
<i>no:</i> & <i>ḡ</i> & <i>pin</i> & <i>i</i>	(S.2.43)	—>	<i>no:</i> & <i>ḡ</i> & <i>pin</i> & <i>i</i>
<i>nī</i> & <i>z̄</i> & <i>pin</i> & <i>i</i>	(S.2.44)	—>	<i>nī</i> & <i>z̄</i> & <i>pin</i> & <i>i</i>
<i>ka</i> & <i>z̄</i> & <i>pin</i> & <i>i</i>	(S.2.44)	—>	<i>ka</i> & <i>z̄</i> & <i>pin</i> & <i>i</i>
<i>ī</i> & <i>z̄</i> & <i>pin</i> & <i>i</i>	(S.2.44)	—>	<i>ī</i> & <i>z̄</i> & <i>pin</i> & <i>i</i>
<i>twī:</i> & <i>z̄</i> & <i>pin</i> & <i>i</i>	(S.2.44)	—>	<i>twī:</i> & <i>z̄</i> & <i>pin</i> & <i>i</i>
<i>pī</i> & <i>š</i> & <i>pin</i> & <i>i</i>	(S.2.45)	—>	<i>pī</i> & <i>š</i> & <i>pin</i> & <i>i</i>
<i>e:mo:</i> & <i>š</i> & <i>pin</i> & <i>i</i>	(S.2.45)	—>	<i>e:mo:</i> & <i>š</i> & <i>pin</i> & <i>i</i>
<i>pī</i> & <i>š</i> & <i>pin</i> & <i>i</i>	(S.2.45)	—>	<i>pīn</i> & <i>š</i> & <i>pin</i> & <i>i</i>
<i>ki:</i> & <i>š</i> & <i>pin</i> & <i>i</i>	(S.2.45)	—>	<i>ki:</i> & <i>š</i> & <i>pin</i> & <i>i</i>
<i>ko:</i> & <i>š</i> & <i>pin</i> & <i>i</i>	(S.2.45)	—>	<i>ko:</i> & <i>š</i> & <i>pin</i> & <i>i</i>
<i>u:</i> & <i>š</i> & <i>pin</i> & <i>i</i>	(S.2.45)	—>	<i>u:</i> & <i>š</i> & <i>pin</i> & <i>i</i>
<i>ke</i> & <i>ž</i> & <i>pin</i> & <i>i</i>	(S.2.46)	—>	<i>ke</i> & <i>ž</i> & <i>pin</i> & <i>i</i>
<i>ni:</i> & <i>ž</i> & <i>pin</i> & <i>i</i>	(S.2.46)	—>	<i>ni:</i> & <i>ž</i> & <i>pin</i> & <i>i</i>
<i>u</i> & <i>ž</i> & <i>pin</i> & <i>i</i>	(S.2.46)	—>	<i>u</i> & <i>ž</i> & <i>pin</i> & <i>i</i>
<i>o</i> & <i>ž</i> & <i>pin</i> & <i>i</i>	(S.2.46)	—>	<i>o</i> & <i>ž</i> & <i>pin</i> & <i>i</i>
<i>pu:</i> & <i>ž</i> & <i>pin</i> & <i>i</i>	(S.2.46)	—>	<i>pu:</i> & <i>ž</i> & <i>pin</i> & <i>i</i>
<i>o</i> & <i>š</i> & <i>pin</i> & <i>i</i>	(S.2.47)	—>	<i>o</i> & <i>š</i> & <i>pin</i> & <i>i</i>
<i>po</i> & <i>š</i> & <i>pin</i> & <i>i</i>	(S.2.47)	—>	<i>po</i> & <i>š</i> & <i>pin</i> & <i>i</i>
<i>a:fo</i> & <i>š</i> & <i>pin</i> & <i>i</i>	(S.2.47)	—>	<i>a:fo</i> & <i>š</i> & <i>pin</i> & <i>i</i>
<i>wī:rī</i> & <i>š</i> & <i>pin</i> & <i>i</i>	(S.2.47)	—>	<i>wī:rī</i> & <i>š</i> & <i>pin</i> & <i>i</i>

<i>nwī:t &amp; š &amp; pin &amp; i</i>	(S.2.47)	→	<i>nwī: &amp; š &amp; pin &amp;</i>
<i>ni:t &amp; š &amp; pin &amp; i</i>	(S.2.47)	→	<i>ni: &amp; š &amp; pin &amp; i</i>
<i>ni:ḍ &amp; z &amp; pin &amp; i</i>	(S.2.48)	→	<i>nī: &amp; z &amp; pin &amp; i</i>
<i>kwīḍ &amp; z &amp; pin &amp; i</i>	(S.2.48)	→	<i>kwī &amp; z &amp; pin &amp; i</i>
<i>teškwīḍ &amp; z &amp; pin &amp; i</i>	(S.2.48)	→	<i>teškwī &amp; z &amp; pin &amp; i</i>
<i>koḍ &amp; z &amp; pin &amp; i</i>	(S.2.48)	→	<i>ko &amp; z &amp; pin &amp; i</i>

2.50       $\left\{ \begin{array}{l} s \\ i \\ b \end{array} \right\} + t \longrightarrow \check{c}$

<i>pi:š &amp; t &amp; i</i>	(4.18.3.1)	→	<i>pi:č &amp; i</i>
<i>e:mo:š &amp; t &amp; i</i>	(4.18.3.1)	→	<i>e:mo:č &amp; i</i>
<i>püšodš &amp; t &amp; i</i>	(4.18.3.1)	→	<i>püšodč &amp; i</i>
<i>pars &amp; t &amp; i</i>	(4.18.3.1)	→	<i>parč &amp; i</i>

2.51.       $ak \longrightarrow a:k \quad / \left\{ \begin{array}{l} mu \\ w\bar{i}nbo \end{array} \right\} \& -$

<i>mu &amp; ak</i>	(3.6.3.1)	→	<i>mu &amp; a:k</i>
<i>wīnbo &amp; ak</i>	(3.6.9.2)	→	<i>wīnbo &amp; a:k</i>

2.52.       $\left\{ \begin{array}{l} u \\ o \end{array} \right\} \longrightarrow \emptyset \quad / - \& a:$

<i>mu &amp; a:k</i>	(S.2.51)	→	<i>ma:k</i>
<i>wīnbo &amp; a:k</i>	(S.2.51)	→	<i>wīnba:k</i>

2.53.  $o \longrightarrow \emptyset / \_ \& V$

*V* stands for vowels

*po:r & o & en & i* (4.5.1.1)  $\longrightarrow$  *po:r & en & i*

*po:r & o & ĩy & i* (4.5.1.1)  $\longrightarrow$  *po:r & ĩy & i*

*nĭl & o & im & i* (4.5.1.1)  $\longrightarrow$  *nĭl & im & i*

*nĭl & o & um & i* (4.5.1.1)  $\longrightarrow$  *nĭl & um & i*

*uŋ & o & en & i* (4.18.1.5)  $\longrightarrow$  *uŋ & en & i*

*pod & kĭs & o & en & i* (4.18.1.5)  $\longrightarrow$  *pod & kĭs & en & i*

*pod & kĭs & o & ĩy & i* (4.18.3.1)  $\longrightarrow$  *pod & kĭs & ĩy & i*

*pod & kĭs & o & um & i* (4.18.1.13)  $\longrightarrow$  *pod & kĭs & um & i*

2.54.  $\left[ \begin{array}{c} \overline{po:r} \\ \overline{to:r} \end{array} \right] \longrightarrow \left[ \begin{array}{c} \overline{po:} \\ \overline{to:} \end{array} \right] / \_ \& \#$

$\# po:r \# \longrightarrow \# po: \#$

$\# to:r \# \longrightarrow \# to: \#$

# 3

## Nouns

3.0. Nouns are those which do not take tense suffixes but do take or are capable of taking case suffixes.

### 3.1. *Gender-Number suffixes*

In Toda there is no gender distinction. Toda has completely lost the gender distinction and in this language *ae* means both 'that person' and 'that thing' and the corresponding plural *aea:m* means both 'those persons' and 'those things'. Toda has only number distinction in pronouns and personal distinction in the finite verbs. However we can recognize masculine and feminine gender in certain nouns in the morphological level.

3.1.1. *Masculine Singular*

$$\{ -n \}$$

$$\infty -n, \infty -o:\xi, \infty -f, \infty -\emptyset$$
3.1.1.1.  $\infty -n$  occurs after these stems

Ex. <i>konody-n</i>	'Canarese man'
<i>par-n</i>	'Pariah caste man'
<i>kumo:r-n</i>	'potter'
<i>wokil-n</i>	'Vakkaliga caste man'
<i>toixi-n</i>	'goldsmith'
<i>sakli-n</i>	'cobbler'
<i>orf-n</i>	'Brahmin' (one sect of Badaga)
<i>tulk-n</i>	'muslim man'
<i>osx-n</i>	'washer man'
<i>koraf-n</i>	'man of Korva caste'
<i>tocxi-n</i>	'carpenter'
<i>pal-n</i>	'Valaiyan'
<i>pori-n</i>	'Paniya tribe'
<i>kasf-n</i>	'Kasaba tribe'
<i>kocxo:r-n</i>	'brass worker'
<i>koixyo:r-n</i>	'clever person'
<i>axexo:r-n</i>	'enemy'
<i>kwalyxo:r-n</i>	'murderer'
<i>mo:dixa-n</i>	'man of low caste'
<i>monyxoy:r-n</i>	'Govt. appointed man'

<i>kwaltxo:r-n</i>		'person who does building work'
<i>pilyxo:r-n</i>		'sorcerer'
<i>kofd-n</i> (2.17)	—>	<i>kofdŋ</i> 'man of Gowda caste'
<i>wīd-n</i> (2.17)	—>	<i>wīdŋ</i> 'name of a caste'
<i>ko{n</i> (2.17)	—>	<i>ko{n</i> 'thief'
<i>no:s-n</i> (2.18)	—>	<i>no:sŋ</i> 'barber'
<i>pe:t-n</i> (2.17)	—>	<i>pe:tŋ</i> 'name of caste'
<i>pīt-n</i> (2.17)	—>	<i>pītŋ</i> 'foolish fellow'
<i>e:t-n</i> (2.17)	—>	<i>e:tŋ</i> 'shepherd'

3.1.1.2. ∞ -o:t̥ occurs after these stems

Ex. <i>kel-o:t̥</i>	'old man'
<i>wīŋ-o:t̥</i>	'dairy man'
<i>per-o:t̥</i>	'ordinary person'
<i>mo:r-o:t̥</i>	'man of <i>melga:s</i> clan'
<i>poy-o:t̥</i>	'male affinal relative'
<i>kamaso:r-o:t̥</i>	'legendary Todas'
<i>tōw-o:t̥</i>	'diviner'
<i>tu:ə-o:t̥</i>	'messenger'
<i>e:f-o:t̥</i>	'servant'
<i>mod-o:t̥</i>	'man of same village'

3.1.1.3 ∞ -f occurs after the stem

Ex. <i>kwī:-f</i>	'Kota tribe'
-------------------	--------------

3.1.1.4.  $\infty - \emptyset$  occurs after these stems

Ex. <i>kurub</i> - $\emptyset$	$\rightarrow$ <i>kurub</i>	'Kurumba tribe'
<i>erṭ</i> - $\emptyset$	$\rightarrow$ <i>erṭ</i>	'Irula tribe'
<i>ars</i> - $\emptyset$	$\rightarrow$ <i>ars</i>	'whiteman, European'
<i>sity</i> - $\emptyset$	$\rightarrow$ <i>sity</i>	'man of Chettiar caste'
<i>twī:ty</i> - $\emptyset$	$\rightarrow$ <i>twī:ty</i>	'scavanger'
<i>wīḍe:r</i> - $\emptyset$	$\rightarrow$ <i>wīḍe:r</i>	'man of Udaiyar caste'

3.1.2. *Feminine Singular*

$$\left\{ \begin{array}{l} -\check{c} \end{array} \right\}$$

$$\infty - \check{c} \quad \infty - o\check{c} \quad \infty - ty \quad \infty - xity \quad \infty - i$$
3.1.2.1.  $\infty - \check{c}$  occur after these stems

Ex. <i>kurub</i> - $\check{c}$	'Kurumba woman'
<i>erṭ</i> - $\check{c}$	'Irula woman'
<i>eṭ</i> - $\check{c}$	'woman of shepherd'
<i>poṇi</i> - $\check{c}$	'Paniya woman'
<i>wokīl</i> - $\check{c}$	'Vakkaliga woman'
<i>pe:t</i> - $\check{c}$	'woman of <i>pe:tṇ</i> '
<i>konody</i> - $\check{c}$	'Canarese woman'
<i>paṛ</i> - $\check{c}$	'Pariah woman'
<i>sity</i> - $\check{c}$	'woman of Chettiar caste'
<i>sakli</i> - $\check{c}$	'woman of cobbler'
<i>tulk</i> - $\check{c}$	'Muslim woman'
<i>wīḍ</i> - $\check{c}$	'woman of <i>wīḍṇ</i> caste'

3.1.2.2.  $\infty - o\check{c}$  occurs after this stem

Ex. <i>kel</i> - $o\check{c}$	'old woman'
-------------------------------	-------------

3.1.2.3.  $\infty$  -*xīty* occurs after this stem

Ex. *no:ṣ-xīty* 'barber woman'

3.1.2.4.  $\infty$  -*ty* occurs after these stems

Ex. *osx-ty* 'washer woman'  
*kwī:-ty* 'woman of Kota tribe'  
*kasf-ty* 'woman of Kasaba tribe'  
*wīrxī-ty* 'husband's brother's wife'  
*ō:rf-ty* 'Brahmin woman lower sect of  
 Badaga)  
*mad-ty* 'non-Toda woman'  
*ma:dixa-ty* 'woman of lower caste'

3.1.2.5.  $\infty$  -*i* occurs after the stem

Ex. *kiṛiṣtn-i* 'Christian woman'

3.1.3. *Non-neuter*

{ -*ry* }

3.1.3.1.  $\sim$  -*ry* occurs after the stem *o:-*

Ex. *o:-ry* 'who'

3.1.4. *Number suffixes*

In Toda, first, second and reflexive pronouns distinguish only number.

Ex. *o:n* 'I'  
*om* 'we (incl.)'  
*em* 'we (excl.)'

<i>nī:</i>	'you (sg.)'
<i>nīm</i>	'you (pl)'
<i>to:n</i>	'oneself'
<i>tam</i>	'themselves'

3.1.4.1. *Singular*

$$\{ -n \}$$

$$\infty -n, \infty -\theta, \infty -\emptyset$$
3.1.4.1.1.  $\infty -\theta$  occurs after the demonstrative base *a-*Ex. *a-\theta* 'he / she / it-that'3.1.4.1.2.  $\infty -\emptyset$  occurs after the second person stemEx. *ni:-\emptyset*  $\rightarrow$  *ni:* 'you (sg.)'3.1.4.1.3.  $\infty -n$  occurs elsewhereEx. *o:-n* 'I'*e-n-a:l*  $\rightarrow$  *ena:l* 'by me'*nī-n-a:l*  $\rightarrow$  *nīna:l* 'by you'*to:-n* 'oneself'3.1.4.2. *Plural*

$$\{ -m \}$$

$$\infty -m, \infty -a:m$$
3.1.4.2.1.  $\infty -m$  occurs after the first person (both inclusive and exclusive) and second person and reflexive stems.

Ex. <i>o-m</i>	'we (incl.)'
<i>e-m</i>	'we (excl.)'
<i>nī-m</i>	'you (pl.)'
<i>ta-m</i>	'themselves.'

### 3.1.4.2.2. Common plural

∞ - *a:m* occurs elsewhere

Ex. <i>aθ-a:m</i>	'they / those'
<i>o:ɕ-a:m</i>	'Toda men'
<i>tojmox-a:m</i>	'Toda women'
<i>mox-a:m</i>	'boys'
<i>ku:x-a:m</i>	'girls'
<i>pō:ɾ-a:m</i>	'Tamilians'
<i>ma:f-a:m</i>	'Badagas'
<i>kwī:f-a:m</i>	'Kotas'
<i>püşy-a:m</i>	'tigers'
<i>pe:ɕ-a:m</i>	'fingers'
<i>īr-a:m</i>	'buffaloes'
<i>me:ŋ-a:m</i>	'tress'
<i>pōɕk a:m</i>	'lamps'

## 3.2. Cases

### 3.2.1 Inflexional increments

{ -t- }

∞ -n-, ∞ -t-

3.2.1.1.  $\infty$ -*n*- occurs after third person pronoun and after nouns and before instrumental case suffix *-a:l*.

- Ex. *aə-n-a:l* 'by that-it'  
*iə-n-a:l* 'by this-it'  
*ak ku:x-n-a:l enk upum kašm ʔyi*  
 'I have problems because of her'

3.2.1.2.  $\infty$ -*t*- occurs after the stems ending in *-m* and before dative and locative case suffixes.

- Ex. *sonm-t-k* (2.7)  $\rightarrow$  *Sontk* 'to people'  
*ku:dm-t-k* (2.7)  $\rightarrow$  *ku:dk* 'to the meeting'  
*no:ym-t-k* (2.7)  $\rightarrow$  *no:yt* 'to the assembly'  
*kīnm-t-k* (2.7)  $\rightarrow$  *kīntk* 'to cup'  
*pojo:rm-t-k* (2.7)  $\rightarrow$  *pojo:rtk* 'to Ootacamund'  
*me:ṅ-t-k*  $\rightarrow$  *me:ṅtk* 'to the tree'  
*me:ṅ-t-ḡ*  $\rightarrow$  *me:ṅ-tḡ* 'in the tree'

### 3.2.2. Case suffixes

Cases are ten in number

#### 3.2.2.1. Accusative

{ -*n* }

~ -*n*

~ -*n* occurs after all stems

- Ex. *wīṛfed-n* 'younger brother (obj.)'  
*o:ṭ-n* (2.17)  $\rightarrow$  *o:ṭn* 'Toda man (obj.)'

<i>ku:x-n pa:t</i>	'catch the girl'
<i>koɾ-n pe:t</i>	'drive the calf'
<i>o:n ɪne:ɾ nīm-n koʒpini</i>	'I saw you yesterday'
<i>o:n ɪr-n pi:škpini</i>	'I kill buffalo'
<i>aə en wīɾfed-n pīsti</i>	'He beats my younger brother'

## 3.2.2.2. Instrumental

{ -a:l }

∞ -a:l, -id, ∞ -a:ɾ, ∞ -iɪ

∞ -a:ɾ occurs after noun stems 'belonging to human body parts.

Ex. <i>koŋ-a:ɾ</i>	'with eye'
<i>kɪfy-a:ɾ</i>	'with ear'
<i>koy-a:ɾ</i>	'with hand'
<i>po:y-a:ɾ</i>	'with mouth'
<i>o:n koŋ-a:ɾ koʒpini</i>	'I saw with eye'
<i>o:n kɪfy-a:ɾ ke:tkin</i>	'I hear with ear'
<i>o:n po:y-a:ɾ af:oɾpini</i>	'I talk with mouth'
<i>o:n koy-a:ɾ kelc kīspini</i>	'I did work with hand'

∞ -iɪ occurs after noun stems belonging to inanimate class (other than the above).

Ex. <i>mošt-iɪ</i>	'with an axe'
<i>mod-iɪ</i>	'with chuning rod'
<i>tu:ɾy-iɪ</i>	'with knife'

*o:n mošt-it me:n kwartpini* 'I cut the tree with axe'

*o:n mod-it po:g karəpini* 'I churn milk with  
churning rod'

*o:n iu:ry-it peɾx kwartpini* 'I cut the fuel with knife'

∞-a:l occurs elsewhere and it is in free variation with -id.

Ex. *om-a:l*

*om-id* 'by us'

*nīn-a:l*

*nīn-id* 'by you'

*en-a:l*

*en-id* 'by me'

*aə-n-a:l*

'by that'

*iə-n-al*

'by this'

*ak ku:x-n-a:l enk upum kaştm İyi*

*ak ku:x-id enk upum kaştm İyi*

'I have troubles because of that girl'

### 3.2.2.3. Sociative

{ -*pody* }

~ -*pody*, -*wīɾ*

~ -*pody* occurs after all stems and it is in free variation with -*wīɾ*.

Ex. *en-pody*

'with me'

*en-wīɾ*

*nīn-pody*

'with you'

*nīn-wīɾ*

<i>kurub-pody</i>	'with Kurumba tribe'
<i>kurub-wīṛ</i>	
<i>nīn-pody o:n paṣkin</i>	'I come with you'
<i>nīn-wīṛ o:n paṣkin</i>	
<i>piṣyxe:n-wīṛ o:n makolk podpini</i>	'I will come with Pelikan to-morrow'
<i>īr-pody kor padī</i>	'calf comes with buffalo'
<i>pō:ṛ-wīṛ fō:ṛ</i>	'Tamilians with Tamilians'
<i>ars-wīṛ ars</i>	'Europeans with Europeans'
<i>tojmox-wīṛ a:foṛoṭi</i>	'Do not talk with Toda woman'
<i>nīn-pody tīnkin</i>	'I eat with you'

## 3.2.2.4. Dative

{ -k }  
~ -k

~-k occurs after all stems

Ex. <i>en-k</i>	'to me'
<i>nīn-k</i>	'to you'
<i>a:g-k</i>	'to house'
<i>poṣy-k</i>	'to dairy'
<i>ko:ifoy-k</i>	'to wife'
<i>moḍ-k</i>	'to Toda mund'
<i>sonm-t-k</i> (2.7) →	<i>sontk</i> 'to people'
<i>no:ym-t-k</i> (2.7) →	<i>no:ytk</i> 'to the assembly'

*kīnm-t-k* (2.7) —> *kīnk* 'to cup'

*kō:r-k* (2.8) —> *kō:tk* 'to lake'

*aə ɪne:r to:ro: rmod-k pi:či*

'He went to Taranad mund yesterday'

*nīn-k in pē:k?* 'What do you want?'

*ni: etfīn u:r-k pi:ti* 'When did you go home'

*en-k mu:d ku:x wīḍy* 'I have three daughters'

Dative is also used in the locative and purposive sense in Toda language.<sup>1</sup>

*ekaṛfoṭk* 'in the evening'

*o:n pu:txuḷy poṭyk poṣpini* 'I kept cloak in the box'

*en afk po:ḡ e:s pozpini*

'I have brought milk for my mother'

### 3.2.2.5. Ablative

{ -ḡn }

~ -ḡn

~ -ḡn occurs after all the stems

1. Dative is used in locative sense in Sangam Tamil literature also.

*Kiḷaiyari na:ṇar kiḷaṅku maṇar ki:nṛa*

*muḷaiyo: ranna muḷḷeyiṛrut tuvarva:y* (Akam, 212)

In Malayalam language also dative is used in the locative, genitive and purposive sense.

Gundert, A; *Malayala Bhasavyakaranam* p. 153-157, 1868

Ex. <i>aṭ-ṣn</i>		'from there'
<i>iṭ-ṣn</i>		'from here'
<i>eṭ-ṣn?</i>		'from where?'
<i>moḍ-ṣn</i>		'from the mund'
<i>kwī:ko:l-ṣn</i>		'from Kota village'
<i>pojo:rm-t-ṣn</i> (2.7)	—>	<i>pojo:rt-ṣn</i> 'from Ootacamund'
<i>i:škity-ṣn</i> (2.14)	—>	<i>i:škity-ṣn</i> 'from Ka:ṣ mund'
<i>koce:ry-ṣn</i> (2.14)	—>	<i>koce:ry-ṣn</i> 'from court'
<i>uṭ-ṣn</i> (2.15,17)	—>	<i>uṭ-ṣn</i> 'from inside'
<i>ko:ṛōw-ṣn</i> (2.15,17)	—>	<i>ko:ṛōw-ṣn</i> 'from Nirṃ mund'
<i>o:n melga:ṣ moḍ-ṣn pozpini</i>		'I came from Garden mund'
<i>o:n pojo:rt-ṣn pozpini</i>		'I came from Ootacamund'

## 3.2 2.6. Genitive

{ -n }

~ -n

Ex. <i>nīn-n a:ṣ</i> (2.18)	—>	<i>nīn a:ṣ</i> 'your house'
<i>en-n a:ṣ</i> (2.18)	—>	<i>en a:ṣ</i> 'my house'
<i>nīn-n ṭr</i> (2.18)	—>	<i>nīn ṭr</i> 'your buffalo'
<i>en o:ṭ-n</i> (2.17)	—>	<i>en o:ṭn</i> 'my husband's'
<i>en wīṛfed-n o:ṭ</i>		'my younger sister's husband'
<i>en ok-n o:ṭ</i>		'my elder sister's husband'

<i>ku:x-n o:ɛ</i>	'daughter's husband'
<i>ku:x-n-mox</i>	'daughter's son'
<i>en o:ɛŋ dan ok-n o:ɛ</i>	'my husband's elder sister's husband'

3.2.2.7. *Locative*

{ -s }

∞ -s ∞ -kīdɟ

∞ *kīdɟ* occurs after animate nouns

Ex. <i>en-kīdɟ</i>	'with me'
<i>an-kīdɟ</i>	'with him'
<i>ku:x-kīdɟ</i>	'with girl'
<i>an-kīdɟ poŋm o:ɾəy</i>	'He has no money'
<i>an-kīdɟ upum ɪr wīdɟ</i>	'He has more buffaloes'
<i>ak ku:x-kīdɟ upum pu:txuɛy wīdɟ</i>	'That girl has more cloaks'
<i>kor-kīdɟ a:py upum wīdɟ</i>	'There is much cowdung near the calf'

∞ -s occurs elsewhere

Ex. <i>me:ŋ-t-s</i> → <i>me:ŋts</i>	'in the tree'
<i>Kaʃtal-s</i>	'in the darkness'
<i>ekarɟot-s</i>	'in the evening'
<i>em u:ɾ-s neln upum wīdɟ</i>	'we have more lands in our village'

<i>mu:d poŕy-ŝ</i>	(2.14) —>	<i>mu:d poŕyš</i>	‘in three dairies’
<i>kulo:y-ŝ</i>	(2.14) —>	<i>kulo:yš</i>	‘in the tap’
<i>ađy-ŝ</i>	(2.14) —>	<i>ađyš</i>	‘in the pot’
<i>po:y-ŝ</i>	(2.14) —>	<i>po:yš</i>	‘in the mouth’
<i>pax uŕ-ŝ</i>	(2.15) —>	<i>pax uŕš</i>	‘in the midst of cloud’
<i>mu:d twī:ŝ</i>	(2.16) —	<i>mu:d twī:š</i>	‘in three pens’

## 3.2 2.8. Purposive

{ -go:y }

~ -go:y

~ -go:y occurs after all stems

Ex. <i>en-go:y</i>	‘for my sake’
<i>nīn-go:y</i>	‘for your sake’
<i>an-go:y</i>	‘for his / her sake’
<i>en-go:y i kelc kīy</i>	‘Do this work for my sake’
<i>nīn-go:y i:nk pozpīni</i>	‘I came here for your sake’
<i>ka:wıwītŋ em-go:y i kelc kīstīř</i>	‘Kawkuttan works for us’
<i>nīn-go:y o:n am mođk pi:špīni</i>	‘I went to that mund for your sake’
<i>an-go:y i kelc kīspīni</i>	‘I did this work for his sake’

3.2.2.9. *Vocative*

$$\{ -a: \}$$

$$\infty -a: \quad \infty -ya: \quad \infty -\emptyset$$

$\infty -a:$  occurs after these stems.

Ex. *oŋ* → *oŋ-a:* 'oh my elder brother'

*piaf* → *piaf-a:* 'oh my grand mother'

*eyi:-a* (2.19) → *eya:* 'oh my father'

*okn-a* (2.19) → *oka:* 'oh my elder sister'

$\infty -ya:$  occurs after these stems

Ex. *mox* *mox-ya:* 'oh son'

*ku:x* *ku:x-ya:* 'oh daughter'

*o:ɕ* *o:ɕ-ya:* 'oh husband'

*tojmax* *tojmax-ya:* 'oh wife'

$\infty -\emptyset$  occurs elsewhere

Ex. *mutna:ɕ-∅* *mutna:ɕ* 'oh Mutnas'

*to:j-∅* *to:j* 'oh Taj'

*ka:wxwɪŋ-∅* *ka:wxwɪŋ* 'oh Kawkuttan'

*artofɪn-∅* *artofɪn* 'oh Artapin'

*tōwbnɪɕ-∅* *tōwbnɪɕ* 'oh tebnis'

*nesfiɕy-∅* *nesfiɕy* 'oh Nespily'

3.3. *Stem classification*

All those stems which can take gender-number suffixes belong to this class and they are classified on the basis of the

masculine suffix they take. Each main class is further subdivided on the basis of feminine suffixes they take.

3.3.1. Those stems which take masculine suffix *-n* belong to this class.

Ex. <i>konod̥y-n</i>	'Canarese man'
<i>paṛ-n</i>	'man of Pariah caste'
<i>wok̥l̥l-n</i>	'man of Vakkaliga'
<i>tulk-n</i>	'Muslim man'
<i>toṭx̥l̥-n</i>	'Goldsmith'
<i>osx-n</i>	'Washerman'
<i>kasf-n</i>	'Kasaba tribe'
<i>no:ʃ-n</i> (2.17) → <i>no:ʃn</i>	'Barber'

3.3.1.1. Those stems which take *-č* as feminine suffix.

Ex. <i>konod̥y-č</i>	'Canarese woman'
<i>paṛ-č</i>	'woman of Pariah caste'
<i>wok̥l̥l-č</i>	'woman of Vakkaliga caste'
<i>tulk-č</i>	'Muslim woman'
<i>poṇi-č</i>	'Paniya tribe'
<i>kof̥d-č</i>	'woman of Gowda caste'
<i>wīd̥-č</i>	'woman of <i>wīd̥n</i> caste'
<i>pe:t-č</i>	'woman of <i>pe:t̥n</i> '
<i>eṭ-č</i>	'shepherd woman'

3.3.1.2. Those which take *-ty* as feminine suffix.

Ex. <i>toṭx̥l̥-ty</i>	'woman of Goldsmith'
<i>o:rf-ty</i>	'Brahmin woman (one sect of Badaga)'

<i>osx-ty</i>	‘Washerwoman’
<i>mo:dixa-ty</i>	‘woman of <i>mo:dixan</i> ’
<i>kasf-ty</i>	‘woman of Kasaba tribe’

3.3.1.3. Those which take *-xīty* as feminine suffix.

Ex. <i>no:ṣ-xīty</i>	‘barber woman’
----------------------	----------------

3.3.2. Those stems which take *-o:ṣ* as masculine suffix belong to this class.

Ex. <i>kel-o:ṣ</i>	‘old man’
--------------------	-----------

3.3.2.1. Those which take *-oč* as feminine suffix.

Ex. <i>kel-oč</i>	‘old woman’
-------------------	-------------

3.3.3. Those which take *-f* as masculine suffix belong to this class

Ex. <i>kwī:-f</i>	‘Kota man’
-------------------	------------

3.3.3.1. Those which take *-ty* as feminine suffix

Ex. <i>kwī:-ty</i>	‘Kota woman’
--------------------	--------------

3.3.4. Those which take *-∅* as masculine suffix belong to this class.

Ex. <i>kurub-∅</i> → <i>kurub</i>	‘Kurumba tribe’
<i>erṣ-∅</i> → <i>erṣ</i>	‘Irula tribe’
<i>sity-∅</i> → <i>sity</i>	‘Chettiar’
<i>twī:ty-∅</i> → <i>twī:ty</i>	‘scavenger’
<i>wīḍe:r-∅</i> → <i>wīḍe:r</i>	‘man of Udaiyar caste’

## 3.3.4.1. Those which take -č̣ as feminine suffix

Ex. <i>kurub-č̣</i>	‘woman of Kurumba tribe’
<i>erč̣-č̣</i>	‘woman of Irula tribe’
<i>sity-č̣</i>	‘Chettiar woman’
<i>twī:ty-č̣</i>	‘scavenger woman’
<i>wīde:r-č̣</i>	‘woman of Udaiyar caste’

## 3.4. Inherent noun

The inherent nouns in Toda can be classified into two main classes, animate and inanimate. This classification is necessitated because certain nouns take *-kīḍʂ* as the locative case sign and certain others do not. Those which take *-kīḍʂ* are classified here as animate and the rest inanimate.

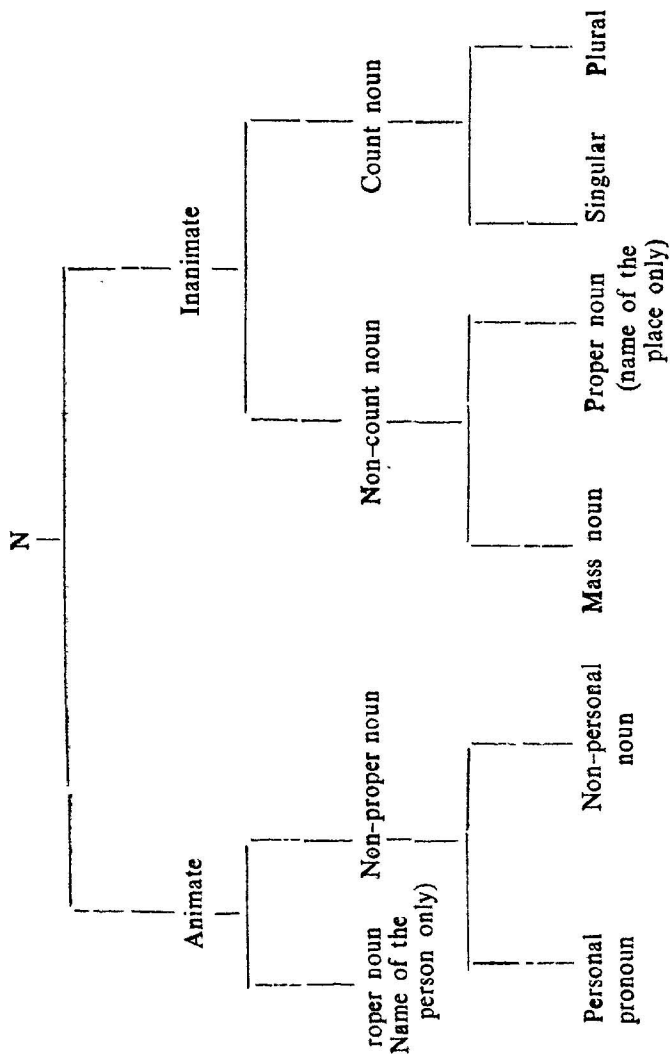

3.4.1. *Animate nouns*

Animate nouns are of two types. They are 1) Proper nouns and 2) Non-proper nouns. Non-proper nouns are further classified into personal nouns and non-personal nouns.

3.4.1.1. *Proper nouns*

Proper nouns are those which denote the names of person and they do not take plural suffix.

Ex. <i>tōwbnīš</i>	<i>pi:ldynīš</i>
<i>artofin</i>	<i>tūčcwī:nīš</i>
<i>erci:øy</i>	<i>ercigyfu:f</i>
<i>īrkwīrfīn</i>	<i>kōbu:fičy</i>
<i>kořofxwīčn</i>	<i>mašno:fičy</i>
<i>kwīčnaš</i>	<i>nešfičy</i>
<i>mu:nbo:wxwīčn</i>	<i>pīnswīle:my</i>
<i>nō:řo:ngwī:ř</i>	

3.4.1.2. *Non-proper nouns*

As already mentioned non-proper nouns are classified into 1) personal pronouns 2) non-personal nouns.

3.4.1.2.1. *Personal pronouns*

Ex. <i>o:n</i>	'I'
<i>om</i>	'we (incl.)'
<i>em</i>	'we (excl.)'
<i>ni:</i>	'you (sg.)'

<i>nīm</i>	'you (pl.)'
<i>aə</i>	'he / she / it'
<i>aəa:m</i>	'they / those'

3.4.1.2.2. Non-personal nouns are those which can take attributes.

Ex. <i>tojmoχ</i>	'Toda woman'
<i>moχ</i>	'boy'
<i>ku:x</i>	'girl'
<i>kurub</i>	'Kurumba tribe'
<i>ma:f</i>	'Badaga man'
<i>ars</i>	'king'
<i>erɕ</i>	'Irula'
<i>kopaɾ</i>	'butterfly'
<i>kō:g</i>	'barking deer'
<i>ku:ly</i>	'stud bull'
<i>kwaɽy</i>	'cat'
<i>ir</i>	'buffalo'
<i>paŋy</i>	'lizard'
<i>ka:k</i>	'crow'
<i>katy</i>	'ass'
<i>püŋy</i>	'tiger'
<i>koɾ</i>	'buffalo calf'

### 3.4 2. Inanimate nouns

Inanimate nouns can be classified into 1. non-count nouns and 2. count nouns. Non-count nouns are further classified into 1. mass noun and 2. proper noun.

Count noun takes or is capable of taking the common plural marker *-a:m* whereas proper noun (name of a place) and mass noun do not.

3.4.2.1. Proper nouns are those which denote the name of the place and do not take plural suffix.

Ex. <i>moysu:r</i>	'Mysore'
<i>kwa:ymütu:r</i>	'Coimbatore'
<i>mī:tpa:w</i>	'Mettupalayam'
<i>ku:lu:r</i>	'Gudalur'
<i>kulpe:txō:ɽ</i>	'Gundulpet'
<i>nojīrxuɽy</i>	'Nanjangod'
<i>ka:ɽmuɽ</i>	'Karamadai'
<i>kalikwa:ɽ</i>	'Calicut'
<i>sotymogolm</i>	'Sathiamangalam'
<i>no:xu:r</i>	'Nagore'
<i>maəra:č</i>	'Madras'

3.4.2.2. Mass nouns are those which also cannot take plural suffix.

Ex. <i>nīy</i>	'ghee'
<i>ni:r</i>	'water'
<i>po:š</i>	'milk'
<i>eŋo:y</i>	'oil'
<i>ašky</i>	'rice'

3.4.2.3. Inanimate count nouns are those which are capable of taking common plural marker *-a:m*.

Ex. <i>me:ŋ</i>	<i>me:ŋ-a:m</i>	'trees'
-----------------	-----------------	---------

<i>kaṣ</i>	<i>kaṣ-a:m</i>	'stones'
<i>kīḍf</i>	<i>kīḍf-a:m</i>	'shrubs'
<i>puxury</i>	<i>puxury-a:m</i>	'Toda flutes'
<i>pu:txuḷy</i>	<i>pu:txuḷy-a:m</i>	'cloaks'
<i>uly</i>	<i>uly-a:m</i>	'branding irons'
<i>toṛy</i>	<i>toṛy-a:m</i>	'poles used at funeral'

### 3.5. Personal pronouns

There are only two personal pronouns, first and second persons and they have number distinction viz. singular and plural. The third person is expressed by the demonstrative pronouns. In third person unlike Tamil etc. there is no gender distinction but only singular and plural number. The first person plural has two forms, an exclusive and inclusive.

#### 3.5.1. First person

{ o:- }

∞ o:- ∞ e-

3.5.1.1. ∞ e- occurs before singular suffix *-n* followed by either case suffixes or nouns.

Ex. <i>e-n-a:l</i>	'by me'
<i>e-n-k</i>	'to me'
<i>e-n-poḍy</i>	'with me'
<i>e-n-go:y</i>	'for my sake'
<i>e-n-kīḍṣ</i>	'with me'
<i>e-n-a:g</i>	'my house'

3.5.1.2.  $\infty o-$  occurs before singular suffix  $-n$

Ex.  $o:-n$  *podpini* 'I come'

$o:-n$  *pi:pini* 'I go'

3.5.1.3. *First person inclusive*

{  $o-$  }

$\infty o-$

3.5.1.3.1  $\infty o-$  occurs before plural suffix  $-m$

Ex.  $o-m-k$  'to us'

$o-m-a:l$  'by us'

$o-m-go:y$  'for oursake'

$o-m$  *podpimi* 'we come (incl.)'

3.5.1.4. *First person exclusive*

{  $e-$  }

$\infty e-$

3.5.1.4.1.  $\infty e-$  occurs before plural suffix  $-m$

Ex.  $e-m-n$  us (object.)

$e-m-a:l$  'by us'

$e-m-k$  'to us'

$e-m$ -*pody* 'with us'

$e-m$  *podpumi* 'we come (excl.)'

3.5.2. *Second person*

$$\{ ni: \}$$

$$\infty ni:, \infty n\bar{i}-$$

3.5.2.1.  $\infty n\bar{i}-$  occurs before singular and plural suffixes  $-n$  and  $m$  followed by either case suffixes or nouns.

Ex. $n\bar{i}-n-k$	'to you'
$n\bar{i}-n-a:l$	'by you'
$n\bar{i}-n-pody$	'with you'
$n\bar{i}-n a:g$	'your house'
$n\bar{i}-m-n$	'you (obj.)'
$n\bar{i}-m-a:l$	'by you'
$n\bar{i}-m-k$	'to you'
$n\bar{i}-m kelc k\bar{i}st\bar{s}i$	'you do work'

3.5.2.2.  $\infty ni:$  occurs before  $-\emptyset$

Ex. $ni:-\emptyset \rightarrow ni:$	'you (Sg.)'
$ni: tw\bar{i}:r t\bar{i}d\bar{p}i$	'you eat food'
$ni: po:g u\bar{d}p\bar{i}$	'you drink milk'

3.5.3. *Demonstrative pronoun*3.5.3.1. *Distant Demonstrative base*

$$\{ a- \}$$

$$\sim a-$$

3.5.3.1.1.  $\sim a-$ 

Ex. $a-\emptyset$	'that-he / she / it'
$a-\emptyset a:m$	'that-they / those'

3.5.3.2. *Proximate Demonstrative base*

{  $i-$  }

$\sim i-$

3.5.3.2.1.  $\sim i-$ 

Ex. $i-\emptyset$	'this-he / she / it'
$i-\emptyset a:m$	'this-they / those'

3.5.4. *Interrogative pronoun*

{  $o:-$  }

$\infty o:- \quad \infty e:-$

3.5.4.1.  $\infty o:-$  occurs before non-neuter suffix  $-ry$ 

Ex. $o:ry$	'who'
------------	-------

3.5.4.2.  $\infty e:-$  occurs before genderless suffix  $-\emptyset$ 

Ex. $e:-\emptyset$	'which'
--------------------	---------

3.5.5. *Universal pronoun*

Universal pronoun consists of three elements, viz interrogative base, genderless suffix and non-neuter suffix and universal clitic  $-um$ .

Inter. base + { Non-neuter suffix  
Genderless suffix } +  $um$

- Ex. *o:-ry-um* → *o:ryum* 'any body'  
*e:-ə-um* → *e:əum* 'any thing'

### 3.5.6. Indefinite pronoun

Indefinite pronoun consists of three elements viz interrogative base, non-neuter, non-human suffix and indefinite clitic *-isky*

Inter. base + { Non-neuter suffix  
Non-human suffix } + *isky*

- Ex. *o:r-isky* → *o:risky* 'somebody'  
*i-n-isky* → *inisky* 'something'

### 3.5.7. Reflexive

{ *to:-* }

∞ *to:* ∞ *ta-*

3.5.7.1. ∞ *ta-* occurs before singular suffix *-n* and plural suffix *-m* followed by case suffixes.

- Ex. *ta-n-k* 'to oneself'  
*ta-n-a:l* 'by oneself'  
*ta-n-go:y* 'for ownsake'  
*ta-m-k* 'to ourselves'  
*ta-m-a:l* 'by ourselves'  
*ta-m-go:y* 'for oursake'

3.5.7.2. ∞ *to:* occurs elsewhere

- Ex. *to:-n* 'oneself'

## 3.6. Numerals

3.6.1. *one*

$$\left\{ \text{wīḍ} \right\}$$
 $\infty$  *o-*,  $\sim$ -*wī:r-*,  $\infty$  *muda:l*,  $\infty$  -*wīḍ*

3.6.1.1.  $\infty$  *o-* occurs before *nu:r* 'hundred' *so:fer* 'thousand' and *kwa:w* 'ačok measure'.

Ex. <i>o nu:r</i>	'one hundred'
<i>o so:fer</i>	'one thousand'
<i>o kwa:w</i>	'eleven ačok measure'

3.6.1.2.  $\sim$ -*wī:r* occurs before *ak* 'ačok measure' and *o:r* 'year'.

Ex. <i>wī:r ak</i>	'one ačok measure'
<i>wī:r o:r</i>	'one year'

3.6.1.3.  $\infty$  *muda:l-* occurs before ordinal and adverbial suffix *-tīrk*.

Ex. <i>muda:l- a:fīθ</i>	'first'
<i>muda:l- tīrk</i>	'once'

3.6.1.4.  $\infty$  *wīḍ* occurs elsewhere

Ex. <i>wīḍ</i>	'one'
<i>pon wīḍ</i>	'eleven'
<i>wīḍ o:ṭ</i>	'one Toda man'
<i>wīḍ poṇm</i>	'4 Annas (old coin)'

<i>wīḍ roʃn</i>	'one king'
<i>wīḍ se:r</i>	'one seer measure'
<i>wīḍ ko:s</i>	'one rupee'
<i>wīḍ pi:čm</i>	'one <i>vi:če</i> measure'
<i>wīḍ moŋf</i>	'one <i>maŋaŋgu</i> measure'
<i>wīḍ moŋy</i>	'1 o' clock'

## 3.6.2. Two

{ e:d }

∞ ī-, ~ī:r-, ∞ e:d-

3.6.2.1. ∞ ī- occurs before *poə* 'ten' *nu:r* 'hundred' and *kwa:w* 'measure'

Ex. *ī poə* (2.5) → *ī foə* 'twenty'

*ī nu:r* 'two hundred'

*ī kwa:w* 'twenty two *ačok* measure'

3.6.2.2. ~ī:r- occurs before *ak* '*ačok* measure' and *o:r* 'year'

Ex. *ī:r ak* 'two *ačok* measure'

*ī:r o:r* 'two years'

3.6.2.3. ∞ e:d- occurs elsewhere

Ex. *e:d* 'two'

*pon e:d* 'twelve'

*e:d so:fer* 'two thousand'

*e:d moŋy* '2 o' clock'

<i>e:d poŋm</i>	'8 Annas (old coin)'
<i>e:d kwa:w</i>	'two <i>kwa:x</i> measure'
<i>e:d silyx</i>	'two big measure'
<i>e:d e:d</i>	'two each'

3.6.3. *Three*

{ *mu:d* }

∞ *mu-*, ∞ *mu:d-*

3.6.3.1. ∞ *mu-* occurs before *poθ* 'ten', *nu:ɾ* 'hundred', *kwa:w* 'measure' and *ak* 'ačok measure'

Ex. <i>mu poθ</i>	'thirty'
<i>mu nu:ɾ</i>	'three hundred'
<i>mu kwa:w</i>	'three <i>kwa:x</i> measure'
<i>mu-ak</i> (2.51, 52) → <i>ma:k</i>	'three ačok measure'

3.6.3.2. ∞ *mu:d* occurs elsewhere

Ex. <i>mu:d</i>	'three'
<i>poŋ mu:d</i>	'thirteen'
<i>mu:d o:t</i>	'three persons'
<i>mu:d koɾ</i>	'three calves'
<i>mu:d a:s</i>	'three houses'
<i>mu:d poŋm</i>	'12 Annas (old coin)'
<i>mu:d silyx</i>	'three big measure'
<i>mu:d mu:d</i>	'three each'

3.6.4. *Four*

$$\{ \text{no:ng} \}$$

$$\infty \text{ nal-} \quad \infty \text{ no:} \quad \infty \text{ a:ng} \quad \infty \text{ no:ng-}$$
3.6.4.1.  $\infty \text{ nal-}$  occurs before *poø* 'ten'Ex. *nalpoø* 'forty'3.6.4.2.  $\infty \text{ no:-}$  occurs before *nu:r* 'hundred' and *kwa:w* 'measure'Ex. *no: nu:r* 'four hundred'  
*no: kwa:w* 'four *kwa:x* measure'3.6.4.3.  $\infty \text{ a:ng-}$  occurs after *p* denoting 'ten'Ex. *p-a:ng* 'fourteen'  
*p-a:ng ak* '14 *ačok* measure'3.6.4.4.  $\infty \text{ no:ng-}$  occurs elsewhereEx. *no:ng* 'four'  
*no:ng moŋy* '4 o' clock'  
*no:ng o:č* 'four Toda men'  
*no:ng so:fer* 'four thousand'  
*no:ng ko:l* '4½'  
*no:ng silyx* 'four big measure'  
*no:ng nong* 'four each'

3.6.5. *Five*

{ üj }

∞ e-, ∞ ü:j-, ∞ oy-, ∞ üj-

3.6.5.1. ∞ e- occurs before *boø* 'ten' and *nu:ɾ* 'hundred' and it is in free variation with *oy* before *nu:ɾ*<sup>1</sup>

Ex. <i>eboø</i>	'fifty'
<i>enu:ɾ</i>	'five hundred'
<i>oynu:ɾ</i>	'five hundred' ( <i>Tõwfiɽy</i> moiety)

3.6.5.2. ∞ u:j occurs after *p* denoting 'ten'

Ex. <i>p-u:j</i>	'fifteen'
------------------	-----------

3.6.5.3. ∞ oy- occurs before *ak* and *kwa:w*

Ex. <i>oy ak</i>	'five <i>učok</i> measure'
<i>oy kwa:w</i>	'five <i>kwa:x</i> measure'

3.6.5.4. ∞ üj occurs elsewhere.

Ex. <i>üj</i>	'five'
<i>üj moŋy</i>	'five o' clock'
<i>üj o:ɽ</i>	'five Toda men'
<i>üj tojmax</i>	'five Toda women'
<i>üj poŋm</i>	'five (four annas) coin'
<i>üj so:fer</i>	'five thousand'

1 This form occurs in *Tõwfiɽy* moiety speech.

<i>üj silyx</i>	'five big measure'
<i>üj üj</i>	'five each'

3.6.6. *Six*

$$\{ a:r \}$$

$$\infty ar-, \infty a:r$$

3.6.6.1.  $\infty ar-$  occurs before *poo* 'ten' and *kwa:w* 'measure'.

Ex. <i>ar-poo</i> (2.6)	$\rightarrow$ <i>aroo</i> 'sixty'
<i>ar-kwa:w</i>	'six <i>kwa:x</i> measure'

3.6.6.2.  $\infty a:r$  occurs elsewhere

Ex. <i>a:r</i>	'six'
<i>p-a:r</i>	'sixteen'
<i>a:r nu:r</i>	'six hundred'
<i>a:r so:fer</i>	'six thousand'
<i>a:r ak</i>	'six <i>ačok</i> measure'
<i>a:r moŋy</i>	'six o' clock'
<i>a:r silyx</i>	'six big measure'
<i>a:r a:r</i>	'six each'

3.6.7. *Seven*

$$\{ \bar{o}w \}$$

$$\infty a:w-, \infty \bar{o}w-$$

3.6.7.1.  $\infty a:w-$  occurs after *p-* denoting 'ten'

Ex. <i>p-a:w</i>	'seventeen'
------------------	-------------

3.6.7.2. ∞ *ōw-* occurs elsewhere

Ex. <i>ōw</i>	'seven'
<i>ōw-poo</i> (2.6) —> <i>ōwoθ</i>	'seventy'
<i>ōw nu:ɾ</i>	'seven hundred'
<i>ōw so:fer</i>	'seven thousand'
<i>ōw kwa:w</i>	'seven <i>kwa:x</i> measure'
<i>ōw silyx</i>	'seven big measure'

3.6.8. *Eight*

{ *ōt* }

∞ *u:t-* ∞ *ōt-*

3.6.8.1. ∞ *u:t-* occurs after *p-* denoting 'ten'

Ex. <i>p-u:t</i>	'eighteen'
------------------	------------

3.6.8.2. ∞ *ōt-* occurs elsewhere

Ex. <i>ōt</i>	'eight'
<i>ōt-poo</i> (2.5) —> <i>ōtfoθ</i>	'eighty'
<i>ōt nu:ɾ</i>	'eight hundred'
<i>ōt so:fer</i>	'eight thousand'
<i>ōt ak</i>	'eight <i>ačok</i> measure'
<i>ōt kwa:w</i>	'eight <i>kwa:x</i> measure'
<i>ōt silyx</i>	'eight big measure'
<i>ōt ōt</i>	'eight each'

3.6.9. *Nine*

{ *wīnboθ* }

∞ *e:ŋ-* ∞ *u:nboθ-*, ∞ *wīnbo-* ∞ *winboθ*

3.6.9.1.  $\infty e:\eta-$  occurs before *boø* 'ten'

Ex. *e:\etaboø* 'ninety'

3.6.9.2.  $\infty w\bar{i}nbo$  occurs before word juncture #

Ex. *w\bar{i}nbo nu:r* 'nine hundred'

*w\bar{i}nbo so:fer* 'nine thousand'

*w\bar{i}nbo po\eta m* 'nine old coin'

*w\bar{i}nbo kwa:w* 'nine *kwa:x* measure'

*w\bar{i}nbo silyx* 'nine big measure'

*w\bar{i}nbo-ak* (2.51,52)  $\rightarrow$  *w\bar{i}nba:k*  
'nine *ačok* measure'

3.6.9.3.  $\infty u:nboø$  occurs after *p-* denoting 'ten'

Ex. *pu:nboø* 'nineteen'

3.6.9.4.  $\infty w\bar{i}nboø$  occurs only as a numeral

Ex. *w\bar{i}nboø* 'nine'

3.6.10. *Ten*

{ *pot* }

$\infty pon-$ ,  $\infty poø-$ ,  $\infty boø-$ ,  $\infty p-$ ,  $\infty pot$

3.6.10.1.  $\infty pon-$  occurs as adjective base before one, two and three.

Ex. *pon w\bar{i}d* 'eleven'

*pon e:d* 'twelve'

*pon mu:d* 'thirteen'

3.6.10.2.  $\infty$  *poθ* occurs after *mu-*, *nal-*, *ar-*, *ōw-* *ī-* and *ōt-* denoting 'three', 'four', 'six', 'seven', 'two' and 'eight'.

Ex. <i>mupoθ</i>		'thirty'
<i>nalpoθ</i>		'forty'
<i>ar-poθ</i> (2.6)	—>	<i>aroθ</i> 'sixty'
<i>ōw-poθ</i> (2.6)	—>	<i>ōwoθ</i> 'seventy'
<i>ī-poθ</i> (2.5)	—>	<i>īfoθ</i> 'twenty'
<i>ōt-poθ</i> (2.5)	—>	<i>ōtfoθ</i> 'eighty'

3.6.10.3.  $\infty$  *boθ-* occurs after *e-*, *pu:n* and *e:n*

Ex. <i>e-boθ</i>		'fifty'
<i>pu:n-boθ</i>		'nineteen'
<i>e:n-boθ</i>		'ninety'

3.6.10.4.  $\infty$  *p-* occurs before *-a:ng*, *-u:j*, *-a:r*, *-a:w*, *u:t* and *-u:nboθ*.

Ex. <i>pa:ng</i>		'fourteen'
<i>pu:j</i>		'fifteen'
<i>pa:r</i>		'sixteen'
<i>pa:w</i>		'seventeen'
<i>pu:t</i>		'eighteen'
<i>pu:nboθ</i>		'nineteen'

3.6.10.5.  $\infty$  *pot* occurs elsewhere

Ex. <i>pot</i>		'ten'
<i>pot sofer</i>		'ten thousand'
<i>pot poꝛm</i>		'ten old coins'

<i>pot ak</i>	'ten <i>ačok</i> measure'
<i>pot kwa:w</i>	'ten <i>kwa:x</i> measure'

3.6.11. *Hundred*

{ *nu:r* }

~ *nu:r*

3.6.11.1. ~ *nu:r*

Ex. <i>nu:r</i>	' <u>hundred</u> '
<i>nu:r wiḍ</i>	'hundred and <u>one</u> '
<i>nu:r e:d</i>	'hundred and <u>two</u> '
<i>nu:r mu:d</i>	'hundred and <u>three</u> '
<i>nu:r no:ng</i>	'hundred and <u>four</u> '
<i>nu:r üj</i>	'hundred and <u>five</u> '
<i>nu:r a:r</i>	'hundred and <u>six</u> '
<i>nu:r öw</i>	'hundred and <u>seven</u> '
<i>nu:r öf</i>	'hundred and <u>eight</u> '
<i>nu:r wi:nboe</i>	'hundred and <u>nine</u> '
<i>nu:r poe</i>	'hundred and <u>ten</u> '
<i>nu:r ponwiḍ</i>	'hundred and <u>eleven</u> '
<i>nu:r pone:d</i>	'hundred and <u>twelve</u> '
<i>nu:r ponmu:d</i>	'hundred and <u>thirteen</u> '
<i>nu:r pa:ng</i>	'hundred and <u>fourteen</u> '
<i>nu:r pu:ŋ</i>	'hundred and <u>fifteen</u> '
<i>nu:r poe</i>	'hundred and <u>ten</u> '
<i>nu:r i:foe</i>	'hundred and <u>twenty</u> '

<i>nu:ɾ mupoo</i>	‘hundred and thirty’
<i>nu:ɾ nalpoo</i>	‘hundred and forty’
<i>nu:ɾ eboo</i>	‘hundred and fifty’
<i>nu:ɾ aɾoo</i>	‘hundred and sixty’
<i>nu:ɾ õwoo</i>	‘hundred and seventy’
<i>nu:ɾ õtfoo</i>	‘hundred and eighty’
<i>nu:ɾ e:ɲboo</i>	‘hundred and ninety’

3.6.12. *Thousand*

{ *so:fer* }

∞ *so:fer* ∞ *so:ferm*

3.6.12.1. ∞ *so:ferm*—occurs when it is followed by numerals.

Ex. <i>so:ferm wīd</i>	‘thousand and one’
<i>so:ferm e:d</i>	‘thousand and two’
<i>so:ferm mu:d</i>	‘thousand and three’
<i>so:ferm no:ng</i>	‘thousand and four’
<i>so:ferm üj</i>	‘thousand and five’
<i>so:ferm õt</i>	‘thousand and eight’
<i>so:ferm ifoo</i>	‘thousand and twenty’
<i>so:ferm nalpoo</i>	‘thousand and forty’
<i>so:ferm eboo</i>	‘thousand and fifty’
<i>so:ferm e:ɲboo</i>	‘thousand and ninety’

3.6.12.2. ∞ *so:fer* occurs elsewhere.

Ex. <i>o so:fer</i>	‘one thousand’
<i>e:d so:fer</i>	‘two thousand’

<i>mu:d so:fer</i>	‘three thousand’
<i>no:ng so:fer</i>	‘four thousand’
<i>ũj so:fer</i>	‘five thousand’
<i>a:r so:fer</i>	‘six thousand’
<i>öw so:fer</i>	‘seven thousand’
<i>öt so:fer</i>	‘eight thousand’
<i>wĩnbo so:fer</i>	‘nine thousand’
<i>so:fer o:ř</i>	‘thousand Todas’
<i>so:fer ĩr</i>	‘thousand buffaloes’

3.6.13. *Lakh*

{ *lačm* }

~ *lačm*

3.6.13.1 ~ *lačm*

Ex. <i>wĩd lačm</i>	‘one lakh’
<i>e:d lačm</i>	‘two lakhs’
<i>mu:d lačm</i>	‘three lakhs’
<i>wĩd lačm-t- pot so:fer</i> (2.7) —>	
<i>wĩd lač-t- pot so:fer</i>	‘one lakh and ten thousands’
<i>mu:d lačm-t- no:ng so:fer</i> (2.7) —>	
<i>mu:d lač-t no:ng so:fer</i>	‘Three lakhs and four thousands’
<i>no:ng lačm-t e:d so:fer</i> —>	
<i>no:ng lač-t e:d so:fer</i>	‘Four lakhs and two thousands’

*e:ḍ lačm-t üj so:fer* (2.7) —>  
*e:ḍ lač-t üj so:fer*  
 'Two lakhs and five thousands'

### 3.6.14. *Crore*

{ *kwī:ḍy* }

∞ *kwī:ḍy* ∞ *kwī:ḍym*

3.6.14.1. ∞ *kwī:ḍym* occurs when it is followed by the numeral lakhs.

Ex. *no:ng kwī:ḍym e:ḍ lačm* 'Four crores and two lakhs'  
*e:ḍ kwī:ḍym mu:ḍ lačm* 'Two crores and three lakhs'  
*üj kwī:ḍym öṭ lačm* 'Five crores and eight lakhs'

3.6.14.2. ∞ *kwī:ḍy* occurs elsewhere

Ex. *wīḍ kwī:ḍy* 'one crore'  
*e:ḍ kwī:ḍy* 'two crores'  
*mu:ḍ kwī:ḍy* 'three crores'  
*no:ng kwī:ḍy* 'four crores'  
*üj kwī:ḍy* 'five crores'  
*kwī:ḍy ɪr* 'crore buffaloes'

### 3.7. Derivative nouns

#### 3.7.1. Agentive suffix

St.

{ *-xo:ɾ* }

~ - *xo:ɾ*

3.7.1.1. ~ -xo:ɾ occurs, after the nouns *karm* etc as given below.

Ex. <i>karm-xo:ɾ-n</i>	'sinner'
<i>koɽy-xo:ɾ-n</i>	'clever fellow'
<i>kwaly-xo:ɾ-n</i>	'murderer'
<i>ogody-xo:ɾ-n</i>	'person who posses shop'
<i>koɽŋ-xo:ɾ-n</i>	'person with debt'
<i>poŋm-xo:ɾ-n</i> (2.7) —>	<i>poŋxo:ɾn</i>
	'rich man'
<i>aŝky-xo:ɾ-n</i>	'person who sells rice'
<i>kapoty-xo:ɾ-n</i>	'person who sells jaggery'
<i>eŋo:y-xo:ɾ-n</i>	'person who sells oil'
<i>kubly-xo:ɾ-n</i>	'person who sells blankets'
<i>toyl-xo:ɾ-n</i>	'Eucalyptus seller'
<i>poɽy-xo:ɾ-n</i>	'person who possessing or driving carts'
<i>so:roy-xo:ɾ-n</i>	'arrack seller'
<i>twi:ɽm-xo:ɾ-n</i> (2.7) —>	<i>twi:ɽxo:ɾn</i>
	'person who possess lands'
<i>paɽ-xo:ɾ-n</i>	'person who sells bangles'
<i>püɽy-xo:ɾ-n</i>	'person who sells tamarind'
<i>mī:n-xo:ɾ-n</i>	'person who sells fish'

This is a very productive derivation in the Toda language.

3.7.2. ~ -o:m occurs after the noun *kwīɽbīl-*

Ex. <i>kwīɽbīl-o:m</i>	'relatives'
------------------------	-------------

3.7.3. ~ *-upm* occurs after noun *koy-*

Ex. *koy-upm* 'signature'

3.7.4. ~ *-o:ʔ* occurs in the following

Ex. *püty o:ʔ* 'wise man'

*püen o:ʔ* 'stranger'

*soko:ʔmo:ʔ* 'sick person'

*modo:ʔ* 'Toda village people'

3.7.5. ~ *-my* occurs after the following stems

Ex. *per-my* 'greatness, fame'

*nat-my* (2.10) —> *nanny*  
'goodness'



# 4

## Verbs

4.0. Verbs are those which can take or are capable of taking tense suffixes. Verbal nouns and participial nouns take case suffixes also. Since they are derived from the verb stems, they are treated under verbs.

### 4.1.1. Transitive

$V_{\text{intr}_2}$  —

{ -t- }

$\infty$ -t-    $\infty$ -c-    $\infty$ -f-

4.1.1.1.  $\infty$ -c- occurs after all the intransitive<sub>2</sub> of *y* class (4.22.1.3.2)  $\emptyset$  class (4.22.2.3.2) *t* class (4.22.3.3.2) and after the intransitive<sub>2</sub> of *d* class (4.22.4.3.2).

Ex. *kak-c*

'to make to vomit'

<i>o:d-c</i>			'to make to dance'
<i>mu:x-c</i>			'to destroy'
<i>o:r-c</i>			'to settle dispute'
<i>ti:r-c</i>			'to finish'
<i>ko:y-c</i>	(2.26)	—>	<i>ko:c</i> 'to heat'
<i>kody-c</i>	(2.26)	—>	<i>koɖc</i> 'to make to disappear'
<i>tīry-c</i>	(2.26)	—>	<i>tīrc</i> 'to translate'
<i>naɖc</i>			'to conduct'
<i>toɳy-c</i>	(2.26)	—>	<i>toɳc</i> 'to make cool, calm'
<i>pīxy-c</i>	(2.26)	—>	<i>pīxc</i> 'to tighten'
<i>pūry-c</i>	(2.26)	—>	<i>pūrc</i> 'to fill'
<i>pīry-c</i>	(2.26)	—>	<i>pīrc</i> 'to make spring forth'
<i>tūɣy-c</i>	(2.26)	—>	<i>tūɣc</i> 'to calm'
<i>kaɬ-c</i>	(2.9)	—>	<i>kalc</i> 'to teach'
<i>kōɾ-c</i>	(2.11)	—>	<i>kōɖc</i> 'to destroy'
<i>twī:ɣ-c</i>	(2.9)	—>	<i>twī:lc</i> 'to defeat'
<i>mony-c</i>	(2.26)	—>	<i>monc</i> 'to forgive'
<i>pīɾ-c</i>			'to destroy'
<i>o:poɾ-c</i>			'to catch'
<i>tōɖxōɾ-c</i>			'to make tired'
<i>nil-c</i>			'to stop'

4.1.1.2.  $\infty-t-$  occurs after the intransitive<sub>2</sub> of *y* class (4.23.1.3.1),  $\emptyset$  class (4.23.2.3.1) and after the intransitive<sub>2</sub> of *d* class (4.23.4.3.1)

- Ex. *alx-t* (2.3,4) —> *alk* 'to shake'
- ī:x-t* (2.3,4) —> *ī:k* 'to put down burden'

<i>oḍg-t</i>	(2.3,4)	—>	<i>oḍk</i>	‘to subdue’
<i>wīrg-t</i>	(2.3,4)	—>	<i>wīrk</i>	‘to crush’
<i>tīrb-t</i>	(2.3,4)	—>	<i>tīrp</i>	‘to turn (key)’
<i>o:d-t</i>	(2.3,4)	—>	<i>o:t</i>	‘to shake’
<i>ku:r-t</i>	(2.3,4)	—>	<i>ku:t</i>	‘to join’
<i>ni:r-t</i>	(2.3,4)	—>	<i>ni:t</i>	‘to stretchout’
<i>mo:r-t</i>	(2.3,4)	—>	<i>mo:t</i>	‘to change (way)’
<i>tō:r-t</i>	(2.3,4)	—>	<i>tō:t</i>	‘to make improve (in health)’
<i>ōḍ-t</i>	(2.12)	—>	<i>ōrt</i>	‘to arouse’
<i>kaḍ-t</i>	(2.12)	—>	<i>kart</i>	‘to take cross’
<i>naṛ-t</i>		—>		‘to make to walk’
<i>sō:r-t</i>	(2.13)	—>	<i>sō:t</i>	‘to make to reach’
<i>u:l-t</i>	(2.1,2)	—>	<i>u:t</i>	‘to roll’
<i>tu:l-t</i>	(2.1,2)	—>	<i>tu:t</i>	‘to rollup’
<i>pī:l-t</i>	(2.1,2)	—>	<i>pī:t</i>	‘to make tumble over’
<i>pu:l-t</i>	(2.1,2)	—>	<i>pu:t</i>	‘to tie around some else’s neck’
<i>kiskwīl-t</i>	(2.1,2)	—>	<i>kiskwīt</i>	‘to tickle’
<i>ni:l-t</i>	(2.1,2)	—>	<i>ni:t</i>	‘to stretchout’
<i>pe:l-t</i>	(2.1,2)	—>	<i>pe:t</i>	‘to frighten away (buffalo)’
<i>ko:n-t</i>	(2.1,2)	—>	<i>ko:t</i>	‘to show’
<i>no:l-t</i>	(2.3,4)	—>	<i>no:t</i>	‘to make to become wet’

4.1.1.3. ∞ -f- occurs elsewhere

Ex. *ōḍ-f* (2.12) —> *ōrf* ‘to arouse from sleep’

<i>kwal-f</i>	'to make to be emaciated'
<i>aṛ-f</i>	'to shut'
<i>twad-f</i>	'be polluted'
<i>waṛ-f</i>	'to break'
<i>taṛ-f</i>	'to prevent'
<i>nen-f</i>	'to make to think'
<i>pax-f</i>	'be divided'
<i>kwaṛ-f</i>	'to cut'
<i>peṭ-f</i>	'to grow'
<i>kaṛ-f</i>	'to tighten'
<i>neṛ-f</i>	'to fill'

## 4.1.2. Causative

 $S_1-$ 

{ -eṭ }

~ -eṭ<sup>1</sup>

## 4.1.2.1. ~ -eṭ

Ex. <i>tin-eṭ</i>	'to cause to eat'
<i>maṛ-eṭ</i>	'to cause to forget'
<i>uṇ-eṭ</i>	'to cause to drink'
<i>īr-eṭ</i>	'to cause to sit'
<i>naṛ-eṭ</i>	'to cause to walk'

1. Prof. M. B. Emeneau connects this to Tamil-Malayalam *erṛu* 'to strike, throw (as with a sling)'. This might originally be a periphrastic construction involving the infinite form of a verb plus *erṛu*.

<i>kaṭ-eṭ</i>	'to cause to learn'
<i>ōṣṭ-eṭ</i>	'to cause to say'
<i>kīy-eṭ</i>	'to cause to do'
<i>nīl-eṭ</i>	'to cause to stand'

#### 4.2. Verbal derivative<sup>1</sup>

Verbal derivative is not productive in Toda. There are many verbal derivative suffixes like *-p -f -il -t* etc. which occur after verbal stems. The number of verbal stems to which each of these derivative suffixes added is limited.

St.

##### 4.2.1. *The deed*

{ *-p* }

*∞-ky ∞-ḡy ∞-y ∞-f ∞-m ∞-p*

4.2.1.1. *∞-ky* occurs after the verbs *nob-*, *oj-*, and *ko:ṇ-*

Ex. <i>nob-ky</i>	'belief'
<i>oj-ky</i>	'fear'
<i>ko:ṇ-ky</i>	'offering to Hindu temple'

---

<sup>1</sup> Verbal derivative is a non-productive morpheme and so the allomorphs of the various verbal derivative suffixes are morphologically conditioned.

See: Dr. S. Agesthalingom, *Description of the language of Patirruppattu*, Ph.D. Dissertation, Kerala Univ., 1961.

See also: Dr. S. V. Shanmugam, *The Language of Tamil Inscriptions (1350 to 1700 A.D.)*, Ph.D. Dissertation, Annamalai Univ., 1968.

4.2.1.2.  $\infty$ -*f* occurs after the verb *aḡ-*

Ex. *aḡ-f* 'measurement'

4.2.1.3.  $\infty$ -*əy* occurs after the verb *mar-*

Ex. *mar-əy* 'forgetfulness'

4.2.1.4.  $\infty$ -*y* occurs after the verbs *po:t-* and *pax-*

Ex. *po:t-y* 'bed'

*pax-y* 'division'

4.2.1.5.  $\infty$ -*m* occurs after the verbs *ōḡ-*, *-ku:t* and *wī:d-*

Ex. *ōḡ-m* 'counting'

*ku:t-m* 'meeting of assembly'

*wī:d-m* 'running'

4.2.1.6.  $\infty$ -*p* occurs after the verbs *uny-*, *nen-*, and *moḡy-*

Ex. *uny-p* 'a thought'

*nen-p* "

*moḡy-p* 'forgiveness'

#### 4.2.2. Resultive nominals

{ -*f* }

$\infty$ -*f*,  $\infty$ -*mo:ḡm*,  $\infty$ -*xīn*  $\infty$ -*n*  $\infty$ -*p*

4.2.2.1.  $\infty$ -*f* occurs after the verbs *ke:ḡ* and *neḡ-*

Ex. *ke:ḡ-f* 'news, word'

*neḡ-f* 'full moon'

4.2.2.2.  $\infty$ -*p* occurs after the verb *naḡ-*

Ex. *naḡ-p* 'character'

4.2.2.3.  $\infty - mo:nm$  occurs after the verb *ti:r-*

Ex. *ti:r-mo:nm* 'decision'

4.2.2.4.  $\infty -x\bar{i}n$  occurs after the verb *toḷ-*

Ex. *toḷ-xīn* 'goldsmith'

4.2.2.5.  $\infty n$  occurs after the verb *koḷ-*

Ex. *koḷ-n* (2.17)  $\rightarrow$  *koḷn* 'thief'

#### 4.2.3. Action nominals

{ -īl }

~ -īl

4.2.3.1. ~īl occurs after the verbs *pīk-* *kasp-* *ko:f-* *ku:s-*  
and *kwīj-*

Ex. *pīk-īl* 'cough'

*kasp-īl* 'transgression of dairy rules'

*ko:f-īl* 'act of watching'

*ku:s-īl* 'a heap'

*kwīj-īl* 'ridicule'

#### 4.2.4. Resultant-object nominals

{ -t }

$\infty -t$ ,  $\infty -fu$ ,  $\infty -īḷe:r$ ,  $\infty fy$ ,  $\infty \emptyset$ ,  $\infty xuḷy$

4.2.4.1.  $\infty -fu$  occurs after this *aṛy-*

Ex. *aṛy-fu*  $\rightarrow$  *aṛyfu* 'knowledge'

4.2.4.2.  $\infty$ -*ĩte:r* occurs after the verb *pi:k-*

Ex. *pi:k-ĩte:r* 'a lie'

4.2.4.3.  $\infty$ -*fy* occurs after the verb *kaē*

Ex. *kaē-fy* (2.9)  $\rightarrow$  *kalfy* 'education'

4.2.4.4.  $\infty$ -*xuēy* occurs after the verb *oj-*

Ex. *oj-xuēy* 'coward'

4.2.4.5.  $\infty$ - $\emptyset$  occurs after the verb *pu:t*

Ex. *pu:t- $\emptyset$*   $\rightarrow$  *pu:t* 'a lock'

4.2.4.6.  $\infty$ -*t* occurs after the verbs *oŕy-*, *ĩt-*, *karc-*, *pe:s-*, *wĩ:əy-* and *neŕoŕy*.

(*up*) *oŕy-t* (2.26)  $\rightarrow$  (*up*) *oŕt*  
'act of pouring salt for the buffalo'

(*pĩs*) *ĩt-t* 'bow giving ceremony during women's pregnancy'

(*pəp*) *karc-t* 'act of purifying the coagulant'

(*poēy*) *pe:s-t* 'act of thatching the dairy'

(*pok*) *wĩ:əy-t* (2.26)  $\rightarrow$  *pok wĩ:ət*  
'act of reading' (book)

(*mađ*) *neŕoŕy-t* (2.26)  $\rightarrow$  (*mađ*) *neŕoŕt*  
'act of salutation (head)'

4.2.5. *The instrument or consequence of action*

{ -*xu:* }

$\infty$  -*xu:*  $\infty$  -*xuēy*

4.2.5.1  $\infty$  -*xu*: occurs after the verb *müc-*

Ex. *müc-xu*: 'lid'

4.2.5.2.  $\infty$  -*xuṣy* occurs after the verb *pu:t-*

Ex. *pu:t-xuṣy* 'cloak'

### 4.3. Verb classes

When we look into the conjugational system of Toda verbs, we come across two types of stems, which we call simple stem (labelled as)  $S_1$  and secondary stem (labelled as)  $S_2$ . Verbal base ( $S_1$ ) is basis for all verb construction. In Toda, verbs have a secondary stem ( $S_2$ ) which forms the basis for the past tense and of the present-future tense (as well as of some other formations). The secondary stem which corresponds to the past stem of the other South Dravidian languages is formed by adding one of the following suffixes to the verb base (1) -*ə*- (2) -*t*- (3) -*d*- and (4) -*y*-. Toda has in the  $S_2$  stem the following classes<sup>1</sup>. By adding these, certain changes take place. These changes are dealt in the morphophonemic section. (See Rules 2.20-2 40).

$$1) S_2 = S_1 + y$$

$$2) S_2 = S_1 + \emptyset$$

$$3) S_2 = S_1 + t$$

$$4) S_2 = S_1 + d$$

#### 4.3.1. Tense suffixes

{  $S_2$  - }

1 M. B. Emeneau, 'The South Dravidian Languages,' *Journal of the American Oriental Society*, 87, p. 365-412, 1967.

4.3.1.1. *Non-past (Present-Future)*

$$\{ -p- \}$$

$$\infty -\emptyset- \quad \infty -t- \quad \infty -p-$$

4.3.1.1.1.  $\infty -\emptyset-$  occurs after the secondary stem  $S_2$  and before personal termination in declaratives.

Ex. <i>pod-<math>\emptyset</math>-pin-i</i>	—>	<i>podpini</i>	‘come-I’
<i>pod-<math>\emptyset</math>-pim-i</i>	—>	<i>podpimi</i>	‘come-we (excl.)’
<i>pod-<math>\emptyset</math>-pum-i</i>	—>	<i>podpumi</i>	‘come-we (incl.)’
<i>pod-<math>\emptyset</math>-p-i</i>	—>	<i>podpi</i>	‘come-you’
<i>pod-<math>\emptyset</math>-tš-i</i>	—>	<i>podtši</i>	‘come-you (pl.)’
<i>pod-<math>\emptyset</math>-t-i</i>	—>	<i>podti</i>	‘comes-he/she/it’
<i>pod-<math>\emptyset</math>-t-i</i>	—>	<i>podti</i>	‘come-they’
<i>pi:-<math>\emptyset</math>-pin-i</i>	—>	<i>pi:pini</i>	‘go-I’
<i>pi:-<math>\emptyset</math>-pim-i</i>	—>	<i>pi:pimi</i>	‘go-we (excl.)’
<i>pi:-<math>\emptyset</math>-pum-i</i>	—>	<i>pi:pumi</i>	‘go-we (incl.)’
<i>pi:-<math>\emptyset</math>-p-i</i>	—>	<i>pi:pi</i>	‘go-you’
<i>pi:-<math>\emptyset</math>-tš-i</i>	—>	<i>pi:tši</i>	‘go-you (pl.)’
<i>pi:-<math>\emptyset</math>-t-i</i>	—>	<i>pi:ti</i>	‘goes-he/she/it’
<i>pi:-<math>\emptyset</math>-t-i</i>	—>	<i>pi:ti</i>	‘go-they’
<i>tīd-<math>\emptyset</math>-pin-i</i>	—>	<i>tīdpini</i>	‘eat-I’
<i>tīd-<math>\emptyset</math>-pim-i</i>	—>	<i>tīdpimi</i>	‘eat-we (excl.)’
<i>tīd-<math>\emptyset</math>-pum-i</i>	—>	<i>tīdpumi</i>	‘eat-we (incl.)’
<i>tīd-<math>\emptyset</math>-p-i</i>	—>	<i>tīdpi</i>	‘eat-you’
<i>tīd-<math>\emptyset</math>-tš-i</i>	—>	<i>tīdtši</i>	‘eat-you (pl.)’
<i>tīd-<math>\emptyset</math>-t-i</i>	—>	<i>tīdti</i>	‘eats-he/she/it’

<i>tīd-Ø-t-i</i>	—>	<i>tīd̄ti</i>	‘eat-they’
<i>pīt-Ø-pin-i</i>	—>	<i>pīt̄pini</i>	‘carry-I’
<i>pīt-Ø-pim-i</i>	—>	<i>pīt̄pimi</i>	‘carry-we (excl.)’
<i>pīt-Ø-pum-i</i>	—>	<i>pīt̄pumi</i>	‘carry-we (incl.)’
<i>pīt-Ø-p-i</i>	—>	<i>pīt̄pi</i>	‘carry-you’
<i>pīt-Ø-tš-i</i>	—>	<i>pīt̄tši</i>	‘carry-you (pl.)’
<i>pīt-Ø-t-i</i>	—>	<i>pīt̄ti</i>	‘carries-he/she/it’
<i>pīt-Ø-t-i</i>	—>	<i>pīt̄ti</i>	‘carry-they’
<i>uḍ-Ø-pin-i</i>	—>	<i>uḍpini</i>	‘drink-I’
<i>uḍ-Ø-pim-i</i>	—>	<i>uḍpimi</i>	‘drink-we (incl.)’
<i>uḍ-Ø-pum-i</i>	—>	<i>uḍpumi</i>	‘drink-we (excl.)’
<i>uḍ-Ø-p-i</i>	—>	<i>uḍpi</i>	‘drink-you’
<i>uḍ-Ø-tš-i</i>	—>	<i>uḍtši</i>	‘drink-you (pl.)’
<i>uḍ-Ø-t-i</i>	—>	<i>uḍti</i>	‘drinks-he/she/it’
<i>uḍ-Ø-t-i</i>	—>	<i>uḍti</i>	‘drink-they’
<i>kaṛø-Ø-pin-i</i>	—>	<i>kaṛøpini</i>	‘milk-I’
<i>kaṛø-Ø-pim-i</i>	—>	<i>kaṛøpimi</i>	‘milk-we (excl.)’
<i>kaṛø-Ø-pum-i</i>	—>	<i>kaṛøpumi</i>	‘milk-we (incl.)’
<i>kaṛø-Ø-p-i</i>	—>	<i>kaṛøpi</i>	‘milk-you’
<i>kaṛø-Ø-tš-i</i>	—>	<i>kaṛøtši</i>	‘milk-you (pl.)’
<i>kaṛø-Ø-t-i</i>	—>	<i>kaṛøti</i>	‘milks-he’
<i>kaṛø-Ø-t-i</i>	—>	<i>kaṛøti</i>	‘milk-they’

S<sub>1</sub>— (caus.)

<i>tīn-eḷ-Ø-pin-i</i>	—>	<i>tīneḷpini</i>	‘to cause to eat-I’
<i>tīn-eḷ-Ø-pim-i</i>	—>	<i>tīneḷpimi</i>	‘to cause to eat-we (excl.)’

<i>tīn-eḷ-ḡ-pum-i</i>	—>	<i>tīneḷpumi</i>	‘to cause to eat-we (incl.)’
<i>tīn-eḷ-ḡ-p-i</i>	—>	<i>tīneḷpi</i>	‘to cause to eat-you’
<i>tīn-eḷ-ḡ-tš-i</i>	—>	<i>tīneḷtši</i>	‘to cause to eat-you (pl.)’
<i>tīn-eḷ-ḡ-t-i</i>	—>	<i>tīneḷti</i>	‘to cause to eat-he/she’
<i>tīn-eḷ-ḡ-t-i</i>	—>	<i>tīneḷti</i>	‘to cause to eat-they’
<i>naḷ-eḷ-ḡ-pin-i</i>	—>	<i>naḷeḷpini</i>	‘to cause to walk-I’
<i>naḷ-eḷ-ḡ-pim-i</i>	—>	<i>naḷeḷpimi</i>	‘to cause to walk-we (excl.)’
<i>naḷ-eḷ-ḡ-pum-i</i>	—>	<i>naḷeḷpumi</i>	‘to cause to walk-we (incl.)’
<i>naḷ-eḷ-ḡ-p-i</i>	—>	<i>naḷeḷpi</i>	‘to cause to walk-you’
<i>naḷ-eḷ-ḡ-ttš-i</i>	—>	<i>naḷeḷtši</i>	‘to cause to walk-you (pl.)’
<i>naḷ-eḷ-ḡ-t-i</i>	—>	<i>naḷeḷti</i>	‘to cause to walk-he/she’
<i>naḷ-eḷ-ḡ-t-i</i>	—>	<i>naḷeḷti</i>	‘to cause to walk-they’

4.3.1.1.2.  $\infty$  -p occurs after secondary stem ( $S_2$ ) and before o:ḷ in participial noun.

Ex. <i>pod-p-o:ḷ</i>	—>	<i>podpo:ḷ</i>	‘person who comes’
<i>kīs-p-o:ḷ</i>	—>	<i>kīs-p-o:ḷ</i>	‘person who does’
<i>pi:-p-o:ḷ</i>	—>	<i>pi:po:ḷ</i>	‘person who goes’
<i>uḍ-p-o:ḷ</i>	—>	<i>uḍpo:ḷ</i>	‘person who drinks’
<i>ōštiv-p-o:ḷ</i>	—>	<i>ōštypo:ḷ</i>	‘person who says’

<i>tīd-p-o:ḥ</i>	—>	<i>tīdpo:ḥ</i>	‘person who eats’
<i>kaṛṇ-p-o:ḥ</i>	—>	<i>kaṛṇpo:ḥ</i>	‘person who milks’

4.3.1.1.3.  $\infty$ -t- occurs after secondary stem  $S_2$  and before relative participle suffix  $-\emptyset$  in relative participle<sub>1</sub>.

Ex. <i>kaṭ-t-ḥ</i>	—>	<i>kaṭt</i>	‘that studying’
<i>pod-t-ḥ</i>	—>	<i>podt</i>	‘that coming’
<i>kīs-t-ḥ</i>	—>	<i>kīst</i>	‘that doing’
<i>pūṣoḍṇ-t-ḥ</i>	—>	<i>pūṣoḍṇt</i>	‘that calling’
<i>nīd-t-ḥ</i>	—>	<i>nīdt</i>	‘that standing’

#### 4.3.1 2. Past tense

In Toda language the past tense and the present-future (as well as some other formations) are formed on a special stem that may be called the ‘secondary stem’ ( $S_2$  of Emeneau). This secondary stem historically corresponds to the past stem of Tamil–Malayalam and some other languages. The secondary stem is formed by adding one of the following suffixes to the verb base 1.  $\emptyset$  2. *t* 3. *d* and 4. *y*. ‘In South Dravidian Toda is the only language which retains in full working order as part of the past tense formation the sibilant suffix that must be reconstructed as part of past tense apparatus for Proto-Dravidian’<sup>1</sup>.

It has several sibilant allomorphs *s z*, *ṣ ẓ*, *ṣ̣ ẓ̣*, *ṣ̥ ẓ̥* and  $\emptyset$  *s* has been taken as base and all other sibilants have been explained as phonologically conditioned alternants. For details see the sandhi rules S.2.41–2.49.

1. Emeneau, M.B. ‘Toda, A Dravidian language’ *Transactions of the Philological Society* p. 46, 1957.

$$\left\{ \begin{array}{l} S_2- \\ S_1-(\text{Tr.}) \end{array} \right\}$$

$$\left\{ -s- \right\}$$

$$\sim -s- \infty -\emptyset-$$

4.3.1.2.1.  $\infty -\emptyset-$  occurs after the secondary stem ( $S_2$ ) and before relative participle suffix  $-foy$ .

Ex. <i>kaʃ-∅-foy</i>	—> <i>kaʃfoy</i>	‘studied’
<i>pod-∅-foy</i>	—> <i>podfoy</i>	‘came’
<i>naʃe-∅-foy</i>	—> <i>naʃefoy</i>	‘walked’
<i>kīś-∅-foy</i>	—> <i>kīśfoy</i>	‘did’
<i>kaʃe-∅-foy</i>	—> <i>kaʃefoy</i>	‘milked’

4.3.1.2.2.  $\sim -s-$  occurs elsewhere.

Ex. <i>nene-s-pin-i</i> (2.41)	—> <i>nenspini</i>	‘thought-I’
<i>pūṣoḍe-s-pin-i</i> (2.41)	—> <i>pūṣoḍspini</i>	‘called-I’
<i>paʃe-s-pin-i</i> (2.41)	—> <i>paʃspini</i>	‘wrote-I’
<i>kaʃe-s-pin-i</i> (2.41)	—> <i>kaʃspini</i>	‘milked-I’
<i>aʃt-s-pin-i</i> (2.41)	—> <i>aʃspini</i>	‘cut-I’
<i>monc-s-pin-i</i> (2.41)	—> <i>monspini</i>	‘forgave-I’

<i>umc-s-pin-i</i>	(2.41)	
	—>	<i>unspini</i> 'thought-I'
<i>ars-s-pin-i</i>	(2.18)	
	—>	<i>arspini</i> 'knew-I'
<i>pe:s-s-pin-i</i>	(2.18)	
	—>	<i>pe:spini</i> 'thatched-I'
<i>pīrs-s-pin-i</i>	(2.18)	
	—>	<i>pīrspini</i> 'demolised-I'
<i>mürs-s-pin-i</i>	(2.18)	
	—>	<i>mürspini</i> 'broke-I'
<i>kīs-s-pin-i</i>	(2.18)	
	—>	<i>kīspini</i> 'did-I'
<i>pod-s-pin-i</i>	(2.42,49)	
	—>	<i>pozpini</i> 'came-I'
<i>tod-s-pin-i</i>	(2.42,49)	
	—>	<i>tozpini</i> 'gave-I'
<i>sō:d-s-pin-i</i>	(2.42,49)	
	—>	<i>sō:zpini</i> 'arrived-I'
<i>u:d-s-pin-i</i>	(2.42,49)	
	—>	<i>u:zpini</i> 'disappeared-I'
<i>kaṭ-s-pin-i</i>	(2.43,49)	
	—>	<i>kaṣpini</i> 'learnt-I'
<i>mū:neṭ-s-pin-i</i>	(2.43,49)	
	—>	<i>mu:neṣpini</i> 'liked-I'
<i>twī:ṭy-s-pin-i</i>	(2.43,49)	
	—>	<i>twī:ṣpini</i> 'defeated-I'
<i>wī:ṭy-s-pin-i</i>	(2.26,43,49)	
	—>	<i>wī:ṣpini</i> 'drove calf from udder-I'

- tō:ty-s-pin-i* (2.26,43,49)  
 —> *tō:špini* ‘made to improve (in health)-I’
- kwad-s-pin-i* (2.44,49)  
 —> *kwazpini* ‘ran in circle-I’
- ka:d-s-pin-i* (2.44,49)  
 —> *ka:zpini* ‘fell from the tree-I’
- te:d-s-pin-i* (2.44,49)  
 —> *te:zpini* ‘did (work) - I’
- nīd-s-pin-i* (2.44,49)  
 —> *nīzpini* ‘stood-I’
- īd-s-pin-i* (2.44,49)  
 —> *īzpini* ‘said-I’
- ko:d-s-pin-i* (2.44,49)  
 —> *ko:zpini* ‘vomitted-I’
- e:mo:ty-s-pin-i* (2.26,45,49)  
 —> *e:mo:špini* ‘deceived-I’
- pīty-s-pin-i* (2.26,45,49)  
 —> *pīšpini* ‘sowed (seed)-I’
- pinty-s-pin-i* (2.26,45,49)  
 —> *pīnšpini* ‘asked-I’
- ki:č-s-pin-i* (2.45,49)  
 —> *ki:špini* ‘combed-I’
- ko:č-s-pin-i* (2.45,49)  
 —> *ko:špini* ‘boiled-I’
- ūrpy-s-pin-i* (2.26,45)  
 —> *ūrpšpini* ‘played (puxury)-I’
- ašpy-s-pin-i* (2.26,45)  
 —> *ašpšpini* ‘cleaned-I’

<i>noby-s-pin-i</i> (2.26,45)	—> <i>nobšpini</i>	'believed-I'
<i>tīrby-s-pin-i</i> (2.26,45)	—> <i>tīrbšpini</i>	'twisted-I'
<i>kufy-s-pin-i</i> (2.26,45)	—> <i>kufšpini</i>	'pounded (clothes in washing)-I'
<i>upy-s-pin-i</i> (2.26,45)	—> <i>upšpini</i>	'agreed-I'
<i>kīdy-s-pin-i</i> (2.26,46,49)	—> <i>kīžpini</i>	'sprinkled-I'
<i>tīdy-s-pin-i</i> (2.26,46,49)	—> <i>tīžpini</i>	'made straight (crookedness)-I'
<i>udy-s-pin-i</i> (2.26,46,49)	—> <i>užpini</i>	'smeared-I'
<i>kwīj-s-pin-i</i> (2.46,49)	—> <i>kwīžpini</i>	'ridiculed-I'
<i>ni: j-s-pin-i</i> (2.46,49)	—> <i>ni:žpini</i>	'swam-I'
<i>pu: j-s-pin-i</i> (2.46,49)	—> <i>pužpini</i>	'worshipped-I'
<i>pīd j-s-pin-i</i> (2.46,49)	—> <i>pīdžpini</i>	'released-I'
<i>oť-s-pin-i</i> (2.47,49)	—> <i>ošpini</i>	'cooked-I'
<i>pīt-s-pin-i</i> (2.47,49)	—> <i>pīšpini</i>	'left-I'

- poṭ-s-pin-i* (2.47,49)  
—> *poṣpini* ‘laid down-I’
- a:foṭ-ṣ-pin-i* (2.47,49)  
—> *a:foṣpini* ‘talked-I’
- tōḍxōṭ-s-pin-i* (2.47,49)  
—> *tōḍxōṣpini* ‘tired-I’
- īṭ-s-pin-i* (2.47,49)  
—> *īṣpini* ‘put-I’
- wī:rīṭ-s-pin-i* (2.47,49)  
—> *wī:rīṣpini* ‘listerned-I’
- kiskwīṭy-s-pin-i* (2.26,47,49)  
—> *kiswīṣpini* ‘tickled-I’
- nwī:ṭy-s-pin-i* (2.26,47,49)  
—> *nwī:ṣpini* ‘looked-I’
- oṭy-s-pin-i* (2.26,47,49)  
—> *oṣpini* ‘poured-I’
- koṭy-s-pin-i* (2.26,47,49)  
—> *koṣpini* ‘built (house)-I’
- mu:ku:ṭy-s-pin-i* (2.26,47,49)  
—> *mu:ku:ṣpini* ‘met-I’
- puk-s-pin-i* (2.47)  
—> *pukṣpini* ‘entered-I’
- ōoky-s-pin-i* (2.26,47)  
—> *ōokṣpini* ‘jumped-I’
- kalky-s-pin-i* (2.26,47)  
—> *kalkṣpini* ‘stirred up-I’
- moṛky-s-pin-i* (2.26,47)  
—> *moṛkṣpini* ‘folded-I’

<i>pušky-s-pin-i</i> (2.26,47)	—>	<i>puškypini</i>	‘boiled (potato)-I’
<i>nī:d-s-pin-i</i> (2.48,49)	—>	<i>nī:zpini</i>	‘peeped over I’
<i>kwīd-s-pin-i</i> (2.48,49)	—>	<i>kwīzpini</i>	‘carried (corpse)-I’
<i>kīskwīd-s-pin-i</i> (2.48,49)	—>	<i>kīskwīzpini</i>	‘tickled-I’
<i>teškwīd-s-pin-i</i> (2.48,49)	—>	<i>teškwīzpini</i>	‘hugged-I’
<i>pī:d-s-pin-i</i> (2.48,49)	—>	<i>pī:zpini</i>	‘tumbledover-I’
<i>oḍ-s-pin-i</i> (2.48,49)	—>	<i>o:zpini</i>	‘ruled-I’
<i>nö:d-s-pin-i</i> (2.48,49)	—>	<i>nö:zpini</i>	‘made robe of bark-I’
<i>pu:d-s-pin-i</i> (2.48,49)	—>	<i>pu:zpini</i>	‘wore around neck-I’
<i>koḍ-s-pin-i</i> (2.48,49)	—>	<i>kozpini</i>	‘looked-I’
<i>uḍ-s-pin-i</i> (2.48,49)	—>	<i>uzpini</i>	‘drank-I’
<i>o:dy-s-pin-i</i> (2.26,48,49)	—>	<i>o:zpini</i>	‘danced-I’

## 4.4. Prohibitive

Singular and plural

S<sub>2</sub>—

{ o- }

~ -o-

## 4.4.1. ~ -o-

Ex. <i>pod-o-t-i</i>	—> <i>podoti</i>	‘Do not come-you (sg.)’
<i>pī:-o-t-i</i>	—> <i>pi:oti</i>	‘Do not go-you (sg.)’
<i>naʀe-o-t-i</i>	—> <i>naʀeoti</i>	‘Do not walk-you (sg.)’
<i>tīd-o-t-i</i>	—> <i>tīdoti</i>	‘Do not eat-you (sg.)’
<i>ōšty-o-t-i</i> (2.26)	—> <i>ōštoʔi</i>	‘Do not say-you (sg.)’
<i>ko:t-o-t-i</i>	—> <i>koʔoti</i>	‘Do not show-you (sg.)’
<i>nwī:ty-o-t-i</i> (2.26)	—> <i>nwī:toʔi</i>	‘Do not see-you (sg.)’
<i>kwī:ʔt-o-t-i</i>	—> <i>kwīʔtoʔi</i>	‘Do not give-you (sg.)’
<i>wī:d-o-t-i</i>	—> <i>wī:doʔi</i>	‘Do not run-you (sg.)’
<i>pod-o-s-i</i>	—> <i>podosi</i>	‘Do not come-you (pl.)’
<i>tīd-o-s-i</i>	—> <i>tīdosi</i>	‘Do not eat-you (pl.)’
<i>pī:-o-s-i</i>	—> <i>pi:osi</i>	‘Do not go-you (pl.)’
<i>ko:t-o-s-i</i>	—> <i>ko:ʔosi</i>	‘Do not show-you (pl.)’
<i>nīd-o-s-i</i>	—> <i>nīdosi</i>	‘Do not stand-you (pl.)’
<i>poʔ-o-s-i</i>	—> <i>poʔosi</i>	‘Do not lie down-you (pl.)’
<i>uɖ-o-s-i</i>	—> <i>uɖosi</i>	‘Do not drink-you (pl.)’
<i>nwī:ty-o-s-i</i> (2.26)	—> <i>nwī:ʔosi</i>	‘Do not look (pl.)’

## 4.5. Negative

There are two types of negative in Toda language. **Neg<sub>1</sub>** denotes generally past negative; **Neg<sub>2</sub>** denotes the

present-future<sub>2</sub> negative. Neg<sub>2</sub> is discussed under 4.17 because it differs from Neg<sub>1</sub> in structure (position class).

#### 4.5.1. Negative<sub>1</sub>

$$S_1 \text{ ---Neg- } \left\{ \begin{array}{l} \text{Rel. part.} \\ \text{Verbal part.} \\ \text{Personal sfx.} \end{array} \right\}$$

$$\left\{ \text{-o-} \right\}$$

$$\infty \text{ -o-}$$

4.5.1.1.  $\infty \text{ -o-}$  occurs after the verbal base ( $S_1$ ) and before relative participle suffix *-foy*, verbal participle *-ə* and personal suffixes.

Ex. <i>nwī:t-o-foy</i>	'not seeing'
<i>pint-o-foy</i>	'not asking'
<i>kīy-o-foy</i>	'not doing'
<i>a:foɾ-o-foy</i>	'not talking'
<i>par-o-foy</i>	'not writing'
<i>uŋ-o-foy</i>	'not drinking'
<i>kaɬ-o-foy</i>	'not studying'
<i>po:r-o-foy</i>	'not coming'
<i>pī:x-o-foy</i>	'not going'
<i>ko:ŋ-o-foy</i>	'not looking'
<i>öšt-o-foy</i>	'not telling'
<i>tīn-o-foy</i>	'not eating'
<i>kaɾ-o-foy</i>	'not milking'

<i>naṛ-o-foy</i>	‘not walking’
<i>kaṛ-o-foy</i>	‘not churning’
<i>kīy-o-ø</i>	‘without doing’
<i>pint-o-ø</i>	‘without asking’
<i>pī:x-o-ø</i>	‘without going’
<i>po:r-o-ø</i>	‘without coming’
<i>uṇ-o-ø</i>	‘without drinking’
<i>ōšt-o-ø</i>	‘without telling’
<i>kaṛ-o-ø</i>	‘without milking’
<i>par-o-ø</i>	‘without writing’
<i>a:foṛ-o-ø</i>	‘without talking’
<i>kaē-o-ø</i>	‘without learning’
<i>kīyofoy kelc</i>	‘work which is not done’
<i>kaṛofoy īr</i>	‘buffalo which is not milked’
<i>kaṛofoy moj</i>	‘buttermilk which is not churned’
<i>īnofoy twī:ṛ</i>	‘food which is not eaten’
<i>pu:fofoy pu:txuṣy</i>	‘cloak which is not worn’
<i>po:y ilø</i>	‘without having mouth’
<i>mīṣ ilø</i>	‘without having breast’
<i>īr ilø</i>	‘without having buffalo’
<i>po:r-o-en-i</i> (2.53)	—> <i>po:reni</i> ‘I did not come’
<i>po:r-o-īy-i</i> (2.53)	—> <i>po:rīyi</i> ‘he/they did not come’

- wī:ḍ-o en-i* (2.53) —> *wī:ḍeni*  
'I did not run'
- wī:ḍ-o-im-i* (2.53) —> *wī:ḍimi*  
'we (excl.) did not run'
- wī:ḍ-o-um-i* (2.53) —> *wī:ḍumi*  
'we (incl.) did not run'
- wī:ḍ-o-īy-i* (2.53) —> *wī:ḍīyi*  
'They did not run'
- nīl-o-en-i* (2.53) —> *nīleni*  
'I did not stand'
- nīl-o-im-i* (2.53) —> *nīlimi*  
'we (excl.) did not stand'
- nīl-o-um-i* (2.53) —> *nīlumi*  
'we (incl.) did not stand'
- nīl-o-š-i* (2.53) —> *nīlši*  
'you (pl.) did not stand'
- kīy-o-en-i* (2.53) —> *kīyeni*  
'I did not do (work)'
- kīy-o-im-i* (2.53) —> *kīyimi*  
'we (excl.) did not do'
- kīy-o-um-i* (2.53) —> *kīyumi*  
'we (incl.) did not do'
- kīy-o-š-i* (2.53) —> *kīyši*  
'you (pl.) did not do'
- po:r-o-p-i* —> *po:ropi* 'you did not come (sg.)'
- po:r-o-ī-i* —> *po:roti* 'he/she did not come'
- wī:ḍ-o-p-i* —> *wī:ḍopi* 'you did not run (sg.)'



## 4.7. Dubitative

S<sub>1</sub>— Dub -Pron. Sfx- Decl. Sfx.

$$\left\{ \begin{array}{l} -\check{s}- \\ \sim -\check{s}- \end{array} \right\}$$

4.7.1.  $\sim -\check{s}-$  occurs after the verbal base (S<sub>1</sub>)

Ex. <i>nīl-š-pin-i</i>	—>	<i>nīlšpini</i>	‘I may stand’
<i>kīy-š-pin-i</i>	—>	<i>kīyšpini</i>	‘I may do’
<i>tīn-š-pin-i</i>	—>	<i>tīnšpini</i>	‘I may eat’
<i>ūrṣ-š-pin-i</i>	—>	<i>ūrṣšpini</i>	‘I may play (puxury)’
<i>par-š-pin-i</i>	—>	<i>paršpini</i>	‘I may write’
<i>paš-š-pin-i</i> (2.18)	—>	<i>pašpini</i>	‘I may come’
<i>taš-š-pin-i</i> (2.18)	—>	<i>tašpini</i>	‘I may give’

4.8. Voluntative<sup>1</sup>

$$S_1 -k- \left\{ \begin{array}{l} 1 \text{ sg.} \\ 1 \text{ pl.} \end{array} \right\}$$

$$\left\{ \begin{array}{l} -k- \\ \sim -k- \end{array} \right\}$$

4.8.1.  $\sim -k-$

Ex. <i>kīy-k-in</i>	—>	<i>kīykin</i>	‘I will do’
<i>uṇ-k-in</i>	—>	<i>uṇkin</i>	‘I will drink’
<i>nwī.t-k-in</i>	—>	<i>nwī.tkin</i>	‘I will see’
<i>öšt-k-in</i>	—>	<i>öštkin</i>	‘I will say’

<sup>1</sup> A future tense which is usually voluntative.

<i>paš-k-in</i>	—>	<i>paškin</i>	‘I will come’
<i>taš-k-in</i>	—>	<i>taškin</i>	‘I will give’
<i>nīl-k-in</i>	—>	<i>nīlkin</i>	‘I will stand’
<i>tīn-k-in</i>	—>	<i>tīnkin</i>	‘I will eat’
<i>kīy-k-im</i>	—>	<i>kīykim</i>	‘we (excl.) will do’
<i>tīn-k-im</i>	—>	<i>tīnkim</i>	‘we (excl.) will eat’
<i>uṇ-k-im</i>	—>	<i>uṇkim</i>	‘we (excl.) will drink’
<i>nwī:ṭ-k-im</i>	—>	<i>nwī:ṭkim</i>	‘we (excl.) will look’
<i>nīl-k-im</i>	—>	<i>nīlkin</i>	‘we (excl.) will stand’
<i>ōšt-k-um</i>	—>	<i>ōštikum</i>	‘we (incl.) will say’
<i>wī:d-k-um</i>	—>	<i>wī:dikum</i>	‘we (incl.) will run’
<i>nīl-k-um</i>	—>	<i>nīlkuṇ</i>	‘we (incl.) will stand’
<i>nwī:ṭ-k-um</i>	—>	<i>nwī:ṭkuṇ</i>	‘we (incl.) will see’
<i>kīy-k-um</i>	—>	<i>kīykuṇ</i>	‘we (incl.) will do’

#### 4.9. Hortative

$S_1$ —

{ -mo: }  
~ -mo:

4.9.1. ~ -mo: occurs after the verbal base ( $S_1$ ).

Ex. <i>ōšt-mo:</i>	‘let (someone) say’
<i>pint-mo:</i>	‘let (someone) ask’
<i>a:foṭ-mo:</i>	‘let (someone) talk’
<i>kīy-mo:</i>	‘let (someone) do’
<i>tīn-mo:</i>	‘let (someone) eat’
<i>uṇ-mo:</i>	‘let (someone) drink’

<i>nīl-mo:</i>	‘let (someone) stand’
<i>o:ḍ-mo</i>	‘let (someone) dance’
<i>nwī:t-mo:</i>	‘let (someone) see’

4.10. Permissive<sup>1</sup>S<sub>1</sub>-
$$\left\{ \begin{array}{l} -(k)u \\ \sim -(k)u \end{array} \right\}$$
4.10.1.  $\sim -(k)u$  occurs after the verbal base (S<sub>1</sub>).

Ex. <i>kīy-u</i>	
<i>kīy-ku</i>	‘(one) may do’
<i>tīn-u</i>	
<i>tīn-ku</i>	‘(one) may eat’
<i>wī:ḍ-u</i>	
<i>wī:ḍ-ku</i>	‘(one) may run’
<i>par-u</i>	
<i>par-ku</i>	‘(one) may write’
<i>a:foṛ-u</i>	
<i>a:foṛ-ku</i>	‘(one) may talk’
<i>ḍṣt-u</i>	
<i>ḍṣt-ku</i>	‘(one) may say’
<i>nwī:t-u</i>	
<i>nwī:t-ku</i>	‘(one) may see’

1. In Kodagu language, permissive is formed by adding *-u* to the base: in certain places it is preceded by the formative suffix *-k*.

## 4.11. Imperative

## 4.11.1. Singular

S<sub>1</sub>—4.11.1.1. S<sub>1</sub> stem itself functions as the imperative.

Ex. <i>kīy</i>	‘do’
<i>nīl</i>	‘stand’
<i>ke:ʃ</i>	‘hear’
<i>ōšt</i>	‘tell’
<i>wī:d</i>	‘run’
<i>uŋ</i>	‘drink’
<i>tīn</i>	‘eat’

## 4.11.2. Plural

S<sub>1</sub>—

{ -s }

~ -s

4.11.2.1. ~ -s occurs after the verbal base (S<sub>1</sub>).

Ex. <i>nīl-s</i>		‘stand’
<i>tīn-s</i>		‘eat’
<i>ōšt-s</i>		‘tell’
<i>kīy-s</i>	(2.14) —>	<i>kīyš</i> ‘do’
<i>uŋ-s</i>	(2.15) —>	<i>uŋs</i> ‘drink’
<i>wī:d-s</i>	(2.15) —>	<i>wī:dš</i> ‘run’
<i>naŋ-s</i>	(2.15) —>	<i>naŋs</i> ‘walk’

## 4.12. Relative participle

$$\left\{ \begin{array}{l} S_2 \text{ --- Tense} \\ S_1 \text{ --- Neg.} \end{array} \right\} -$$

$$\left\{ \begin{array}{l} -foy \end{array} \right\}$$

$$\infty -\emptyset \quad \infty -foy$$

4.12.1.  $\infty -\emptyset$  occurs after tense suffix  $-t$ . $S_2$ — Tense—

Ex. <i>kaḷ-t-∅</i>	—> <i>kaḷt</i>	‘that is studying’
<i>pod-t-∅</i>	—> <i>podt</i>	‘that is coming’
<i>kīś-t-∅</i>	—> <i>kīśt</i>	‘that is doing’
<i>uḍ-t-∅</i>	—> <i>uḍt</i>	‘that is drinking’
<i>pī:-t-∅</i>	—> <i>pī:t</i>	‘that is going’
<i>tīḍ-t-∅</i>	—> <i>tīḍt</i>	‘that is eating’
<i>pūṣoḍə-t-∅</i>	—> <i>pūṣoḍət</i>	‘that is calling’
<i>mu:neḷ-t-∅</i>	—> <i>mu:neḷt</i>	‘that is liking’
<i>nīḍ-t-∅</i>	—> <i>nīḍt</i>	‘that is standing’
<i>podt mox</i>		‘boy who comes’
<i>pī:t pō:ṛmox</i>		‘Tamil boy who comes’
<i>īr paḷt o:ḷ</i>		‘person who catches buffalo’
<i>kaḷt mox</i>		‘boy who reads’
<i>paṛət ku:x</i>		‘girl who writes’

4.12.2.  $\infty -foy$  occurs after tense suffix  $-t$  and negative suffix  $-o$ . $S_2$ — Tense—

Ex. <i>kaḷ-t(-foy)</i>	—> <i>kaḷfoy</i>	‘studied’
------------------------	------------------	-----------

<i>kīs-θ-foy</i>	—>	<i>kīsfoy</i>	‘done’
<i>naṛə-θ-foy</i>	—>	<i>naṛəfoy</i>	‘walked’
<i>pod-θ-foy</i> *	—>	<i>podfoy</i>	‘came’
<i>ōšty-θ-foy</i> (2.26)	—>	<i>ōštfoy</i>	‘told’
<i>noky-θ-foy</i> (2.26)	—>	<i>nokfoy</i>	‘licked’
<i>karə-θ-foy</i>	—>	<i>karəfoy</i>	‘milked’
<i>kaṛə-θ-foy</i>	—>	<i>kaṛəfoy</i>	‘churned’
<i>wī:ḍy-θ-foy</i> (2.26)	—>	<i>wi:ḍfoy</i>	‘run’
<i>tīḍ-θ-foy</i>	—>	<i>tīḍfoy</i>	‘ate’
<i>kaṛə-θ-foy</i>	—>	<i>kaṛəfoy</i>	‘send’

S<sub>1</sub>— Neg—

Ex. <i>pī:x-o-foy</i>	—>	<i>pī:xofoy</i>	‘not going’
<i>tīn-o-foy</i>	—>	<i>tīnofoy</i>	‘not eating’
<i>nwī:t-o-foy</i>	—>	<i>nwī:tfofoy</i>	‘not seeing’
<i>uṇ-o-fov</i>	—>	<i>uṇofoy</i>	‘not drinking’
<i>kaḷ-o-foy</i>	—>	<i>kaḷofoy</i>	‘not studying’
<i>kar-o-foy</i>	—>	<i>karofoy</i>	‘not milking’
<i>kīv-o-foy</i>	—>	<i>kīyofoy</i>	‘not doing’
<i>po:r-o-foy</i>	—>	<i>po:rofoy</i>	‘not coming’
<i>podfoy ma:f</i>			‘Badaga who came’
<i>kīsfoy kelc</i>			‘work which was done’
<i>kaṛəfoy īr</i>			‘buffalo which was milked’
<i>kīyofoy kelc</i>			‘work which was not done’
<i>pī:xofoy o:ḷ</i>			‘person who did not go’

<i>po:rofoy ars</i>	‘English man who did not come’
<i>(poŋm) pīntofoy o:č</i>	‘person who did not ask (money)’

## 4.13. Verbal participle

$$\left\{ \begin{array}{l} S_2\text{-Past} \\ S_1\text{-Neg.} \end{array} \right\} -$$

$$\left\{ -\emptyset \right\}$$

$$\infty -\emptyset \infty -\emptyset$$
4.13.1.  $\infty -\emptyset$  occurs after negative suffix  $-o$ .
 $S_1\text{-Neg}$ 

Ex. <i>kīy-o-∅</i>	→ <i>kīy∅</i>	‘without doing’
<i>pīnt-o-∅</i>	→ <i>pīnt∅</i>	‘without asking’
<i>kar-o-∅</i>	→ <i>kar∅</i>	‘without milking’
<i>tīn-o-∅</i>	→ <i>tīn∅</i>	‘without eating’
<i>uŋ-o-∅</i>	→ <i>uŋ∅</i>	‘without drinking’
<i>ōšt-o-∅</i>	→ <i>ōšt∅</i>	‘without saying’
<i>nwī:t-o-∅</i>	→ <i>nwī:t∅</i>	‘without seeing’
<i>nīl-o-∅</i>	→ <i>nīl∅</i>	‘without standing’
<i>pūšod-o-∅</i>	→ <i>pūšod∅</i>	‘without calling’
<i>pax-o-∅</i>	→ <i>pax∅</i>	‘without dividing’
<i>kwīr-o-∅</i>	→ <i>kwīr∅</i>	‘without giving’

4.13.2.  $\infty -\emptyset$  occurs elsewhere.
 $S_2\text{-Past-}$ 

Ex. *pod-s-∅* (2.42,49) → *poz* ‘having come’

<i>kaṛθ-s-θ</i>	(2.41)	—>	<i>kaṛs</i>	‘having milked’
<i>kaṛθ-s-θ</i>	(2.41)	—>	<i>kaṛs</i>	‘having churned’
<i>koḍ-s-θ</i>	(2.48,49)	—>	<i>koḥ</i>	‘having seen’
<i>puk-s-θ</i>	(2.47)	—>	<i>pukṣ</i>	‘having entered’
<i>kwīṛt-s-θ</i>	(2.41)	—>	<i>kwīṛs</i>	‘having given’
<i>aṭθ-s-θ</i>	(2.41)	—>	<i>aṭs</i>	‘having measured’
<i>tīḍ-s-θ</i>	(2.44,49)	—>	<i>tīḥ</i>	‘having eaten’
<i>uḍ-s-θ</i>	(2.48,49)	—>	<i>uḥ</i>	‘having drunk’
<i>toḍ-s-θ</i>	(2.42,49)	—>	<i>toḥ</i>	‘having given’
<i>nīḍ-s-θ</i>	(2.44,49)	—>	<i>nīḥ</i>	‘having stood’
<i>te:ḍ-s-θ</i>	(2.44,49)	—>	<i>te:ḥ</i>	‘having done’
<i>nī:ḍ-s-θ</i>	(2.48,49)	—>	<i>nī:ḥ</i>	‘having peeped’
<i>kīḍy-s-θ</i>	(2.26,46,49)	—>	<i>kīḥ</i>	‘having sprinkled’
<i>teṛθ-s-θ</i>	(2.41)	—>	<i>teṛs</i>	‘having opened’

## 4.14. Participial noun

{	S <sub>2</sub> -	{	Pres. tense	}	}	-
		{	Past tense	}		
{	S <sub>1</sub> -	-	Neg.	-	}	
		{	-θ-	}		
	∞	-θ-	∞	-foy		

## 4.14.1. ∞ -θ occurs after tense suffix -p and before o:ṭ

Ex. <i>pod-p-θ-o:ṭ</i>	—>	<i>podpo:ṭ</i>	‘person who comes’
<i>kīs-p-θ-o:ṭ</i>	—>	<i>kīspoṭ</i>	‘person who does’
<i>pi:-p-θ-o:ṭ</i>	—>	<i>pi:po:ṭ</i>	‘person who goes’

<i>mo:ry-p-θ-o:ʃ</i>	→	<i>mo:rypo:ʃ</i>	‘seller or person who sells’
<i>ud-p-θ-o:ʃ</i>	→	<i>udpo:ʃ</i>	‘person who drinks’
<i>tīd-p-θ-o:ʃ</i>	→	<i>tīdpo:ʃ</i>	‘person who eats’
<i>paŋy-p-θ-o:ʃ</i>	→	<i>paŋypo:ʃ</i>	‘person who catches (buffalo)’
<i>karθ-p-θ-o:ʃ</i>	→	<i>karθpo:ʃ</i>	‘person who milks’
<i>karθ-p-θ-o:ʃ</i>	→	<i>karθpo:ʃ</i>	‘person who churns’
<i>öšty-p-θ-o:ʃ</i>	→	<i>öštypo:ʃ</i>	‘person who says’

4.14.2. ∞-foy occurs after tense suffix -θ, negative -o- and before -o:ʃ.

Ex. <i>pod-θ-foy-o:ʃ</i>	→	<i>podfoyo:ʃ</i>	‘person who came’
<i>kīs-θ-foy-o:ʃ</i>	→	<i>kīsfoyo:ʃ</i>	‘person who did (work)’
<i>öšty-θ-foy-o:ʃ</i> (2.26)	→	<i>öštfoyo:ʃ</i>	‘person who said’
<i>ud-θ-foy-o:ʃ</i>	→	<i>udfoyo:ʃ</i>	‘person who drank’
<i>wī:dŋ-θ-foy-ø:ʃ</i>	→	<i>wī:dŋfoyo:ʃ</i>	‘person who ran’
<i>a:foŋ-θ-foy-o:ʃ</i>	→	<i>a:foŋfoyo:ʃ</i>	‘person who takled’
<i>e:mo:ty-θ-foy-o:ʃ</i> (2.26)	→	<i>e:mo:tfoyo:ʃ</i>	‘person who deceived’
<i>nađty-θ-foy-o:ʃ</i> (2.26)	→	<i>nađtfoyo:ʃ</i>	‘person who conducted’

<i>nwī:ɬ-o-foy-o:ʔ</i>	—>	<i>nwī:ɬofoyo:ʔ</i>	‘person who did not see’
<i>pī:x-o-foy-o:ʔ</i>	—>	<i>pī:xofoyo:ʔ</i>	‘person who did not go’
<i>uŋ-o-foy-o:ʔ</i>	—>	<i>uŋofoyo:ʔ</i>	‘person who did not drink’
<i>kīy-o-foy-o:ʔ</i>	—>	<i>kīyofoyo:ʔ</i>	‘person who did not do’
<i>kaʔ-o-foy-o:ʔ</i>	—>	<i>kaʔofoyo:ʔ</i>	‘person who did not read’

## 4.15. Temporal

{ S <sub>2</sub> -tense }	}	-
{ S <sub>1</sub> -Neg. }		
{ -fok }		
~ -fok		

4.15.1. ~ -fok occurs after tense marker -ø and after negative suffix -o.

Ex. <i>pod-ø-fok</i>	—>	<i>podfok</i>	‘while coming’
<i>nwī:ty-ø-fok</i> (2.26)	—>	<i>nwī:tfok</i>	‘while seeing’
<i>wī:dy-ø-fok</i> (2.26)	—>	<i>wī:dfok</i>	‘while running’
<i>kīs-ø-fok</i>	—>	<i>kīsfok</i>	‘while doing’
<i>pi:-ø-fok</i>	—>	<i>pi:fok</i>	‘while going’
<i>a:fot-ø-fok</i>	—>	<i>a:fotfok</i>	‘while talking’
<i>kwīɾt-ø-fok</i>	—>	<i>kwīɾtfok</i>	‘while giving’
<i>pare-ø-fok</i>	—>	<i>parefok</i>	‘while writing’

<i>ka!-θ-fok</i>	—>	<i>ka!fok</i>	‘while learning’
<i>tīd-θ-fok</i>	—>	<i>tīdfok</i>	‘while eating’
<i>uđ-θ-fok</i>	—>	<i>uđfok</i>	‘while drinking’
<i>nīd-θ-fok</i>	—>	<i>nīdfok</i>	‘while standing’
<i>kīy-o-fok</i>	—>	<i>kīyofok</i>	‘while not doing’
<i>kaṛ-o-fok</i>	—>	<i>kaṛfok</i>	‘while not milking’
<i>tīn-o-fok</i>	—>	<i>tīnofok</i>	‘while not eating’
<i>uṇ-o-fok</i>	—>	<i>uṇofok</i>	‘while not drinking’
<i>pī:x-o-fok</i>	—>	<i>pī:xofok</i>	‘while not going’
<i>po:r-o-fok</i>	—>	<i>po:rofok</i>	‘while not coming’
<i>netyš ko:s itfok</i>			‘while keeping coins on forehead’
<i>pīšu:tifok</i>			‘while turning earth at funeral’
<i>īrpa!fok</i>			‘while catching the buffalo’

## 4.16. Verbal noun

S<sub>2</sub>— tense— aux—

{ -t }

~ -t

4.16.1. ~ -t occurs after auxiliary verb *-fīd*.

Ex. <i>pod-θ-fīd-t</i>	—>	<i>podfīdt</i>	‘the act of coming’
<i>pī:-θ-fīd-t</i>	—>	<i>pī:fīdt</i>	‘the act of going’
<i>öšty-θ-fīd-t</i> (2.26)	—>	<i>öštfīdt</i>	‘the act of saying’
<i>kīs-θ-fīd-t</i>	—>	<i>kīsfīdt</i>	‘the act of doing’
<i>nwī:ty-θ-fīd-t</i> (2.26)	—>	<i>nwī:tīfīdt</i>	‘the act of seeing’
<i>uđ-θ-fīd-t</i>	—>	<i>uđfīdt</i>	‘the act of drinking’

- pinty-θ-fīd-t* (2.26) → *pintfīdt*  
 'the act of asking'
- naṛθ-θ-fīd-t* → *naṛəfīdt* 'the act of walking'
- ay o:ṛ i:nk podfīdt sariyilīyi*  
 'His coming here is not good'
- ni: am modk p?:fīdt walīyi*  
 'your going to that mund is not good'

4.17. Negative<sub>2</sub>

Present-future negative<sup>1</sup> & 2

S<sub>2</sub>— aux—

{ -o- }

~ -o-

## 4.17.1. ~ -o-

- Ex. *pod-kīṣ-o-en-i* (2.53) → *podkīṣeni*  
 'I will not come'
- pod-kīṣ-o-īy-i* (2.53) → *podkīṣīyi*  
 'He will not come'

- 
1. In present-future negative finite verbs, *kīṣ* 'be able' (S<sub>1</sub>) is added to S<sub>2</sub> forms of verb.
  2. In Toda both 'I will not come', 'I will not be able to come' are expressed by one and the same form *podkīṣeni*. In certain circumstances, *enna:l po:ka muṭiya:tu* 'I will not be able to go' is also used just denote 'I will not go'. Professor. S. Agesthalingom has dealt with future in Tamil in his paper entitled "Modality in Tamil",

—S. Agesthalingom, "Modality in Tamil"

Second All India Conference of Linguists, Delhi-1971

- pi-kīś-o-īy-i* (2.53) → *pi:kīśīyi*  
'He will not go'
- tīd-kīś-o-en-i* (2.53) → *tīdkīśeni*  
'I will not eat'
- tīd-kīś-o-īy-i* (2.53) → *tīdkīśīyi*  
'He will not eat'
- uḍ-kīś-o-en-i* (2.53) → *uḍkīśeni*  
'I will not drink'
- uḍ-kīś-o-īy-i* (2.53) → *uḍkīśīyi*  
'He will not drink'
- ōšty-kīś-o-en-i* (2.26,53) → *ōštīkīśīyi*  
'I will not say'
- ōšty-kīś-o-īy-i* (2.26,53) → *ōštīkīśēī*  
'He will not say'
- nwī:ty-kīś-o-en-i* (2.26,53) → *nwī:tkīśeni*  
'I will not see'
- nwī:ty-kīś-o-īy-i* (2.26,53) → *nwī:tkīśīyi*  
'He will not see'
- pod-kīś-o-p-i* → *podkīśopi* 'you will not come'
- tīd-kīś-o-p-i* → *tīdkīśopi* 'you will not eat'
- pī-kīś-o-p-i* → *pī:kīśopi* 'you will not go'
- uḍ-kīś-o-p-i* → *uḍkīśopi* 'you will not drink'
- ōšty-kīś-o-p-i* (2.26) → *ōštīkīśopi*  
'you will not say'
- nwī:ty-kīś-o-p-i* (2.26) → *nwī:tkīśopi*  
'you will not see'

## 4.18. Personal suffixes

{ S<sub>2</sub>— Tense } —  
{ S<sub>1</sub>— Neg. } —

4.18.1. *First person singular*

$$\{ -pin- \}$$

$$\infty -pin \quad \infty -pen \quad \infty -n \quad \infty -in \quad \infty -en$$

4.18.1.1.  $\infty -pin-$  occurs after present tense and past tense suffixes in declaratives.

Ex. <i>pod-<math>\emptyset</math>-pin-i<sup>1</sup></i>	$\rightarrow$	<i>podpini</i>	'come-I'
<i>tī<math>\underline{d}</math>-<math>\emptyset</math>-pin-i</i>	$\rightarrow$	<i>tī<math>\underline{d}</math>pini</i>	'eat-I'
<i>ko<math>\underline{d}</math>-<math>\emptyset</math>-pin-i</i>	$\rightarrow$	<i>ko<math>\underline{d}</math>pini</i>	'look-I'
<i>kī<math>\underline{d}</math>-<math>\emptyset</math>-pin-i</i>	$\rightarrow$	<i>kī<math>\underline{d}</math>pini</i>	'sprinkle-I'
<i>ka<math>\underline{r}</math><math>\emptyset</math>-<math>\emptyset</math>-pin-i</i>	$\rightarrow$	<i>ka<math>\underline{r}</math><math>\emptyset</math>pini</i>	'milk-I'
<i>te:<math>\underline{d}</math>-<math>\emptyset</math>-pin-i</i>	$\rightarrow$	<i>te:<math>\underline{d}</math>pini</i>	'do (work)-I'
<i>sö:<math>\underline{d}</math>-<math>\emptyset</math>-pin-i</i>	$\rightarrow$	<i>sö:<math>\underline{d}</math>pini</i>	'arrive-I'
<i>ud-<math>\emptyset</math>-pin-i</i>	$\rightarrow$	<i>udpini</i>	'smear-I'
<i>ni:<math>\underline{d}</math>-<math>\emptyset</math>-pin-i</i>	$\rightarrow$	<i>ni:<math>\underline{d}</math>pini</i>	'peep over-I'
<i>pod-s-pin-i</i> (2.42,49)	$\rightarrow$	<i>pozpini</i>	'came-I'
<i>tī<math>\underline{d}</math>-s-pin-i</i> (2.44,49)	$\rightarrow$	<i>tī<math>\underline{z}</math>pini</i>	'ate-I'
<i>ko<math>\underline{d}</math>-s-pin-i</i> (2.48,49)	$\rightarrow$	<i>ko<math>\underline{z}</math>pini</i>	'looked-I'
<i>kī<math>\underline{d}</math>y-s-pin-i</i> (2.26,46,49)	$\rightarrow$	<i>kī<math>\underline{z}</math>pini</i>	'sprinkled-I'
<i>ka<math>\underline{r}</math><math>\emptyset</math>-s-pin-i</i> (2.41)	$\rightarrow$	<i>ka<math>\underline{r}</math><math>\underline{s}</math>pini</i>	'milked-I,
<i>te:<math>\underline{d}</math>-s-pin-i</i> (2.44,49)	$\rightarrow$	<i>te:<math>\underline{z}</math>pini</i>	'did (work)-I'
<i>sö:<math>\underline{d}</math>-s-pin-i</i> (2.42,49)	$\rightarrow$	<i>sö:<math>\underline{z}</math>pini</i>	'arrived-I'
<i>ud-s-pin-i</i> (2.42,49)	$\rightarrow$	<i>uzpini</i>	'smeared-I'
<i>nī:<math>\underline{d}</math>-s-pin-i</i> (2.48,49)	$\rightarrow$	<i>nī:<math>\underline{z}</math>pini</i>	'peeped over-I'

i. *i* is segmented as declarative suffix.

<i>uḍ-s-pin-i</i>	(2.48,49)	—>	<i>uzḗpini</i>	‘drank-I’
<i>naṛø-s-pin-i</i>	(2.41)	—>	<i>naṛspini</i>	‘walked-I’
<i>mu:neṭ-s-pin-i</i>	(2.43,49)	—>	<i>mu:nespini</i>	‘liked-I’

4 18 1 2.  $\infty$ -pen occurs after tense marker when it is followed by interrogative.

Ex. <i>pi:-ø-pen</i>	—>	<i>pi:pen</i>	‘go-I’	
<i>pod-ø-pen</i>	—>	<i>podpen</i>	‘come-I’	
<i>tīḍ-ø-pen</i>	—>	<i>tīḍpen</i>	‘eat-I’	
<i>uḍ-ø-pen</i>	—>	<i>uḍpen</i>	‘drink-I’	
<i>kīṣ-ø-pen</i>	—>	<i>kīṣpen</i>	‘do-I’	
<i>nwī:ṭ-ø-pen</i>	—>	<i>nwī:ṭpen</i>	‘look-I’	
<i>kaṛø-ø-pen</i>	—>	<i>kaṛøpen</i>	‘milk-I’	
<i>püṣoḍø-ø-pen</i>	—>	<i>püṣoḍøpen</i>	‘call-I’	
<i>naṛø-ø-pen</i>	—>	<i>naṛøpen</i>	‘walk-I’	
<i>pod-s-pen</i>	(2.42,49)	—>	<i>pozpen</i>	‘came-I’
<i>tīḍ-s-pen</i>	(2.44,49)	—>	<i>tīḗpen</i>	‘ate-I’
<i>uḍ-s-pen</i>	(2.48,49)	—>	<i>ıḗpen</i>	‘drank-I’
<i>nwī:ty-s-pen</i>	(2.26,47,49)	—>	<i>nwī:ṣpen</i>	‘looked-I’
<i>kaṛø-s-pen</i>	(2.41)	—>	<i>kaṛspen</i>	‘milked-I’
<i>püṣoḍø-s-pen</i>	(2.41)	—>	<i>püṣoḍspen</i>	‘called-I’
<i>naṛø-s-pen</i>	(2.41)	—>	<i>naṛspen</i>	‘walked-I’

4.18.1.3.  $\infty$  -n occurs after tense marker when it is preceded by interrogative

Ex. <i>pi:-θ-n</i>	—>	<i>pi:n</i>	‘go-I’
<i>pod-θ-n</i>	—>	<i>podn</i>	‘come-I’
<i>tīd-θ-n</i>	—>	<i>tīdn</i>	‘eat-I’
<i>uđ-θ-n</i> (2.17)	—>	<i>uđn</i>	‘drink-I’
<i>o:d-θ-n</i> (2.17)	—>	<i>o:dñ</i>	‘dance-I’
<i>nwī:ty-θ-n</i>	—>	<i>nwī:tyñ</i>	‘look-I’
<i>karθ-θ-n</i>	—>	<i>karθñ</i>	‘milk-I’
<i>püşođθ-θ-n</i>	—>	<i>püşođθñ</i>	‘call-I’
<i>nařθ-θ-n</i>	—>	<i>nařθñ</i>	‘walk-I’
<i>pi:-s-n</i> (2.45)	—>	<i>pi:šñ</i>	‘went-I’
<i>pod-s-n</i> (2.42,49)	—>	<i>pozñ</i>	‘came-I’
<i>tīd-s-n</i> (2.44,49)	—>	<i>tīzñ</i>	‘ate-I’
<i>uđ-s-n</i> (2.48,49,17)	—>	<i>uzñ</i>	‘drank-I’
<i>o:d-s-n</i> (2.48,49,17)	—>	<i>o:zñ</i>	‘danced-I’
<i>nwī:ty-s-n</i> (2.26,47,49,17)	—>	<i>nwī:šñ</i>	‘looked-I’
<i>karθ-s-n</i> (2.41)	—>	<i>kařsn</i>	‘milked-I’
<i>püşođθ-s-n</i> (2.41)	—>	<i>püşođsn</i>	‘called-I’
<i>nařθ-s-n</i> (2.41)	—>	<i>nařsn</i>	‘walked-I’

4.18.1.4.  $\infty$  -in occurs after voluntative suffix -k.

Ex. <i>kīy-k-in</i>	—>	<i>kīykin</i>	‘I will do’
<i>tīn-k-in</i>	—>	<i>tīnkin</i>	‘I will eat’
<i>nīl k-in</i>	—>	<i>nīlkin</i>	‘I will stand’
<i>paš-k-in</i>	—>	<i>paškin</i>	‘I will come’
<i>taš-k-in</i>	—>	<i>taškin</i>	‘I will give’

<i>uṅ-k-in</i>	—>	<i>uṅkin</i>	'I will drink'
<i>nwī:ṭ-k-in</i>	—>	<i>nwī:ṭkin</i>	'I will see'
<i>ōšt-k-in</i>	—>	<i>ōštkin</i>	'I will say'
<i>kwīṛ-k-in</i>	—>	<i>kwīṛkin</i>	'I will give'
<i>ürp-k-in</i>	—>	<i>ürpkin</i>	'I will play (puxury)'
<i>pī:x-k-in</i>	—>	<i>pī:xkin</i>	'I will go'
<i>teṛ-k-in</i>	—>	<i>teṛkin</i>	'I will open'

4.18.1.5.  $\infty$  *en-* occurs (1) after tense and before conditional suffix *-wīṛ* and (2) after the negative and before declarative suffix *-i*.

Ex. <i>pod-ḡ-en-wīṛ</i>	—>	<i>podenwīṛ</i>	'If I come'
<i>pī:-ḡ-en-wīṛ</i>	—>	<i>pi:enwīṛ</i>	'If I go'
<i>naṛḡ-ḡ-en-wīṛ</i>	—>	<i>naṛḡenwīṛ</i>	'If I walk'
<i>kīs-ḡ-en-wīṛ</i>	—>	<i>kīsenwīṛ</i>	'If I do'
<i>po:r-o-en-i</i>	(2.53)	<i>po:reni</i>	'I did not come'
<i>pī:x-o-en-i</i>	(2.53)	<i>pī:xeni</i>	'I did not go'
<i>tīn-o-en-i</i>	(2.53)	<i>tīneni</i>	'I did not eat'
<i>uṅ-o-en-i</i>	(2.53)	<i>uṅeni</i>	'I did not drink'
<i>kīy-o-en-i</i>	(2.53)	<i>kīyeni</i>	'I did not go'
<i>nīl-o-en-i</i>	(2.53)	<i>nīleni</i>	'I did not stand'

<i>kaṭ-o-en-i</i>	(2 53)	—>	<i>kaṭeni</i> 'I did not read'
<i>öšt-o-en-i</i>	(2 53)	—>	<i>öšteni</i> 'I did not say'
<i>pint-o-en-i</i>	(2 53)	—>	<i>pinteni</i> 'I did not ask'
<i>podkīṣ-o-en-i</i>	(2.53)	—>	<i>podkīṣeni</i> 'I will not come'
<i>pi:kīṣ-o-en-i</i>	(2.53)	—>	<i>pi:kīṣeni</i> 'I will not go'
<i>tīḍkīṣ-o-en-i</i>	(2 53)	—>	<i>tīḍkīṣeni</i> 'I will not eat'
<i>uḍkīṣ-o-en-i</i>	(2 53)	—>	<i>uḍkīṣeni</i> 'I will not drink'
<i>öšt kīṣ-o-en-i</i>	(2 53)	—>	<i>öšt kīṣeni</i> 'I will not say'
<i>wī:ḍkīṣ-o-en-i</i>	(2.53)	—>	<i>wī:ḍkīṣeni</i> 'I will not run'
<i>parəkīṣ-o-en-i</i>	(2.53)	—>	<i>parəkīṣeni</i> 'I will not write'
<i>nīḍkīṣ-o-en-i</i>	(2.53)	—>	<i>nīḍkīṣeni</i> 'I will not stand'

First person plural (excl.)

{ -pim- }

∞ -pim    ∞ -pem    ∞ -m    ∞ im    ∞ -em

4 18.1.6.  $\infty$  -*pim*- occurs after the tense in declarative.

Ex. <i>tīd-∅-pim-i</i>	—>	<i>tīd̄pimi</i>	‘eat-we (excl.)’
<i>pīt-∅-pim-i</i>	—>	<i>pīt̄pimi</i>	‘carry-we (excl.)’
<i>koḍ-∅-pim-i</i>	—>	<i>koḍpimi</i>	‘look-we (excl.)’
<i>twa:nt-∅-pim-i</i>	—>	<i>twa:nt̄pimi</i>	‘sweep-we (excl.)’
<i>nīd-∅-pim-i</i>	—>	<i>nīd̄pimi</i>	‘stand-we (excl.)’
<i>pi:-∅-pim-i</i>	—>	<i>pi:pimi</i>	‘go-we (excl.)’
<i>uḍ-∅-pim-i</i>	—>	<i>uḍ̄pimi</i>	‘drink-we (excl.)’
<i>pod-∅-pim-i</i>	—>	<i>pod̄pimi</i>	‘come-we (excl.)’
<i>tīd-s-pim-i</i>	(2.44,49)	—>	<i>tīz̄pimi</i> ‘ate-we (excl.)’
<i>pod-s-pim-i</i>	(2.42,49)	—>	<i>poz̄pimi</i> ‘came-we (excl.)’
<i>koḍ-s-pim-i</i>	(2.48,49)	—>	<i>koz̄pimi</i> ‘looked-we (excl.)’
<i>uḍ-s-pim-i</i>	(2.48,49)	—>	<i>uz̄pimi</i> ‘drank-we (excl.)’
<i>nīd-s-pīm-i</i>	(2.44,49)	-->	<i>nīz̄pimi</i> ‘stood-we (excl.)’

4 18 1.7.  $\infty$  -*pem* occurs after tense when it is followed by interrogative.

Ex <i>pi:-∅-pem</i>	—>	<i>pi:pem</i>	‘go-we’
<i>pod-∅-pem</i>	—>	<i>pod̄pem</i>	‘come-we’
<i>tīd-∅-pem</i>	—>	<i>tīd̄pem</i>	‘eat-we’
<i>uḍ-∅-pem</i>	—>	<i>uḍ̄pem</i>	‘drink-we’
<i>nwī:∅-pem</i>	—>	<i>nwī:ṭpem</i>	‘look-we’

<i>o:d-θ-pem</i>	—>	<i>o:dpem</i>	‘dance-we’
<i>ōšt-θ-pem</i>	—>	<i>ōštpem</i>	‘say-we’
<i>pod-s-pem</i>	(2.42,49)	—>	<i>pozpem</i> ‘came-we’
<i>tīd-s-pem</i>	(2.44,49)	—>	<i>tīzpem</i> ‘ate-we’
<i>uḍ-s-pem</i>	(2.48,49)	—>	<i>uzpem</i> ‘drank-we’
<i>nwī:ty-s-pem</i>	(2.26,47,49)	—>	<i>nwī:špem</i> ‘looked-we’

4.18.1.8. ∞ -*m* occurs after tense marker when it is preceded by interrogative

Ex. <i>pi:-θ-m</i>	—>	<i>pi:m</i>	‘go-we’
<i>pod-θ-m</i>	—>	<i>podm</i>	‘come-we’
<i>tīd-θ-m</i>	—>	<i>tīdm</i>	‘eat-we’
<i>uḍ-θ-m</i>	—>	<i>uḍm</i>	‘drink-we’
<i>nwī:t-θ-m</i>	—>	<i>nwī:tm</i>	‘look-we’
<i>pod-s-m</i>	(2.42,49)	—>	<i>poz m</i> ‘came-we’
<i>tīd-s-m</i>	(2.44,49)	—>	<i>tīz m</i> ‘ate-we’
<i>uḍ-s-m</i>	(2.48,49)	—>	<i>uz m</i> ‘drank-we’
<i>nwī:ty-s-m</i>	(2.26,47,49)	—>	<i>nwī:š m</i> ‘looked-we’

4.18.1.9. ∞ -*im* occurs after voluntative suffix -*k*.

Ex. <i>kīy-k-im</i>	—>	<i>kīykim</i>	‘we will do (excl.)’
<i>ōšt-k-im</i>	—>	<i>ōštkim</i>	‘we will say (excl.)’
<i>nwī:t-k-im</i>	—>	<i>nwī:tkim</i>	‘we will look (excl.)’
<i>paš-k-im</i>	—>	<i>paškim</i>	‘we will come (excl.)’

<i>taš-k-im</i>	—>	<i>taškim</i>	‘we will give (excl.)’
<i>naṛ-k-im</i>	—>	<i>naṛkim</i>	‘we will walk(excl.)’
<i>uṇ-k-im</i>	—>	<i>uṇkim</i>	‘we will drink (excl.)’
<i>aṭ-k-in</i>	—>	<i>aṭkim</i>	‘we will measure (excl.)’

4.18.1.10.  $\infty$  -em- occurs after tense when it is followed the conditional marker and it also occurs after the negative and before declarative suffix -i

Ex. <i>pod-θ-em-wīṛ</i>	—>	<i>podeṇwīṛ</i>	‘if we come’
<i>pi-θ-em-wīṛ</i>	—>	<i>pi:emwīṛ</i>	‘if we go’
<i>naṛθ-θ-em-wīṛ</i>	—>	<i>naṛθemwīṛ</i>	‘if we walk’
<i>pī:x-o-em-i</i>	(2.53)	—>	<i>pī:xemi</i> ‘we did not go’
<i>tīn-o-em-i</i>	(2.53)	—>	<i>tīnemi</i> ‘we did not eat’
<i>uṇ-o-em-i</i>	(2.53)	—>	<i>uṇemi</i> ‘we did not drink’
<i>kīy-o-em-i</i>	(2.53)	—>	<i>kīyemi</i> ‘we did not do’
<i>nīl-o-em-i</i>	(2.53)	—>	<i>nīlemi</i> ‘we did not stand’
<i>paṛ-o-em-i</i>	(2.53)	—>	<i>paremi</i> ‘we did not write’
<i>kaṭ-o-em-i</i>	(2.53)	—>	<i>kaṭemi</i> ‘we did not learn’
<i>naṛ-o-em-i</i>	(2.53)	—>	<i>naṛemi</i> ‘we did not walk’
<i>kwīṛ-o-em-i</i>	(2.53)	—>	<i>kwīṛemi</i> ‘we did not give’

<i>podkīṣ-o-em-i</i>	(2.53)	—>	<i>podkīṣemi</i>	‘we will not come’
<i>tīdkīṣ-o-em-i</i>	(2.53)	—>	<i>tīdkīṣemi</i>	‘we will not eat’
<i>uḍkīṣ-o-em-i</i>	(2.53)	—>	<i>uḍkīṣemi</i>	‘we will not drink’
<i>nīdkīṣ-o-em-i</i>	(2.53)	—>	<i>nīdkīṣemi</i>	‘we will not stand’
<i>pi:kīṣ-o-em-i</i>	(2.53)	—>	<i>pi:kīṣemi</i>	‘we will not go’
<i>ōṣtkīṣ-o-em-i</i>	(2.53)	—>	<i>ōṣtkīṣemi</i>	‘we will not say’
<i>wī:dkīṣ-o-em-i</i>	(2.53)	—>	<i>wī:dkīṣemi</i>	‘we will not run’

*First person plural (incl.)*

{ -pum- }

∞-pum- ∞-m ∞-um

4.18.1.11 ∞-pum- occurs after tense in declaratives and also occurs after tense when it is followed by interrogative.

Ex. <i>tīd-∅-pum-i</i>	—>	<i>tīdpumi</i>	‘eat-we (incl.)’
<i>pīt-∅-pum-i</i>	—>	<i>pītpumi</i>	‘sow (seed)-we (incl.)’
<i>koḍ-∅-pum-i</i>	—>	<i>koḍpumi</i>	‘look-we (incl.)’
<i>nīd-∅-pum-i</i>	—>	<i>nīdpumi</i>	‘stand-we (incl.)’
<i>pod-∅-pum-i</i>	—>	<i>podpumi</i>	‘come-we (incl.)’
<i>naṛe-∅-pum-i</i>	—>	<i>naṛepumi</i>	‘walk-we (incl.)’

<i>aʒθ-θ-pum-i</i>	—>	<i>aʒθpumi</i>	‘measure—we (incl.)’
<i>kwīrt-θ-pum-i</i>	—>	<i>kwīrtpumi</i>	‘give—we’
<i>kaɿ-θ-pum-i</i>	—>	<i>kaɿpumi</i>	‘learn—we’
<i>pi:-θ-pum-i</i>	—>	<i>pi:pumi</i>	‘go—we’
<i>tīd-s-pum-i</i> (2.44,49)	—>	<i>tīz̄pumi</i>	‘ate—we’
<i>koɖ-s-pum-i</i> (2.48,49)	—>	<i>koz̄pumi</i>	‘looked—we’
<i>nīd-s-pum-i</i> (2.44,49)	—>	<i>niz̄pumi</i>	‘stood—we’
<i>poɖ-s-pum-i</i> (2.42,49)	—>	<i>poz̄pumi</i>	‘came—we’
<i>naʀθ-s-pum-i</i> (2.41)	—>	<i>naʀspumi</i>	‘walked—we’
<i>kwīrt-s-pum-i</i> (2.41)	—>	<i>kwīrtspumi</i>	‘gave—we’
<i>pi:-θ-pum</i>	—>	<i>pi:pum</i>	‘go—we’
<i>poɖ-θ-pum</i>	—>	<i>poɖpum</i>	‘come—we’
<i>tīd-θ-pum</i>	—>	<i>tīd̄pum</i>	‘eat—we’
<i>uɖ-θ-pum</i>	—>	<i>uɖpum</i>	‘drink—we’
<i>nwī:t-θ-pum</i>	—>	<i>nwī:tpum</i>	‘look—we’
<i>poɖ-s-pum</i> (2.42,49)	—>	<i>poz̄pum</i>	‘came—we’
<i>tīd-s-pum</i> (2.44,49)	—>	<i>tīz̄pum</i>	‘ate—we’
<i>uɖ-s-pum</i> (2.48,49)	—>	<i>uz̄pum</i>	‘drank—we’
<i>nwī:ty-s-pum</i> (2.26,47,49)	—>	<i>nwī:spum</i>	‘looked—we’

4.18.1.12.  $\infty$  -*m* occurs after tense when 'it is preceded by interrogative.

Ex. <i>pi</i> :- $\emptyset$ - <i>m</i>	—>	<i>pi:m</i>	'go-we'
<i>pod</i> - $\emptyset$ - <i>m</i>	—>	<i>podm</i>	'come-we'
<i>tīd</i> - $\emptyset$ - <i>m</i>	—>	<i>tīdm</i>	'eat-we'
<i>uḍ</i> - $\emptyset$ - <i>m</i>	—>	<i>uḍm</i>	'drink-we'
<i>nwī:ty</i> - $\emptyset$ - <i>m</i>	—>	<i>nwī:tym</i>	'look-we'
<i>kaṛə</i> - $\emptyset$ - <i>m</i>	—>	<i>kaṛəm</i>	'milk-we'
<i>püşoḍə</i> - $\emptyset$ - <i>m</i>	—>	<i>püşoḍəm</i>	'call-we'
<i>pod</i> - <i>s</i> - <i>m</i>	(2.42,49)	—>	<i>pozsm</i> 'came-we'
<i>tīd</i> - <i>s</i> - <i>m</i>	(2.44,49)	—>	<i>tīzsm</i> 'ate-we'
<i>uḍ</i> - <i>s</i> - <i>m</i>	(2.48,49)	—>	<i>uzsm</i> 'drank-we'
<i>nwī:ty</i> - <i>s</i> - <i>m</i>	(2.26,47,49)	—>	<i>nwī:šsm</i> 'looked-we'
<i>kaṛə</i> - <i>s</i> - <i>m</i>	(2.41)	—>	<i>kaṛsm</i> 'milked-we'
<i>püşoḍə</i> - <i>s</i> - <i>m</i>	(2.41)	—>	<i>püşoḍsm</i> 'called-we'

4.18.1.13.  $\infty$  -*um*- occurs after present-future and past negative marker and occurs after voluntative suffix -*k* and also occurs after tense suffix when it is followed by conditional marker -*wīṛ*.

Ex. *podkīš-o-um-i* (2.53) —> *podkīšumi*  
'we will not come'

<i>tīdkīṣ-o-um-i</i>	(2.53) —>	<i>tīdkīṣumi</i>	'we will not eat'
<i>uḍkīṣ-o-um-i</i>	(2.53) —>	<i>uḍkīṣumi</i>	'we will not drink'
<i>nīdkīṣ-o-um-i</i>	(2.53) —>	<i>nīdkīṣumi</i>	'we will not stand'
<i>ōṣtkīṣ-o-um-i</i>	(2.53) —>	<i>ōṣtkīṣumi</i>	'we will not say'
<i>po:r-o-um-i</i>	(2.53) —>	<i>po:rumi</i>	'we did not come'
<i>kīy-o-um-i</i>	(2.53) -->	<i>kīyumi</i>	'we did not do'
<i>nīl-o-um-i</i>	(2.53) -->	<i>nīlumi</i>	'we did not stand'
<i>naṛ-o-um-i</i>	(2.53) —>	<i>naṛumi</i>	'we did not walk'
<i>wī:d-o-um-i</i>	(2.53) —>	<i>wī:ḍumi</i>	'we did not run'
<i>kīy-k-um</i>	—>	<i>kīykum</i>	'we will do'
<i>uṇ-k-um</i>	—>	<i>uṇkum</i>	'we will drink'
<i>ōṣt-k-um</i>	—>	<i>ōṣtkum</i>	'we will say'
<i>naṛ-k-um</i>	—>	<i>naṛkum</i>	'we will walk'
<i>pod-ḥ-um-wīṛ</i>	—>	<i>podumwīṛ</i>	'If we come'
<i>pi:-ḥ-um-wīṛ</i>	—>	<i>pi:umwīṛ</i>	'If we go'
<i>naṛḥ-ḥ-um-wīṛ</i>	—>	<i>naṛḥumwīṛ</i>	'If we walk'

4.18.2. Second person singular

{ -p- }

∞ -p- ∞ -py ∞ -ty ∞ -y ∞ -t

4.13.2.1.  $\infty$  -p- occurs after tense and negative suffix.

Ex. <i>pod-<math>\emptyset</math>-p-i</i>	—>	<i>podpi</i>	'come-you (Sg)'
<i>tīd-<math>\emptyset</math>-p-i</i>	—>	<i>tīdpi</i>	'eat-you'
<i>pi:-<math>\emptyset</math>-p-i</i>	—>	<i>pi:pi</i>	'go-you'
<i>nīd-<math>\emptyset</math>-p-i</i>	—>	<i>nīdpi</i>	'stand-you'
<i>pīt-<math>\emptyset</math>-p-i</i>	—>	<i>pītpi</i>	'sow-you'
<i>naṛ<math>\emptyset</math>-<math>\emptyset</math>-p-i</i>	—>	<i>naṛopi</i>	'walk-you'
<i>pod-s-p-i</i>	(2.42,49) —>	<i>pozpi</i>	'came-you'
<i>tīd-s-p-i</i>	(2.44,49) —>	<i>tīzpi</i>	'ate-you'
<i>nīd-s-p-i</i>	(2.44,49) —>	<i>nīzpi</i>	'stood-we'
<i>pīty-s-p-i</i>	(2.26,45,49) —>	<i>pīšpi</i>	'sowed-you'
<i>naṛ<math>\emptyset</math>-s-p-i</i>	(2.41) —>	<i>naṛspi</i>	'walked-you'
<i>po:r-<math>\emptyset</math>-p-i</i>	—>	<i>po:ropi</i>	'you did not come'
<i>nīl-o-p-i</i>	—>	<i>nīlopi</i>	'you did not stand'
<i>tīn-o-p-i</i>	—>	<i>tīnopi</i>	'you did not eat'
<i>uṇ-o-p-i</i>	—>	<i>uṇopi</i>	'you did not drink'
<i>wī:d-o-p-i</i>	—>	<i>wī:ḍopi</i>	'you did not run'
<i>ōšt-o-p-i</i>	—>	<i>ōštōpi</i>	'you did not say'
<i>a:foṛ-o-p-i</i>	—>	<i>a:foṛopi</i>	'you did not talk'
<i>par-o-p-i</i>	—>	<i>paropi</i>	'you did not write'
<i>kīy-o-p-i</i>	—>	<i>kīyopi</i>	'you did not do'
<i>oj-o-p-i</i>	—>	<i>ojopi</i>	'you did not fear'
<i>pūṣoḍ-o-p-i</i>	—>	<i>pūṣoḍopi</i>	'you did not call'
<i>kaṛ-o-p-i</i>	—>	<i>kaṛopi</i>	'you did not milk'
<i>teṛ-o-p-i</i>	—>	<i>teṛopi</i>	'you did not open'

4.18.2.2.  $\infty$ -*py* occurs after tense when it is followed by interrogative.

Ex. <i>pi</i> :- $\emptyset$ - <i>py</i>	—>	<i>pi:py</i>	‘go-you’
<i>pod</i> - $\emptyset$ - <i>py</i>	—>	<i>podpy</i>	‘come-you’
<i>tīd</i> - $\emptyset$ - <i>py</i>	—>	<i>tīdpy</i>	‘eat-you’
<i>ud</i> - $\emptyset$ - <i>py</i>	—>	<i>udpy</i>	‘drink-you’
<i>o:d</i> - $\emptyset$ - <i>py</i>	—>	<i>o:dpy</i>	‘play-you’
<i>kīs</i> - $\emptyset$ - <i>py</i>	—>	<i>kīspy</i>	‘do-you’
<i>nwī:ty</i> - $\emptyset$ - <i>py</i>	—>	<i>nwī:typy</i>	‘lock-you’
<i>pod</i> - <i>s</i> - <i>py</i>	(2.42,49) —>	<i>pozpy</i>	‘came-you’
<i>tīd</i> - <i>s</i> - <i>py</i>	(2.44,49) —>	<i>tīzpy</i>	‘ate-you’
<i>ud</i> - <i>s</i> - <i>py</i>	(2.48,49) —>	<i>uzpy</i>	‘drank-you’
<i>o:d</i> - <i>s</i> - <i>py</i>	(2,48,49) —>	<i>o:zpy</i>	‘played-you’
<i>nwī:ty</i> - <i>s</i> - <i>py</i>	(2.26,47,49) —>	<i>nwī:špy</i>	‘looked-you’

4.18.2.3.  $\infty$ -*ty* occurs after tense when it is preceded by interrogative.

Ex. <i>pi</i> :- $\emptyset$ - <i>ty</i>	—>	<i>pi:ty</i>	‘go-you’
<i>pod</i> - $\emptyset$ - <i>ty</i>	—>	<i>podty</i>	‘come-you’
<i>tīd</i> - $\emptyset$ - <i>ty</i>	—>	<i>tīdty</i>	‘eat-you’
<i>ud</i> - $\emptyset$ - <i>ty</i>	—>	<i>udty</i>	‘drink-you’
<i>par</i> - $\emptyset$ - <i>ty</i>	—>	<i>party</i>	‘write-you’
<i>kīs</i> - $\emptyset$ - <i>ty</i>	—>	<i>kīsty</i>	‘do-you’
<i>o:d</i> - $\emptyset$ - <i>ty</i>	—>	<i>o:dty</i>	‘play-you’
<i>nwī:t</i> - $\emptyset$ - <i>ty</i>	—>	<i>nwī:tty</i>	‘look-you’
<i>karə</i> - $\emptyset$ - <i>ty</i>	—>	<i>karəty</i>	‘milk-you’
<i>püşəde</i> - $\emptyset$ - <i>ty</i>	—>	<i>püşədetty</i>	‘call-you’

4.18.2.4.  $\infty$ -y- occurs after tense and before conditional suffix -wīŕ.

Ex. <i>pod-θ-y-wīŕ</i>	—>	<i>podywīŕ</i>	‘if you come’
<i>tīd-θ-y-wīŕ</i>	—>	<i>tīdywīŕ</i>	‘if you say’
<i>pi:-θ-y-wīŕ</i>	—>	<i>pi:ywīŕ</i>	‘if you go’

4.18.2.5.  $\infty$ -t- occurs after prohibitive suffix -o

Ex. <i>pod-θ-t-i</i>	—>	<i>podoti</i>	‘do not come-you’
<i>tīd-o-t-i</i>	—>	<i>tīdoti</i>	‘do not eat’
<i>ud-o-t-i</i>	—>	<i>udoti</i>	‘do not drink’
<i>naŕθ-o-t-i</i>	—>	<i>naŕθoti</i>	‘do not walk’
<i>nwī:ty-o-t-i</i>	—>	<i>nwī:tyoti</i>	‘do not look’
<i>kwīd-o-t-i</i>	—>	<i>kwīdoti</i>	‘do not quarrel’
<i>ko:t-o-t-i</i>	—>	<i>ko:toti</i>	‘do not show’
<i>wī:rīt-o-t-i</i>	—>	<i>wī:rītoti</i>	‘do not listern’

### Second person plural-

{ -tš- }

$\infty$ -tš, ~š  $\infty$ -š  $\infty$ -š

4.18.2.6.  $\infty$ -tš occurs after tense in declaratives and it occurs after tense when it is followed and preceded by interrogative. It is free variation with -š

Ex. <i>tīd-θ-tš-i</i>	—>	<i>tīdtš-i</i>	‘eat-you (pl.)’
<i>kođ-θ-tš-i</i>	—>	<i>kođtš-i</i>	‘look-you’
<i>kark-θ-tš-i</i>	—>	<i>karktš-i</i>	‘melt-you’
<i>pod-θ-tš-i</i>	—>	<i>podtš-i</i>	‘con.e-you’

<i>sō:d-∅-tš-i</i>	—>	<i>sō:dīši</i>	'arrive-you'
<i>nīd-∅-tš-i</i>	—>	<i>nīdīši</i>	'stand-you'
<i>te:d-∅-tš-i</i>	—>	<i>te:dīši</i>	'do (work)-you'
<i>ni:d-∅-tš-i</i>	—>	<i>ni:dīši</i>	'peepover-you'
<i>ud-∅-tš-i</i>	—>	<i>udīši</i>	'drink' -you'
<i>teškwīd-∅-tš-i</i>	—>	<i>teškwīdīši</i>	'hug-you'
<i>kīdθ-∅-tš-i</i>	—>	<i>kīdīši</i>	'sprinkle-you'
<i>pi:-∅-tš</i>	—>	<i>pi:tš</i>	'go-you'
<i>pod-∅-tš ~</i>	—>	<i>podīš</i>	
<i>pod-∅-š</i>	—>	<i>podš</i>	'come-you'
<i>tīd-∅-ts ~</i>	—>	<i>tīdīš</i>	
<i>tīd-∅-š</i>	—>	<i>tīdš</i>	'eat-you'
<i>kīs-∅-tš</i>	—>	<i>kīstš</i>	'do-you'
<i>nwī:t-∅-tš</i>	—>	<i>nwī:tš</i>	'look-you'
<i>karθ-∅-tš</i>	—>	<i>karθš</i>	'milk-you'
<i>nařθ-∅-tš</i>	—>	<i>nařθš</i>	'walk-you'

4.18.2.7. ∞ -š- occurs after negative.

Ex. <i>po:r-o-š-i</i>	(2.53.)	—>	<i>po:rši</i>	'you did not come'
<i>kīy-o-š-i</i>	(2.53)	—>	<i>kīyši</i>	'you did not do'
<i>ōšt-o-š-i</i>	(2.53)	—>	<i>ōštši</i>	'you did not say'
<i>par-o-š-i</i>	(2.53)	—>	<i>parši</i>	'you did not write'
<i>kač-o-š-i</i>	(2.53)	—>	<i>kačši</i>	'you did not learn'

<i>wī:d-o-š-i</i>	(2.53)	—>	<i>wī:dš-i</i>	‘you did not run’
<i>nīl-o-š-i</i>	(2.53)	—>	<i>nīlš-i</i>	‘you did not stand’
<i>naṛ-o-š-i</i>	(2.53)	—>	<i>naṛš-i</i>	‘you did not walk’
<i>poṛ-o-š-i</i>	(2.53)	—>	<i>poṛš-i</i>	‘you did not lie down’
<i>pī:x-o-š-i</i>	(2.53)	—>	<i>pī:xš-i</i>	‘you did not go’
<i>pīnt-o-š-i</i>	(2.53)	—>	<i>pīntš-i</i>	‘you did not ask’
<i>tīn-o-š-i</i>	(2.53)	—>	<i>tīnš-i</i>	‘you did not eat’

4.18.2.18.  $\infty$  -s- occurs after prohibitive suffix -o.

Ex. <i>pod-o-s-i</i>	—>	<i>podosi</i>	‘do not come-you (pl.)’
<i>pīnt-o-s-i</i>	—>	<i>pīntosi</i>	‘do not ask’
<i>tīd-o-s-i</i>	—>	<i>tīdosi</i>	‘do not eat’
<i>poṭ-o-s-i</i>	—>	<i>poṭosi</i>	‘do not lie down’
<i>pūṣoḍe-o-s-i</i>	—>	<i>pūṣoḍeosi</i>	‘do not call’

4.18.3. *Third person*

*Singular and plural*

{ -t- }

$\infty$  -t-  $\infty$  -u  $\infty$  -k  $\infty$  -n

4.18.3.1.  $\infty$  -t- occurs (1) after tense in declaratives and occurs when it is followed by interrogative and (2) also occurs after negative suffix and it is in free variation with -īy in negative.

Ex. <i>tīd-<math>\emptyset</math>-t-i</i>	—>	<i>tīd̄ti</i> ‘eats—he/she/it eat—they’
<i>pi:-<math>\emptyset</math>-t-i</i>	—>	<i>pi:ti</i> ‘goes—he/she/it go—they’
<i>koḍ-<math>\emptyset</math>-t-i</i>	—>	<i>koḍti</i> ‘looks—he/she/it look—they’
<i>pod-<math>\emptyset</math>-t-i</i>	—>	<i>podti</i> ‘comes—he/she/it come—they’
<i>nīd-<math>\emptyset</math>-t-i</i>	—>	<i>nīd̄ti</i> ‘stands—he/she/it stand—they’
<i>kīs-<math>\emptyset</math>-t-i</i>	—>	<i>kīsti</i> ‘does—he/she/it do—they’
<i>pīṭ-<math>\emptyset</math>-t-i</i>	—>	<i>pīṭti</i> ‘carries—he/she carry—they’
<i>wī:t-<math>\emptyset</math>-t-i</i>	—>	<i>wī:ṭti</i> ‘drives (calf)—he/she drive—they’
<i>ko:t-<math>\emptyset</math>-t-i</i>	—>	<i>ko:ṭti</i> ‘shows—he/she show—they’
<i>kuṭ-<math>\emptyset</math>-t-i</i>	—>	<i>kuṭti</i> ‘pounds—she pound—they’
<i>o:r-<math>\emptyset</math>-t-i</i>	—>	<i>o:ṛti</i> ‘weeps—he/she weep—they’
<i>pi:-s-t-i</i>	(2.45,50) —>	<i>pi:ḍi</i> ‘went—he/she/it/they’

- e:mo:ty-s-t-i* (2.26,45,49,50) —> *e:mo:či*  
'deceived—he/she/they'
- püšodø-s-t-i* (2.41,50) —> *püšodči*  
'called—he/she/they'
- parø-s-t-i* (2.41,50) —> *parči*  
'wrote—he/she/they'
- pi:-ø-t* —> *pi:t* 'goes—he/she  
go—they'
- pod-ø-t* —> *podt* 'comes—he/she  
come—they'
- tīd-ø-t* —> *tīdt* 'eats—he/she/it  
eat—they'
- ud-ø-t* —> *udt* 'drinks—he/she  
drink—they'
- o:d-ø-t* —> *o:dt* 'dances—he  
dance—they'
- kīs-ø-t* —> *kīst* 'does—he/she  
do—they'
- nwī:l-ø-t* —> *nwī:tt* 'looks—he/she  
look—they'
- karø-ø-t* —> *karøt* 'milks—he  
milk—they'
- pi.š-t* (2.50) —> *pi:č* 'went—he/she/it  
went—they'
- pī:x-o-t-i* ~ —> *pī:xoti*
- pī:x-o-īy-i* (2.53) —> *pī:xīyi*  
'he/she/it did not go'

- tīn-o-t-i* ~ —> *tīnoti*  
*tīn-o-īy-i* (2.53) —> *tīnīyi*  
 'he/she/it did not eat'
- uṇ-o-t-i* ~ —> *uṇoti*  
*uṇ-o-īy-i* (2.53) —> *uṇīyi*  
 'he/she/it did not break'
- kīy-o-t-i* ~ —> *kīyoti*  
*kīy-o-īy-i* (2.53) —> *kīyīyi*  
 'he/she/ it did not do (work)'
- po:r-o-t-i* ~ —> *po:roti*  
*po:r-o-īy-i* (2.53) —> *po:rīyi*  
 'he/she/it did not come'
- podkīṣ-o-īy-i* (2.53) —> *podkīṣīyi*  
 'he/she/ they will not come'
- tīḍkīṣ-o-īy-i* (2.53) —> *tīḍkīṣīyi*  
 'he/she/they will not eat'
- uḍkīṣ-o-īy-i* (2.53) —> *uḍkīṣīyi*  
 'he/she/they will not drink'
- pi:kīṣ-o-īy-i* (2.53) —> *pi:kīṣīyi*  
 'he/she/ they will not go'

4.18.3.2. ∞ -u occurs after tense suffix when it is preceded by interrogative.

- Ex. *pi:-ḥ-u* —> *pi:u* 'goes-he/she  
 go-they'
- pod-ḥ-u* —> *podu* 'comes-he/she  
 come-they'
- tīḍ-ḥ-u* —> *tīḍu* 'eats-he/she  
 eat-they'

<i>uḍ-ḡ-u</i>	—>	<i>uḍu</i> ‘drinks-he/she drink-they’
<i>kīṣ-ḡ-u</i>	—>	<i>kīṣu</i> ‘does-he/she do-they,’
<i>nwī:t-ḡ-u</i>	—>	<i>nwī:tu</i> ‘looks-he/she look-they’
<i>karə-ḡ-u</i>	—>	<i>karəu</i> ‘milks-he milk-they’
<i>pūṣoḍə-ḡ-u</i>	—>	<i>pūṣoḍəu</i> ‘calls-he/she call-they’
<i>narə-ḡ-u</i>	—>	<i>narəu</i> ‘walks-he/she/it walk-they’

4.18.3.3.  $\infty$  -*k* occurs after past tense suffix when it is preceded by interrogative.

Ex. <i>pod-s-k</i>	(2.42,49)	—>	<i>poz<sub>k</sub></i> ‘came-he/she/they’
<i>tīḍ-s-k</i>	(2.44,49)	—>	<i>tīḍ<sub>k</sub></i> ‘ate-he/she/they,’
<i>uḍ-s-k</i>	(2.48,49)	—>	<i>uḍ<sub>k</sub></i> ‘drank-he/she/they’
<i>o:ḍ-s-k</i>	(2.48,49)	—>	<i>o:ḍ<sub>k</sub></i> ‘danced-he/she/they’
<i>nwī:ty-s-k</i>	(2.26,47,49)	—>	<i>nwī:ṣ<sub>k</sub></i> ‘looked-he/she/they’
<i>karə-s-k</i>	(2.41)	—>	<i>kar<sub>s</sub>k</i> ‘milked-he/they’
<i>pūṣoḍə-s-k</i>	(2.41)	—>	<i>pūṣoḍ<sub>s</sub>k</i> ‘called-he/she/they’

- naṛθ-s-k* (2.41) —> *naṛsk*  
 ‘walked-he/she/they ,’
- aṭo-s-k* (2.41) —> *aṭsk*  
 ‘measured-he/she/they’
- pi:ṛfoθ-s-k* (2.41) —> *pi:ṛfosk*  
 ‘kissed-he/she’
- paft-s-k* (2.41) —> *paḥsk*  
 ‘kicked-he/she/they’
- teṣamt-s-k* (2.41) —> *teṣamsk*  
 ‘performed hair-cutting and  
 naming ceremony’

4.18.3.4. ∞ -n occurs after tense suffix and before conditional suffix -wīṛ.

- Ex. *pod-θ-n-wīṛ* —> *podnwīṛ* ‘if he comes’  
*pi:θ-n-wīṛ* —> *pinwīṛ* ‘if he goes’  
*naṛθ-θ-n-wīṛ* —> *naṛθnwīṛ* ‘if he walks’  
*uḍ-θ-n-wīṛ* —> *uḍnwīṛ* ‘if he drinks’  
*tīḍ-θ-n-wīṛ* —> *tīḍnwīṛ* ‘if he eats’

#### 4.19. Declarative

{ S<sub>2</sub>- Tense- Pers. sfx. } —  
 { S<sub>1</sub>- Neg- Pers. sfx. }

{ -i }

~ -i

4.19. ~ -i

- Ex. *pod-θ-pin-i* —> *podpini* ‘come-I’

<i>tīd-θ-pin-i</i>	—>	<i>tīd̄pini</i>	‘eat-I’
<i>koḍ-θ-pin-i</i>	—>	<i>koḍpini</i>	‘look-I’
<i>pod-s-pin-i</i>	(2.42,49)	—>	<i>pozpini</i> ‘came-I’
<i>te:d̄-s-pin-i</i>	(2.44,49)	—>	<i>te:z̄pini</i> ‘did (work)-I’
<i>po:r-o-en-i</i>	(2.53)	—>	<i>po:reni</i> ‘I did not come’
<i>pī:x-o-en-i</i>	(2.53)	—>	<i>pī:xeni</i> ‘I did not go’
<i>podkīḡ-o-en-i</i>	(2.53)	—>	<i>podkīḡeni</i> ‘I will not come’
<i>tīd-θ-pim-i</i>	—>	<i>tīd̄pimi</i>	‘eat-we (excl.)’
<i>pīḡ-θ-pim-i</i>	—>	<i>pīḡpimi</i>	‘carry-we’
<i>pī:x-o-em-i</i>	—>	<i>pī:xemi</i>	‘we did not go’
<i>nīl-o-em-i</i>	—>	<i>nīlemi</i>	‘we did not stand’
<i>koḍ-θ-pum-i</i>	—>	<i>koḍpumi</i>	‘look-we (incl.)’
<i>nīd-θ-pum-i</i>	—>	<i>nīd̄pumi</i>	‘stand-we’
<i>kīy-o-um-i</i>	(2.53)	—>	<i>kīyumi</i> ‘we did not do’
<i>pi:θ-p-i</i>	—>	<i>pi:pi</i>	‘go-you (sg.)’
<i>naṛθ-θ-p-i</i>	—>	<i>naṛθpi</i>	‘walk-you (sg.)’
<i>pod-s-p-i</i>	(2.42,49)	—>	<i>pozpi</i> ‘came-you’
<i>tīn-o-p-i</i>	—>	<i>tīnopi</i>	‘you did not eat’
<i>pod-o-t-i</i>	—>	<i>podoti</i>	‘do not come’
<i>kark-θ-tš-i</i>	—>	<i>karktši</i>	‘melt-you (pl.)’
<i>kaṛ-o-š-i</i>	—>	<i>kaṛoši</i>	‘you did not learn’
<i>pod o-ḡ-i</i>	—>	<i>podosi</i>	‘do not come-you (pl.)’

<i>tīd-θ-t-i</i>	—>	<i>tīd̄ti</i>	‘eats—he/she/it, eat—they’
<i>pod-θ-t-i</i>	—>	<i>podti</i>	‘comes—he/she/it, come—they’
<i>pī:x-o-t-i</i>	—>	<i>pī:xoti</i>	‘he/she/it did not go’

## 4.20. Conditional

S<sub>2</sub>- Tense- Pers. Sfx-
$$\{ -wīr \}$$

$$\sim - wīr$$
4.20.1.  $\sim - wīr$  occurs after personal suffix.

Ex. <i>pod-θ-en-wīr</i>	—>	<i>podenwīr</i>	‘if I come’
<i>pod-θ-y-wīr</i>	—>	<i>podywīr</i>	‘if you come’
<i>pod-θ-n-wīr</i>	—>	<i>podnwīr</i>	‘if he comes’
<i>naṛθ-θ-en-wīr</i>	—>	<i>naṛθenwīr</i>	‘if I walk’
<i>naṛθ-θ-y-wīr</i>	—>	<i>naṛθywīr</i>	‘if you walk’
<i>naṛθ-θ-n-wīr</i>	—>	<i>naṛθnwīr</i>	‘if he walks’
<i>pī:-θ-en-wīr</i>	—>	<i>pī:enwīr</i>	‘if I go’
<i>pī:-θ-y-wīr</i>	—>	<i>pī:ywīr</i>	‘if you go’
<i>pī:-θ-n-wīr</i>	—>	<i>pī:nwīr</i>	‘if he goes’
<i>īd-θ-en-wīr</i>	—>	<i>īdenwīr</i>	‘if I say’
<i>īd-θ-y-wīr</i>	—>	<i>īdywīr</i>	‘if you say’
<i>īd-θ-n-wīr</i>	—>	<i>īdnwīr</i>	‘if he says’

## 4.21. Classification of verbal stems

In the Toda language the past tense and the present-future (as well as some other formations) are formed on a

special stem that may be called the 'secondary stem' ( $S_2$  of Emeneau). This secondary stem historically corresponds to the past stem of Tamil-Malayalam and some other languages. The secondary stem is formed by adding one of the following suffixes to the verb base. 1.  $\emptyset$  2.  $t$  3.  $d$  and 4.  $y$ . To quote Emeneau (1967): "The great majority of Toda  $S_2$  stems is represented by such contrasting sets as:  $\bar{i}x-$ ,  $\bar{i}xy-$  'to slip, be slippery'  $\bar{i}x-$ ,  $\bar{i}x\emptyset-$  'to separate oneself from others,'  $\bar{i}xf-$ ,  $\bar{i}xt-$  'to make people separate, open (loop', bangle),  $kuf-$ ,  $kufy-$  'to pound (clothes in washing), load (gun)',  $uf-$ ,  $uft-$  'to shake off, empty (bag)', On the basis of these and many other items three  $S_2$  morphs can be set up 1.  $-y-$  2.  $-\emptyset-$  3.  $-t-$ . Two verbs ending in  $!$  have an  $S_2$  suffix 4.  $-d-$ . This is in contrast with  $-t-$  and  $-y-$  after stems ending in  $!$ " So all the Toda verbs are classified into four major classes.

1.  $y$  class
2.  $\emptyset$  class
3.  $t$  class
4.  $d$  class

It is also to be noted that verbs have to be classified on the basis of transitivity versus intransitivity. The verbs which are capable of taking object are called transitive and others are called intransitive. The transitive can be denoted either inherently (i.e. without any suffixes) or by the addition of some suffixes. The derived transitives are formed by the addition of suffixes to the intransitive verbs. So the inherent intransitive are divided into two sub-classes, namely.

1. M. B. Emeneau, 'The South Dravidian languages', Journal of the American Oriental Society, Vol 87, No. 4, 374-76, 1967.

1. Intransitive (Intr.<sub>1</sub>) which cannot be made into transitive by the addition of transitive suffix.

2. Intransitive (Intr.<sub>2</sub>) which can be made into transitives by the addition of transitive suffix.

Intransitive (Intr.<sub>2</sub>) are found to fall into three classes.

1. Intransitives which take transitive suffix *-t-*.

2. Intransitives which take transitive suffix *-c-*.

and 3. Intransitives which take transitive suffix *-f-*.

The classification on the basis of the secondary stem formative and the classification on the basis of transitive versus intransitive are cross classifications. However, they can be clubbed under one group. Four major classes which are already set up on the basis of secondary stem formative as a basic, the intransitive and transitive classification is incorporated within that. So each of the four major classes is sub divided into inherent transitive, intransitive, and Intransitive<sub>1</sub>.

## Verbs

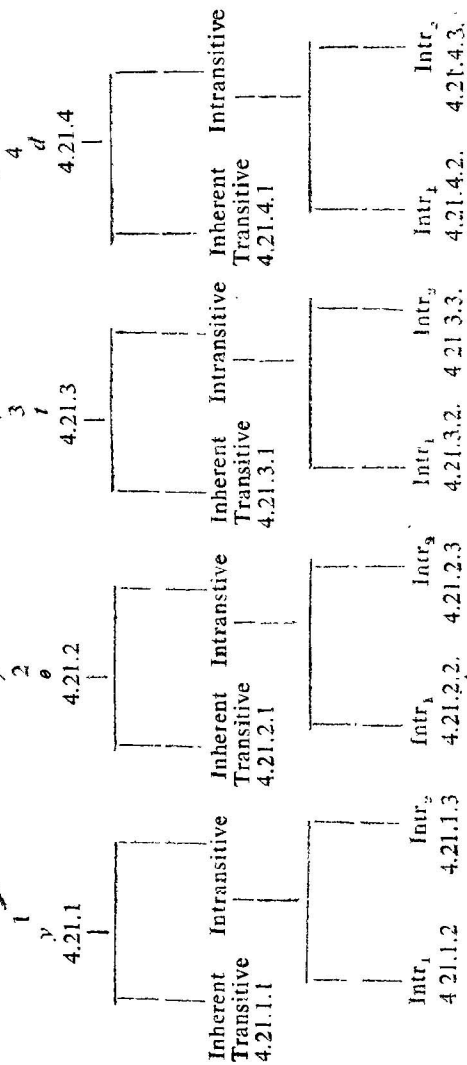

*y class*4.21.1.1. *Inherent Transitives*

<i>ōn</i>	‘count’
<i>kaɾt</i>	‘send’
<i>ūrβ</i>	‘play (flute)’
<i>uβ</i>	‘agree’
<i>oɫ</i>	‘pour’
<i>pīn</i>	‘weave’
<i>po:t</i>	‘spread’ (grains)
<i>pu:t</i>	‘tie’
<i>toɫ</i>	‘push’
<i>wī:ʒ</i>	‘drive (calf from udder)’
<i>paʒ</i>	‘seize, touch’
<i>koʒ</i>	‘build (house)’
<i>sop</i>	‘suck’
<i>kō:ɾ</i>	‘winnow’
<i>ki:c</i>	‘comb’
<i>ōʒt</i>	‘say’
<i>ki:ɾ</i>	‘tear’
<i>kuɫ</i>	‘knock, pound’
<i>noʔ</i>	‘lick’
<i>nob</i>	‘trust, believe’
<i>kum</i>	‘pound (grain) with light stroke’
<i>eɾy</i>	‘throw’
<i>tō:ʒt</i>	‘close (the <i>ti</i> dairy)’

<i>o:t</i>	'shake violently'
<i>ud</i>	'smear'
<i>tü:t</i>	'wander'
<i>tī:k</i>	'stop'
<i>kwīøk</i>	'peck'
<i>nwī:t</i>	'look'
<i>na:g</i>	'play'
<i>kü:p</i>	'kill'
<i>wī:ø</i>	'read'
<i>kīd</i>	'sprinkle'
<i>to:g</i>	'support'
<i>mu:t</i>	'smell'
<i>pīt</i>	'sow'
<i>aʃp</i>	'clean'
<i>kuf</i>	'pound (clothes in washing)'
<i>e:mo:t</i>	'deceive'
<i>pint</i>	'ask'
<i>part</i>	'pray'
<i>müç</i>	'cover'
<i>u:c</i>	'throw away'
<i>koc</i>	'bite'
<i>tī:k</i>	'stop (man, animal)'
<i>te:t</i>	'fold'
<i>paʃ</i>	'marry (woman)'
<i>poðø</i>	'enjoy'
<i>ušt</i>	'take off (ring, bangle, shirt)'

*kušt* 'build with stone'

4.21.1.3. *Intransitive<sub>2</sub>*

4.21.1.3.1. can be transitivized by adding *-t*.

<i>kālx</i>	'be stirred up'
<i>omx</i>	'be pressed down'
<i>ī:x</i>	'descend'
<i>alx</i>	'shake'
<i>tu:x</i>	'hang'
<i>po:x</i>	'flow down completely'
<i>o:x</i>	'become'
<i>arx</i>	'be subdued'
<i>ni:x</i>	'crawl'
<i>tīrx</i>	'turn'
<i>wīθx</i>	'get ready'
<i>wīŋx</i>	'wither'
<i>karx</i>	'melt, dissolve'
<i>kuṛx</i>	'be short'
<i>moṛx</i>	'bend'
<i>mīsx</i>	'move slightly vertically'
<i>usx</i>	'move horizontally'
<i>meṣx</i>	'(things) become soaked and softened'
<i>nōṛx</i>	'become tall'
<i>u:x</i>	'glide along'
<i>mu:x</i>	'be destroyed'

<i>pīəx</i>	'be squeezed'
<i>twīəx</i>	'be at point of readiness'
<i>toəx</i>	'smash'
<i>mulx</i>	'be destroyed'
<i>twalx</i>	'be out of plumb'
<i>oɔg</i>	'be quite'
<i>wīrg</i>	'be crushed'
<i>morg</i>	'become bent'
<i>wa:g</i>	'turn over'
<i>ʃɪrb</i>	'twist'
<i>o:d</i>	'dance'
<i>kuɪr</i>	'join'
<i>ni:r</i>	'be stretched'
<i>o:r</i>	'become dry'
<i>mo:r</i>	'change'
<i>tō:r</i>	'improve (in health, wealth)'
<i>u:r</i>	'be filtered'
<i>po:r</i>	'fly'
<i>twī:r</i>	'be visible'

.21.1.3.2. can be transitivized by adding *-c-*.

<i>kak</i>	'vomit'
<i>o:d</i>	'dance'
<i>mu:x</i>	'destroy'
<i>o:r</i>	'(dispute) is settled'
<i>ʃi:r</i>	'settle (dispute)'

## Class

4.21.2.1. *Inherent transitive*

<i>par</i>	'write'
<i>kaṛ</i>	'milk'
<i>kīy</i>	'do'
<i>kaṛ</i>	'steal'
<i>aṭ</i>	'measure'
<i>teṛ</i>	'open'
<i>pe:ṛ</i>	'thatch'
<i>maṛ</i>	'forget'
<i>pūṣoḍ</i>	'call'
<i>kof</i>	'be turned upside down'
<i>aḍ</i>	'dig'
<i>pīḍ</i>	'fall'
<i>kaṛ</i>	'steal'
<i>kaṛ</i>	'churn'
<i>pīy</i>	'beat'
<i>kwīy</i>	'pluck'
<i>eṭy</i>	'throw, cut'
<i>pi:ṛfor</i>	'kiss'

4.21.2.3. *Intransitive<sub>2</sub>*4.21.2.3.1. can be transitivized by adding *-t-*

<i>ōḍ</i>	'rise'
-----------	--------

<i>naɾ</i>	'walk'
<i>kaɖ</i>	'cross'
<i>to:y</i>	'be lowered'
<i>kary</i>	'be singed'
<i>pīry</i>	'become parted'
<i>mary</i>	'fall'
<i>ti:y</i>	'be singed'
<i>īry</i>	'fall down'
<i>wīry</i>	'(joints) crack'

4.21.2.3.2. can be transitivized by adding *-c-*.

<i>ko:y</i>	'be hot'
<i>koɖy</i>	'disappear'
<i>tīry</i>	'twist'
<i>naɖ</i>	'organise'
<i>toɳy</i>	'cool, calm'
<i>pīxy</i>	'become tight'
<i>pūry</i>	'become full'
<i>pīry</i>	'spring forth, (boil) breaks'
<i>tūɟy</i>	'become clear'

#### † Class

4.21.3.1. *Inherent transitive*

<i>a:foɾ</i>	'talk'
<i>uf</i>	'shake up'

<i>pīr</i>	‘carry’
<i>twī:y</i>	‘wash (clothes)’
<i>kwīr</i>	‘give’
<i>uny</i>	‘think’
<i>ke:ṭ</i>	‘hear’
<i>wī:rīd</i>	‘listen’
<i>īd</i>	‘put, place’
<i>paḥ</i>	‘kick’
<i>tuḥ</i>	‘burn’
<i>swī:l</i>	‘be defeated’
<i>ofy</i>	‘calm’
<i>wīdy</i>	‘save’
<i>ko:f</i>	‘watch’
<i>aḥ</i>	‘cut, reap’
<i>uḥ</i>	‘plough’
<i>kiṭy</i>	‘ladle out (food)’
<i>teṭ</i>	‘pay (fine, debt)’
<i>mu:neṭ</i>	‘like’
<i>oḥ</i>	‘cook’

#### 4.21.3.3. *Intransitive.*

##### 4.21.3.3.1. Can be transitivized by adding *-f*

<i>ōd</i>	‘rise’
<i>kwāl</i>	‘become emaciated’
<i>twād</i>	‘be polluted’
<i>aḥ</i>	‘shut’

<i>taɾ</i>	'prevent'
<i>nen</i>	'think'
<i>pax</i>	'divide'
<i>kwaɾ</i>	'cut'
<i>twa:n</i>	'sweep'
<i>peɕ</i>	'grow'
<i>waɾ</i>	'break'
<i>kaɾ</i>	'tighten'
<i>neɾ</i>	'fill'

4.21.3.3.2. Can be transitivized by adding *-e-*

<i>kaɕ</i>	'learn'
<i>twi:ɕ</i>	'be defeated'
<i>mony</i>	'for give'
<i>pīɾ</i>	'let go'
<i>töɖ.xöɾ</i>	'be tired'
<i>o:poɾ</i>	'be caught'

*d* Class

4.21.4.1. *Inherent transitive*

<i>tīn</i>	'eat'
<i>uŋ</i>	'drink'
<i>īn</i>	'say'
<i>koł</i>	'steal'
<i>pe:ɾf</i>	'be born'
<i>kwīł</i>	'carry (corpse)'
<i>o:l</i>	'rule'

4.21.4.3. *Intransitive*<sub>2</sub>4.21.4.3.1. Can be transitivized by adding *-t-*

<i>sö:r</i>	'lean against, arrive'
<i>u:l</i>	'roll'
<i>tu:l</i>	'roll up'
<i>ko:n</i>	'see'
<i>pī:l</i>	'tumble over'
<i>no:l</i>	'get wet'
<i>pu:l</i>	'wear around neck'
<i>kiskwīl</i>	'tickle'
<i>teškwił</i>	'hug'
<i>nī:l</i>	'be stretched out'

4.21.4.3.2. Can be transitivized by adding *-c-*.

<i>nīl</i>	'stand'
------------	---------

It is worth mentioning that in Toda there are certain verbs like the following which can be used both as transitive and intransitive.

Ex. <i>moɾy</i>	'fold (intr., tr.)'
<i>swīł</i>	'drop (of liquid) (intr., tr.)'
<i>wīły</i>	'hide (Intr. tr.)'
<i>toły</i>	'sprinkle (intr., tr.)'



- iīd-s-θ-iθ-s-pin-i* (2.44,49,41)  
 → *iīzīspini* 'I had eaten'
- uđ-s-θ-iθ-s-pin-i* (2.43,49,41)  
 → *užispiini* 'I had drunken'
- karθ-s-θ-iθ-s-pin-i* (2.41)  
 → *karšispiini* 'I had churned'
- karθ-s-θ-iθ-s-pin-i* (2.41)  
 → *karšispiini* 'I had milked'
- kwīrt-s-θ-iθ-s-pin-i* (2.41)  
 → *kwīrtispiini* 'I had given (to him)'

## 4.22.2. Trial

S<sub>2</sub>- Past tense -VP-

{ -nwī:ty- }

~ -nwī:ty

## 4.22.2.1. ~-nwī:ty-

- Ex. *pinty-s-θ-nwī:ty-s-pin-i* (2.25,45,4) 26,47,49)  
 → *pinšnwī:spini* 'I tried to ask him'
- a:foṭ-s-θ-nwī:ty-s-pin-i* (2.47,49,26,47,49)  
 → *a:foṣnwī:spini* 'I tried to talk with him'
- iīd-s-θ-nwī:ty-s-pin-i* (2.44,49,26,47,49)  
 → *iīznwī:spini* 'I tried to eat (meal)'
- (poṣm) *kwīrt-s-θ-nwī:ty-s-pin-i* (2.41,26,47,49)  
 → *kwīrtš nwī:spini* 'I tried to give (money)'

- (a:s) *kīs-s-Ø-nwī:ty-s-pin-i* (2.18,26,47,49)  
 —> *kīs nwī:špini* 'I tried to build (house)'  
*ud-s-Ø-nwī:ty-s-pin-i* (2.48,49,26,47,49)  
 —> *uznwī:špini* 'I tried to drink (arrack)'

4.22.3. *Durative*S<sub>2</sub>- Past tense -VP-

{ -wīl- }

~ -wīl-

## 4.22.3.1. ~ -wīl-

- Ex. (si:t) *pare-s-Ø-wīl-Ø-pin-i* (2.41)  
 —> *parswīlpini* 'I am writing (letter)'  
 (īr) *karø-s-Ø-wīl-Ø-pin-i* (2.41)  
 —> *karšwīlpini* 'I am milking (buffalo)'  
 (twī:r) *tīd-s-Ø-wīl-Ø-pin-i* (2.44,49)  
 —> *tīzswīlpini* 'I am eating (meals)'  
 (so:roy) *ud-s-Ø-wīl-Ø-pin-i* (2.48,49)  
 —> *uzswīlpini* 'I am drinking (arrack)'  
 (poṇm) *kwīrt-s-Ø-wīl-Ø-pin-i* (2.41)  
*kwīrswīlpini* 'I am giving  
 (money to him)'

4.22.4. *Obligatory*S<sub>2</sub>-

{ -to- }

~ -to-

## 4.22.4.1. ~ -to-

- Ex. *tīd-θ-to-īy-i* (2.53) —> *tīd̄tīyi*  
 ‘he has to eat’
- uḍ-θ-to-īy-ī* (2.53) —> *uḍtīyi*  
 ‘he has to drink’
- pi:-θ-to-īy-i* (2.53) —> *pi:tīyi*  
 ‘he has to go’
- pīt-θ-to-īy-i* (2.53) —> *pīttīyi*  
 ‘they have to carry’
- pod-θ-to-īy-i* (2.53) —> *podtīyi*  
 ‘he has to come’
- wī:d-θ-to-īy-i* (2.53) —> *wī:d̄tīyi*  
 ‘he has to run’
- karθ-θ-to-īy-i* (2.53) —> *karətīyi*  
 ‘he has to milk’
- naṛθ-θ-to-īy-i* (2.53) *naṛətīyi*  
 ‘he has to walk’
- pi:-θ-to-pin-i* —> *pi:topini*  
 ‘I have to go’
- pi:-θ-to-pum-i* —> *pi:topumi*  
 ‘we have to go’
- pi:-θ-to-p-i* —> *pi:topi*  
 ‘you have to go (sg.)’
- pi:-θ-to-š-i* —> *pi:toši*  
 ‘you have to go (pl.)’
- kīs-θ-to-pin-i* —> *kīstopini*  
 ‘I have to do’

<i>kīs-θ-to-pum-i</i>	—>	<i>kīstopumi</i> 'we have to do'
<i>kīs-θ-to-p-i</i>	—>	<i>kīstopi</i> 'you have to do'
<i>kāre-θ-to-pin-i</i>	—>	<i>karətopini</i> 'I have to milk'
<i>karə-θ-to-pum-i</i>	—>	<i>karətopumi</i> 'we have to milk'
<i>karə-θ-to-p-i</i>	—>	<i>karətopi</i> 'you have to milk (sg.)'
<i>kāre-θ-to-š-i</i>	—>	<i>karətoši</i> 'you have to milk (pl.)'
<i>naṛə-θ-to-pin-i</i>	—>	<i>naṛətopini</i> 'I have to walk'
<i>naṛə-θ-to-pum-i</i>	—>	<i>naṛətopumi</i> 'we have to walk'
<i>naṛə-θ-to-p-i</i>	—>	<i>naṛətopi</i> 'you have to walk'

4.22.5. *Potential*S<sub>2</sub>

$$\left\{ \begin{array}{l} -kīd- \\ \sim -kīd- \end{array} \right\}$$
4.22.5.1.  $\sim -kīd-$ 

Ex. *pod-kīd-θ-pin-i* —> *podkīdḡpini*  
'I can come'

<i>uḍ-kīḍ-ḡ-pin-i</i>	—>	<i>uḍkīḍpini</i> 'I can drink'
<i>wī:d-kīḍ-ḡ-pin-i</i>	—>	<i>wī:ḍkīḍpini</i> 'I can run'
<i>waṛt-kīḍ-ḡ-pin-i</i>	—>	<i>waṛtkīḍpini</i> 'I can break'
<i>pīṭ-kīḍ-ḡ-pin-i</i>	—>	<i>pīṭkīḍpini</i> 'I can carry'
<i>naṛḡ-kīḍ-ḡ-pin-i</i>	—>	<i>naṛḡkīḍpini</i> 'I can walk'
<i>pi:-kīḍ-ḡ-pin-i</i>	—>	<i>pi:kīḍpini</i> 'I can go'
<i>kaṛḡ-kīḍ-ḡ-pin-i</i>	—>	<i>kaṛḡkīḍpini</i> 'I can churn'

## 4.22.6. Possibility

S<sub>2</sub>- Tense -VP-Aux- Tense-

{ -kin- }

~ -kin-

## 4.22.6.1. ~ -kin-

Ex. *pod-s-ḡ-iḡ-s-kin-ṭy-i* (2.42,49,41)  
 —> *poziskinīyi* 'he/she/it/they  
 might have come'

(so:roy) *uḍ-s-ḡ-iḡ-s-kin-ṭy-i* (2 48,49,41)  
 —> *uḍiskinīyi* 'he/she/they  
 might have eaten (arrack)'

- (*po:jo:rtk*) *pi:-s-ø-iø-s-kin-īy-i* (2.45,41)  
 —> *pi:šiskinīyi* ‘he might have gone  
 (to Ootacamund)’  
*tīd-s-ø-iø-s-kin-īyi* (2.44,49,41)  
 —> *tīziskinīyi* ‘he/she/it  
 might have eaten’  
*kīs-s-ø-iø-s-kin-īy-i* (2.18,41)  
 —> *kīsiskinīyi* ‘he/they  
 might have done’

## 4.22.7. Aspectual

S<sub>2</sub>-

{ -fīt- }

~ -fīt-

## 4.22.7.1. ~ -fīt-

- Ex. *kīs-fīt-ø-pin-i* —> *kīsfītpini*  
 ‘I shall certainly do’  
*pi:fīt-ø-pin-i* —> *pi:fītpini*  
 ‘I shall certainly go’  
*pi:fīt-ø-t-i* —> *pi:fītti*  
 ‘he shall certainly go’  
*pod-fīt-ø-pin-i* —> *podfītpini*  
 ‘I shall certainly come’  
*pinty-fīt-ø-pin-i* (2.26) —> *pintfītpini*  
 ‘I shall certainly ask’  
*pod-fīt-ø-t-i* —> *podfītti*  
 ‘he shall certainly come’

- öšty-fīt-θ-pin-i* (2.26) —> *öštfītṣpini*  
 'I shall certainly say'
- öšty-fīt-t-i* (2.26) —> *öštfītṣi*  
 'he shall certainly say'
- tīd-fīt-θ-pin-i* —> *tīdfītṣpini*  
 'I shall certainly eat'
- te:d-fīt-θ-pin-i* —> *te:dfītṣin*  
 'I shall certainly do'
- pod-fīt-s-pin-i* (2.47,49) —> *podfītṣpini*  
 'I had come'
- kīs-fīt-s-pin-i* (2.47,49) —> *kīsfītṣpiin*  
 'I had done'
- wī:d-fīt-s-pin-i* (2.47,49) —> *wī:dfītṣpini*  
 'I had run'
- koḍ-fīt-s-pin-i* (2.47,49) —> *koḍfītṣpini*  
 'I had seen'
- kaṛt-fīt-s-pin-i* (2.47,49) —> *kaṛtfītṣpini*  
 'I had sent'
- kaṭ-fīt-s-pin-i* (2.47,49) —> *kaṭfītṣpini*  
 'I had learnt'



## Appellative Verbs

5.0. Appellative verbs are those which cannot take tense suffixes but can take or are capable of taking other verbal suffixes like relative participle, personal suffixes etc<sup>1</sup>. Appellative verbs behave like verbs syntactically.

### 5.1. Stems

List of appellative bases is given below.

<i>etu:d-</i>	'big'
<i>nal-</i>	'good'
<i>pue-</i>	'new'

---

1 See S. Agesthalingom and S. V. Shanmugam, *The Language of Tamil Inscriptions (1250-1350 A. D.)*. Annamalai Universtiy, 1970.

<i>per-</i>	'great'
<i>pa:fn-</i>	'old'
<i>kīrwīd-</i>	'small'
<i>wīl-</i>	'good'
<i>wīd-</i>	'is / are'
<i>o:re-</i>	'not'

## 5.2. Relative participle

{ -foy- }

∞ -foy ∞ ∅

5.2.1. ∞-foy occurs after the base *wīd-*

Ex. *wīdfoy oṭ* 'person who was there'

5.2.2. ∞ ∅ occurs elsewhere

*o:re-∅-o:ṭ* → *o:re o:ṭ* 'person who is not there'

*etu:d-∅-o:ṭ* → *etu:d o:ṭ* 'person who is great'

## 5.3. Suffixes

### 5.3.1. Quality nominalizer

St-

{ -my }

~ -my

~ -my occurs with the following bases *naṭ-*, *puṅ-* and *per-*.

Ex. <i>naṭ-my</i> (2.10)	→	<i>nanmy</i>	'goodness'
<i>puṅ-my</i>	→	<i>puṅmy</i>	'newness'
<i>per-my</i>	→	<i>permy</i>	'greatness'

## 5.3.2. Impersonal suffix

This is common to all person and gender-number.

St-

{ -y }

~ -y

~ -y occurs after the bases *wīd-*, *o:re-*, and *wīl-*.

Ex. <i>wīd-y</i>	—>	<i>wīdy</i>	'is/are'
<i>o:re-y</i>	—>	<i>o:rey</i>	'not'
<i>wīl-y</i>	—>	<i>wīlty</i>	'it is good'
<i>aə ay a:s o:rey</i>			'he is not in the house'
<i>ay ɪr al o:rey</i>			'that buffalo is not there'
<i>ay a:ɕ iy a:s wīdy</i>			'that man is in the house'
<i>ay ɪr il wīdy</i>			'that buffalo is here'
<i>aə upum wīlty</i>			'he is very good'
<i>aə podfoy wīlty</i>			'it is good that he came'
<i>iy ku:x əsa:ɾ aylku:x wīlty</i>			'that girl is good than this girl'
<i>iy ɪr əsa:ɾ ay ɪr wīlty</i>			'that buffalo is good than this buffalo'

## 5.4. Gender-number markers

## 5.4.1. Masculine

{ o:ɕ }

~ -o:ɕ

5.4.1.1.  $\sim -o:\xi$ 

Ex. <i>wī yo:\xi</i>	'one who is good'
<i>etu:\dot{o}:\xi</i>	'one who is great'

5.4.2. *Neuter*
 $\{ \text{īyi} \}$ 
 $\sim -\text{īyi}$ 
5.4.2.1.  $\sim -\text{īyi}$ 

Ex. <i>etu:\dot{q}īyi</i>	'one which is good'
<i>kīṛwī\dot{q}īyi</i>	'one which is small'

5.5. *Stem alternants*
 $\{ \text{wī}|\text{-} \}$ 
 $\infty \text{wī}|\text{-} \quad \infty \text{wī}|\text{-}$ 

5.5.1.1.  $\infty \text{wī}|\text{-}$  occurs before the adverbial *-kīs*.

Ex. <i>wī \text{-}kīs</i>	$\rightarrow$	<i>wī \text{-}kīs</i>	'being good'
---------------------------	---------------	-----------------------	--------------

5.5.1.2.  $\infty \text{wī}|\text{-}$  occurs elsewhere.

Ex. <i>wī \text{-}y</i>	$\rightarrow$	<i>wī y</i>	'good'
-------------------------	---------------	-------------	--------

 $\{ \text{pu}\text{e}\text{-} \}$ 
 $\infty \text{pu}\text{e}\text{-} \quad \infty \text{pu}\text{e}\text{-}$ 

5.5.2.1.  $\infty \text{pu}\text{e}\text{-}$  occurs before *o:\xi*.

Ex. <i>pu}\text{e}\text{-}o\xi</i>	'guest or new person'
------------------------------------	-----------------------

5.5.2.2.  $\infty \text{pu}\text{e}\text{-}$  occurs elsewhere.

Ex. <i>pu}\text{e}\text{-}pu:\text{txu}\xi y</i>	'new cloak'
<i>pu}\text{e}\text{-}ogod y</i>	'new shop'

# 6

## Clitics

6.0. Clitics are those particles which are bound. They are of three types.

- [i] Pro-clitics
- [ii] Post-clitics and
- [iii] En-clitics

### 6.1. Pro-clitics

Pro-clitics are those which occur before another clitic or noun. They are of two types.

- [i] Demonstratives
- [ii] Interrogatives

## 6.2. Post-clitics

Post-clitics are those which occur after pro-clitics.

## 6.3. En-clitics

Enclitics are those which occur after pro-clitics, post-clitics, noun or verb. They are divided into five types.

1. Encl<sub>1</sub> are those which occur after noun.
2. Encl<sub>2</sub> are those which occur after verb.
3. Encl<sub>3</sub> are those which occur after noun and verb.
4. Encl<sub>4</sub> are those which occur after noun.
5. Encl<sub>5</sub> are those which occur after post-clitics.

## 6.1. Pro-clitics

### 6.1.1. Distant demonstrative

{ a- }

∞ a:- ∞ a-

6.1.1.1. ∞ a:- occurs before post-clitic *-nk*.

Ex. a:-nk 'there'

6.1.1.2. ∞ a- occurs elsewhere.

Ex. a-l	'there'
a-f	'that-side'
a- <i>tk</i>	'that-much'
a- <i>e</i>	'that-he / she / it'
a-y	'that'
a- <i>t̄fok</i>	'that-time'
a-t	'that-many'

6.1.2. *Proximate demonstrative*

$$\left\{ i- \right\}$$

$$\infty i- \sim i:- \sim -\bar{i}-$$
6.1.2.1.  $\infty i:$  occurs before post-clitic *-nk*.Ex. *i:-nk* 'here'6.1.2.2.  $\sim \bar{i}-$  occurs before *-t*.Ex.  $\bar{i}-tk$  'this-much'*\bar{i}-tfok* 'this-time (now)'*\bar{i}-t* 'this-many'6.1.2.3.  $\sim i-$  occurs elsewhere.Ex. *i-l* 'here'*i-t* 'this-side'*i-ø* 'this-he / she / it'*i-y* 'this'6.1.3. *Interrogative*

$$\left\{ e- \right\}$$

$$\infty o: \sim e- \sim e:-$$
6.1.3.1.  $\infty o:-$  occurs before non-neuter suffix *-ry*.Ex. *o:-ry* 'who'6.1.3.2.  $\sim e-$  occurs before stop.Ex. *e-gʷs* 'how'*e-tfok* 'what-time'

<i>e-ik</i>	'how much'
<i>e-d̄</i>	'what day'
<i>e-t̄</i>	'which side'
<i>e-t</i>	'how many'

6.1.3.3.  $\sim e:-$  occurs elsewhere.

Ex. <i>e:-o</i>	'which'
<i>e:-l</i>	'where'
<i>e:-y</i>	'which'
<i>e:-nk</i>	'where (place)'

## 6.2. Post-clitics

### 6.2.1. Place clitics

{ *-nk* }

$\sim -nk \sim -l$

Both are in freevariation

#### 6.2.1.1. $\sim -nk$

Ex. <i>i:-nk</i>	'here'
<i>a:-nk</i>	'there'
<i>e:-nk</i>	'where'

#### 6.2.1.2. $\sim -l$

Ex. <i>a-l</i>	'there'
<i>i-l</i>	'here'
<i>e:-l</i>	'where'

6.2.2. *Clitic of side*

$$\left\{ \begin{array}{l} -t \\ \sim -t \end{array} \right\}$$
6.2.2.1.  $\sim -t$ 

Ex. $a-t$	'that-side'
$i-t$	'this-side'
$e-t$	'which-side'

6.2.3. *Clitic of time (day)*

$$\left\{ \begin{array}{l} -d \\ \sim -d \end{array} \right\}$$
6.2.3.1.  $\sim -d$ 

Ex. $a-d$	'that-day'
$i-d$	'this-day or to-day'
$e-d$	'which day'

6.2.4. *Clitic of time (general)*

$$\left\{ \begin{array}{l} -tfok \\ \sim -tfok \end{array} \right\}$$
6.2.4.1.  $\sim -tfok$ 

Ex. $i-tfok$	'this-time (now)'
$a-tfok$	'that-time'
$e-tfok$	'when'

6.2.5. *Clitic of quantity (count)*

$$\{ -t \}$$

$$\sim -t$$
6.2.5.1.  $\sim -t$ 

Ex. <i>a-t</i>	'that-many'
<i>ī-t</i>	'this-many'
<i>e-t</i>	'how-many'

6.2.6. *Clitic of quantity (mass)*

$$\{ -tk \}$$

$$\sim -tk$$
6.2.6.1.  $\sim -tk$ 

Ex. <i>a-tk</i>	'that-much'
<i>ī-tk</i>	'this-much'
<i>e-tk</i>	'how-much'

6.2.7. *Clitic of manner*

$$\{ -gīs \}$$

$$\sim -gīs$$
6.2.7.1.  $\sim -gīs$ 

Ex. <i>ī-gīs</i>	'this-manner'
<i>a-gīs</i>	'that-manner'
<i>e-gīs</i>	'what-manner'

6.2.8. *Clitic of adjective*

$$\left\{ \begin{array}{l} -y \\ \sim -y \end{array} \right\}$$
6.2.8.1.  $\sim -y$ 

Ex. <i>a-y</i>	'that (adj.)'
<i>i-y</i>	'this (adj.)'
<i>e:-y</i>	'which (adj.)'
<i>ay ĩr</i>	'that-buffalo'
<i>iy ĩr</i>	'this-buffalo'
<i>e:y ĩr</i>	'which buffalo'
<i>ay a:s</i>	'that-house'
<i>iy a:s</i>	'this-house'
<i>e:y a:s</i>	'which-house'

6.2.9. *Clitic of personal ending*

$$\left\{ \begin{array}{l} -\emptyset \\ \sim -\emptyset \end{array} \right\}$$
6.2.9.1.  $\sim -\emptyset$ 

Ex. <i>i-\emptyset</i>	'this-he / she / it'
<i>a-\emptyset</i>	'that-he / she / it'
<i>e:-\emptyset</i>	'which'

6.3. **En-clitics**6.3.1. *Encl<sub>1</sub>*

6.3.1.1. *Even*

$$\{ -m \}$$

$$\sim -m$$
6.3.1.1.1.  $\sim -m$  occurs with noun.

Ex. <i>peṭyxen-m</i>	'even Pelikan'
<i>sinmury-m</i>	'even Sinmury'
<i>o:n-m</i>	'even I'
<i>aθ-m</i>	'even he'

6.3.1.2. *Completeness*

$$\{ -m \}$$

$$\sim -m$$
6.3.1.2.1.  $\sim m$ 

Ex. <i>pot-m</i>	'ten (all)'
<i>ifoθ-m</i>	'twenty (all)'
<i>pot o:ṭ-m</i>	'all the ten persons'
<i>ifoθ īr-m</i>	'all the twenty buffaloes'
<i>iy īr ifoθ-m mo:ṛkin</i>	'I sell all the twenty buffaloes'

6.3.1.3. *Clitic of emphasis*

$$\{ -e: \}$$

$$\sim -e:$$

## 6.3.1.3.1. ~ -e:

Ex. o:n-e:	'I (with emphasis)'
aθ-e:	'he (with emphasis)'
ro:jn-e:	'king (with emphasis)'

## 6.3.1.4. Clitic of intense emphasis

$$\{ -to:n \}$$

$$\sim -to:n$$

## 6.3.1.4.1. ~ -to:n

Ex. mutyxen-to:n	'It is Mutykan'
aθ-to:n	'it is he (with emphasis)'
kogfoŋy ĩr-to:n	'it is that buffalo'

## 6.3.1.5. Clitic of comparison

$$\{ -eaʒa:ɾ \}$$

$$\sim -eaʒa:ɾ$$

## 6.3.1.5.1. ~ -eaʒa:ɾ occurs after the noun.

Ex. ay o:ŋ eaʒa:ɾ	'than that man'
ay ĩr eaʒa:ɾ	'than that buffalo'
ay o:ŋ eaʒa:ɾ iy o:ŋ wĩŋy o:ŋ ĩyi	'This man is better than that man'

## 6.3.1.6 Clitic of choice

$$\{ o: \dots o: \}$$

$$\sim o: \dots o:$$

6.3.1.6.1. ~ *o:* ..... *o:* occurs after the nouns.

Ex. *o:n-o: aθ-o:* 'either I or he'

6.3.1.7. *About*

{ -*paty* }

~ -*paty*

6.3.1.7.1. ~ -*paty* occurs after the noun.

Ex. *mutna:g paty* 'about Mutnas'  
*sinmury paty* 'about Sinmury'  
*ku:x paty* 'about girl' -  
*mox paty* 'about boy'  
*an paty a:foʔoʔi* 'do not talk about him'  
*en paty a:foʔoʔi* 'do not talk about me'

6.3.1.8. *Clitic of possibility*

{ -*em* }

~ -*em*

6.3.1.8. ~ -*em* occurs after the noun.

Ex. *ni:em* 'atleast you'  
*makolkem* 'atleast to-morrow'

6.3.1.9. *Clitic of restriction*

{ -*mo:tīrm* }

~ -*mo:tīrm* ~ *maʔm*

Both are in freevariation.

## 6.3.1.9.1. ~ -mo:tirm

Ex.	<i>o:n mo:tirm</i>	'I alone'
	<i>em mo:tirm</i>	'we alone'
	<i>to:j mo:tirm</i>	'Taj alone'
	<i>o:n mo:tirm pi:pini</i>	'I go alone'
	<i>aə mo:tirm endīyi</i>	'It alone is mine'

## 6.3.1.9.2. ~ -maṭm

Ex.	<i>aə maṭm</i>	'he alone'
	<i>aə maṭm wīṭy o:ṭīyi</i>	'he alone is a good person'

6.3.2. *Encl*<sub>2</sub>6.3.2.1. *Clitic of concession of fact*

{ -um }

~ -um

## 6.3.2.1.1. ~ -um

Ex.	<i>pod-n-um</i>	→	<i>podnum</i>	'even if he comes'
	<i>kīs-n-um</i>	→	<i>kīsnum</i>	'even if he does'
	<i>pono:y podnum swī:ṭy ti:rīyi</i>			
	'even if Ponay comes, matter is not going to settle'			

6.3.3. *Encl*<sub>3</sub>6.3.3.1. *Conjunctive*

{ -m ..... -m }

~ -m ..... -m

## 6.3.3.1.1. ~ -m ..... -m

Ex. <i>īr-m koṛ-m</i>	'buffalo and calf'
<i>ni:r-m po:s-m</i>	'water and milk'
<i>aə-m o:n-m</i>	'he and I'

## 6.3.3.2. Interrogative

{ -a: }

~ -a:

## 6.3.3.2.1. ~ -a: occurs after noun and verb.

Ex. <i>pi:tro:jn-a:</i>	'is Peterrajan?'
<i>mutna:s-a:</i>	'is Mutnas?'
<i>paškin-a:</i>	'shall I come?'
<i>wīḍ-a:</i>	'is it there?'
<i>taškin-a:</i>	'shall I give?'
<i>(īr) paṭkin-a:</i>	'shall I catch (buffalo)?'

6.3.4. Encl<sub>2</sub>

## 6.3.4.1. Ordinal

{ -a:n }

∞ -a:n ∞ -a:fīθ

6.3.4.1.1. ∞ a:n occurs before *te:ti* 'day' alone.

Ex. <i>e:ḍ-a:n te:ti</i>	'second day'
<i>mu:ḍ-a:n te:ti</i>	'third day'
<i>no:ng-a:n te:ti</i>	'fourth day'
<i>ūj-a:n te:ti</i>	'fifth day'

6.3.4.1.2.  $\infty$  -a:fīθ occurs elsewhere.

- Ex. e:d-a:fīθ mox 'second son'  
 mu:d-a:fīθ mox 'third son'  
 no:ng-a:fīθ ku:x 'fourth daughter'  
 üj-a:fīθ ku:x 'fifth daughter'

6.3.5. *Encl<sub>3</sub>*

6.3.5.1. *Universal clitic*

{ -m }  
 ~ -m

6.3.5.1.1. ~ -m

- Ex. e:nk-m 'every where'  
 e-gīs-m 'at any rate'

6.3.5.2. *Indefinite clitic*

{ -isky }  
 ~ -isky

6.3.5.2.1. ~ -isky

- Ex. e-gīs-isky → egīsisky 'somehow or other'



# 7

## Particles

### 7.0. Classification

Particles are those which cannot take either case or tense suffixes but they can occur independently or with noun or verb in a sentence. The particles are capable of taking clitics.

### 7.1. Free particles

Free particles are further classified into two types viz

1. Those particles which can modify a verb and
2. Those particles which can qualify a noun

#### 7.1.1. *Verb modifiers*

- 7.1.1.1. { *īnmīl* } 'hereafter'  
                  ~ *īnmīl*  
                  ~ *īnmīl*

Ex. *īnmīl podoṭi* 'you should not come hereafter'  
*īnmīl kwīlīyi* 'don't want hereafter'

7.1.1.2. { *īnm* } 'still'  
 ~ *īnm*  
 ~ *īnm*

Ex. *īnm pe:kīyi* 'still is necessary'

7.1.1.3. { *maṛč* } 'again'  
 ~ *maṛč* ~ *tīrm*

Both are in free variation

Ex. *aə maṛč pi:či* 'he went again'  
*aə tīrm pi:či* 'he went again'  
*o:n maṛč pozpini* 'I came again'  
*o:n tīrm pozpini* 'I came again'

7.1.1.4. { *mely* } 'slowly'  
 ~ *mely*  
 ~ *mely*

Ex. *mely pī:x* 'go slowly'  
*ak kīrwīd mely podti*  
 'That child comes slowly.'

7.1.1.5. { *sary* } 'alright/yes'  
 ~ *sary*

~ *sary*

Ex. *sary ošt* 'alright, tell'

- 7.1.1.6. { *pokīn* } 'without any purpose'  
 ~ *pokīn*  
 ~ *pokīn*  
 Ex. *pokīn pozpini* '(I) came without any purpose'

- 7.1.1.7. { *tanyk* } 'alone'  
 ~ *tanyk*  
 ~ *tanyk*  
 Ex. *tanyk pi:ti* '(he) goes alone'

- 7.1.1.8. { *pern* } 'speedily'  
 ~ *pern*  
 ~ *pern*  
 Ex. *pern pī:x* 'go speedily'

- 7.1.1.9. { *ixø* } 'away'  
 ~ *ixø*  
 ~ *ixø*  
 Ex. *ixø nīl* 'stand away'

## 7.1.2. Noun qualifiers

- 7.1.2.1. { *īnwīd* } 'another'  
 ~ *īnwīd*  
 ~ *īnwīd*  
 Ex. *ank īnwīd pony wīdy* 'he has another work'

7.1.2.2. { *upum* } 'much/more'

~ *upum*

~ *upum*

Ex. *upum o:t* 'more persons'  
*upum ĩr* 'more buffaloes'

7.1.2.3. { *ala:k* } 'lonely'

~ *ala:k*

~ *ala:k*

Ex. *ala:k a:g* 'lonely house'  
*ala:k me:n* 'lonely tree'

7.1.2.4. { *ity* } 'little bit'

∞ *ity* ∞ *siṭyk*

7.1.2.4.1. ∞ *ity* occurs before noun *pax* 'tobacco' only.

Ex. *ity pax* 'little bit tobacco'

7.1.2.4.2. ∞ *siṭyk* occurs before *twi:r*, *peṇ* etc.

Ex. *siṭyk twi:r* 'little bit food'  
*siṭyk peṇ* 'little bit butter'

7.1.2.5. { *melyš* } 'soft'

~ *melyš*

~ *melyš*

Ex. *melyš torp* 'soft dhoti'  
*melyš paṛ* 'soft cloth'

7.2. Particles which occur after a noun or verb and also as a free form.

7.2.1. Particles which occur after a noun.

7.2.1.1. { *mu:lim* } 'through'

~ *mu:lim* ~ *ne:ra:r*

Both are in freevariation.

Ex. *an mu:lim* 'through him'  
*an ne:ra:r* 'through him'  
*mutna:s mu:lim* 'through Mutnas'  
*mutna:s ne:ra:r* 'through Mutnas'

7.2.1.2. { *wīde:d* } 'little bit'

~ *wīde:d*

~ *wīde:d*

Ex. *po:s wīde:d* 'little bit milk'  
*ašky wīde:d* 'little bit rice'

7.2.1.3. { *muda:l* } 'before'

∞ *muda:l* ∞ *muda:lk*

7.2.1.3.1. ∞ *muda:lk* occurs after *en-*

Ex. *en muda:lk* 'before me'

7.2.1.3.2. ∞ *muda:l* occurs elsewhere.

Ex. *enk muda:l* 'before me'

7.2.2. Particles which occur after noun and relative participle.

7.2.2.1. { *mo:tiry* } 'similar'

~ *mo:tiry*

~ *mo:tiry*

Ex. *īr mo:tiry* 'like buffalo'

*tonm mo:tiry* 'like cattle'

*me:n mo:tiry* 'like tree'

*öštyfoy mo:tiry* (2.26) —> *öštfoy mo:tiry*  
'in the same way as said'

*pintyfoy mo:tiry* (2.26) —> *pintfoy mo:tiry*  
'in the same way as (one) asked'

7.2.2.2. { *pīn* } 'after / afterwards'

~ *püda:l*, ~ *pin*

Both are in freevariation.

Ex. *aek püda:l* 'after that'

*aek pīn* 'after that'

*podfoy pīn* 'after coming'

7.2.3. Particles which occur after or before noun and also as free forms. Free form implies the existence of some noun in the deep level.

7.2.3.1. { *kī:l* } 'below'

∞ *kī:l-* ∞ *ki:*

7.2.3.1.1. ∞ *ki:* occurs as an attribute to a noun.

Ex. *ki: fary* 'lower line'

*ki: tīn* 'lower platform'

*ki: kwīter* 'lower floor where ladies sitting'

*ki: te:s* 'plains'

7.2.3.1.2. ∞ *ki:l* occurs elsewhere.

Ex. *aək ki:l* 'below that'

*ki:l* 'below'

7.2.3.2. { *me:l* } 'above'

∞ *me:l-* ∞ *me:-*

7.2.3.2.1. ∞ *me:-* occurs as an attribute to a noun.

Ex. *me: po:y* 'upper mouth'

*me: tal* 'upper portion of waist'

*me: kūt* 'upper portion of saree'

*me: kwax* 'end of upper line'

*me: po:lgoṇ* 'upper pole'

7.2.3.2.2. ∞ *me:l* occurs elsewhere.

Ex. *tīṭ me:l* 'on the hill'

*aək me:l* 'above that'

*me:l* 'above'

7.2.3.3. { *uṭ* } 'insids'

∞ *uṭ*, ∞ *uṭg*

7.2.3.3.1. ∞ *uṭ* occurs as an attribute to a noun.

Ex. *uṭ kwīs* 'inner room'

7.2.3.3.2.  $\infty$  *uḷg* occurs elsewhere.

Ex. <i>a:s uḷg</i>	‘inside the house’
<i>to:w uḷg</i>	‘inside the blanket’
<i>poḷy uḷg</i>	‘inside the dairy’
<i>uḷg</i>	‘inside’

7.2.3.4. { *pīṛmun* } ‘outside’

$\infty$  *pīṛmun*  $\infty$  *pīṛmutk*

7.2.3.4.1.  $\infty$  *pīṛmun* occurs as an attribute to a noun.

Ex. <i>pīṛmun kwīṣ</i>	‘outer room’
------------------------	--------------

7.2.3.4.2.  $\infty$  *pīṛmutk* occurs elsewhere.

Ex. <i>a:s pīṛmutk</i>	‘outside the house’
<i>pīṛmutk</i>	‘outside’

7.2.3.5. { *noṛf* } ‘centre’

$\infty$  *noṛ-*  $\infty$  *noṛf*

7.2.3.5.1.  $\infty$  *noṛ* occurs as an attribute to a noun.

Ex. <i>noṛ ja:m</i>	‘midnight’
<i>noṛ a:s</i>	‘middle house’
<i>noṛ poxo</i>	‘midday (exactly 12 o’ clock)’
<i>noṛ kwīṣ</i>	‘middle room (of dairy)’

7.2.3.5.2. ∞ *norf* occurs elsewhere.

Ex. *kīrwīd norf* 'in the middle of child'  
*norf* 'centre/middle'

7.2.3.6. { *mutyk* } 'under'

~ *mutyk*

~ *mutyk*

Ex. *an mutyk* 'under that'

7.2.4. Particle which occur after verb.

{ *a:ɾm* } 'until'

~ *a:ɾm*

7.2.4.1. ~ *a:ɾm*

Ex. *paša:ɾm* 'till (some one) comes'



## Echo Words

Echo words are frequent in the language families of India. The following Dravidian languages viz Tamil, Toda, Kannada, Kota, Kodagu, Telugu, Kuvi and Kolami have more prominency in having echo words. Toda language is particularly rich in the formation of this kind.

Echo words are usually formed by changing the initial syllable into *ki* or *ki:*. *Ki* occurs if the original word contains short vowel in the first syllable whereas *ki:* occurs if it contains a long vowel in the first syllable. Echo words have no lexical meaning at all.

[C]  $\check{v}$   $\rightarrow$  *ki-*

[C]  $\bar{v}$   $\rightarrow$  *ki:-*

Ex. <i>a:s ki:s</i>	'house and the like'
<i>par kir</i>	'things and the like'
<i>poṣy kiṣy</i>	'temple and the like'
<i>kor kir</i>	'calf and the like'
<i>maḍ kid</i>	'head and the like'
<i>pu:txuṣy ki:txuṣy</i>	'cloak and the like'
<i>po:s ki:s</i>	'milk and the like'
<i>nīy kīy</i>	'ghee and the like'
<i>moj kij</i>	'butter milk and the like'
<i>mod kid</i>	'churning rod and the like'
<i>pu:f ki:f</i>	'flower and the like'
<i>tīt kīt</i>	'fire and the like'
<i>potm kitm</i>	'grain and the like'
<i>kapoty kipoty</i>	'jaggery and the like'
<i>aṣky kiṣky</i>	'rice and the like'
<i>up kip</i>	'salt and the like'
<i>pōlk kilk</i>	'lamp and the like'
<i>tojmox kijmox</i>	'Toda woman and the like'
<i>mošt kišt</i>	'axe and the like'
<i>me:ṇ ki:ṇ</i>	'tree and the like'
<i>pīṇ kīṇ</i>	'vessel and the like'
<i>po:dč ki:dč</i>	'adze and the like'
<i>mox kix</i>	'boy and the like'
<i>moč kič</i>	'cot and the like'

# 9

## Syntax

9.0. The syntactic component consists of two kinds of rules, constituent structure rules (Phrase structure rules) and transformation rules. The constituent structure rules specify the grammatical categories and their relation to each other in the deep structure of the sentences of a language. The transformational rules are responsible for the surface structure which are derived from the deep structure. Transformational rules operate on constituent structure.

### 9.1. Constituent structure rules

$$1. S \rightarrow NP + PP$$

A sentence consists of an *NP* which stands for a noun, a noun phrase or a noun clause and *PP* which stands for a predicate phrase.

$$2. \quad PP \quad \rightarrow \quad \left\{ \begin{array}{l} NP + [copula] \\ VP \end{array} \right\}$$

There are two basic types of sentences [ $NP + VP$  and  $NP + NP + (copula)$ ] and all other types accounted for as being derived from these basic types.

Here,  $NP + NP$  type is the equational type and  $NP + VP$  is the subject-verb predicate type.

$NP$  which is immediately dominated by  $S$  performs the function of subject. On the other hand  $NP$  which is immediately dominated by  $PP$  always functions as predicate.

$NP + VP$ :

*Mutyxe:n pi:či*      'Muttikan went'

$NP + NP + [copula]$ :

*aə ka:wxwĩtŋ ĩyi*      'He is Kawkuttan'

$$3. \quad VP \quad \rightarrow \quad [TM] + VP_1$$

$TM$  stands for time expression which will be expanded later (See rule 27). In a verb predicate sentence we may or may not have time expression [ $TM$ ] and so it is placed as optional item.

*pičyxe:n mune:ɾ pi:či*      'Pelikan went day before yesterday'

*o:n ĩne:ɾ pozpini*      'I came yesterday'

$$4. \quad VP_1 \quad \rightarrow \quad [case] + VP_2$$

Case represents the casual expressions and this is further expanded by the next rule.

5. *Case* → *case* + [*case*]

This is a recursive rule with one restriction. That is to say, the same case should not be taken twice in a simple sentence. Toda has the maximum of four cases occurring in a simple sentence.

*NP* + *Acc.* + *Abl.* + *Soc.* + *Dat.* + *Vb.*

*o:n kwĩṛki:ḡyn kwa:ṛəũnyšn enpody*

*küşuk po:döšpini*

'I asked *kwarkiry* to come with me to  
Lovedale mund from *kwa:ṛəũny* mund'

Eventhough theoretically all the cases can combine with each other (cases) the following are the combinations of cases found in my Toda material.

$$\begin{array}{l}
 \text{Obj.} + \left( \begin{array}{l} \text{Ins.} \\ \text{Soc.} \\ \text{Dat.} + [\text{Soc.}] \\ \text{Abl.} \\ \text{Loc.} + [\text{Soc.}] \\ \text{Purp} + [\text{Ins.}] \end{array} \right) \\
 \\
 \text{Soc.} + \left( \begin{array}{l} \text{Obj.} + [\text{Loc.}] \\ \text{Dat.} \\ \text{Purp.} + [\text{Dat.}] \\ \text{Abl.} + \left\{ \begin{array}{l} \text{Dat.} \\ \text{Purp.} \end{array} \right\} \end{array} \right) \\
 \\
 \text{Ins.} + \left( \begin{array}{l} \text{Obj.} + [\text{Abl}] \\ \text{Abl.} + [\text{Dat.}] \\ \text{Soc.} \\ \text{Dat.} \\ \text{Loc.} \end{array} \right)
 \end{array}$$

$$\text{Abl.} + \left( \begin{array}{l} \text{Obj.} + \{\text{Purp.}\} \\ \text{Soc.} + \{\text{Dat.}\} \\ \text{Dat.} \\ \text{Purp.} \end{array} \right)$$

$$\text{Dat.} + \left( \begin{array}{l} \text{Obj.} \\ \text{Ins.} + \{\text{Abl.}\} \\ \text{Soc.} \\ \text{Purp.} \end{array} \right)$$

$$\text{Purp.} + \left( \begin{array}{l} \text{Obj.} \\ \text{Abl.} \\ \text{Soc.} + \{\text{Abl.}\} \end{array} \right)$$

$$\text{Loc.} + \left( \begin{array}{l} \text{Obj.} \\ \text{Soc.} \\ \text{Dat.} \\ \text{Purp.} \end{array} \right)$$

*Obj.*

*o:n an püşođspini* 'I called him'

*Obj. + Ins*

*o:n İrn moštii kü:pšpini* 'I killed buffalo with axe'

*Obj. + Soc.*

*ka:wxwīṭṇ pilsodṇ enpody karči*  
'Kawkuttan send Pilsed  
with me'

*Obj. + Dat. + Soc.*

*o:n an mođk ko:swīṭ po:döšpini*  
'I asked him to come to münd  
with money'

*Obj. + Abl.*

*ay o:ṭ tan ko:tfoyn aṭṣn po:döšpini*  
'That person asked his wife to  
come from there'

*Obj. + Loc. + Soc.*

*o:n īne:r nīn melga:s modṣ pi:tro:jnwīr nwī:ṣpini*

‘Yesterday I saw you at Melgas  
mund with Peter Rajan’

*Obj. + Purp. + Ins.*

*o:n pumn ango:y tu:ryiṣ arṭpini*

‘I cut fruit by knife for his  
sake’

*Soc.*

*mutna:s anpody pi:či*

‘Mutnas went with him’

*Soc. + Obj.*

*o:n īne:r sinmurypody nīmn koṣpini*

‘I saw you yesterday with  
Sinmury’

*Soc. + Obj. + Loc.*

*o:n īne:r ka:wxwīṭṭpody nīmn o:ṣatṣ koṣpini*

‘I saw you yesterday with  
Kawkuttan on the way’

*Soc. + Dat.*

*o:n anpody pirgo:ṛk pi:pini*

‘I shall go to *pirgo:ṛ* with him’

*Soc. + Purp.*

*o:n nīnpody aego:yto:n poṣpini*

‘I came with you for that  
purpose’

*Soc. + Purp. + Dat.*

*o:n an pody aego:y am modk pi:ṣpini*

‘I went to that mund with him  
for that purpose’

*Soc. + Abl.*

*o:n mutna:spody aʃsn pozpini*

‘I came with Mutnas from there’

*Soc. + Abl. + Dat.*

*o:n anpody pojo:rtʃsn pirgo:ʃk pozpini*

‘I came with him from Ootacamund to Kota Nad mund’

*Soc. + Abl. + Purp.*

*o:n pi:tro:jnpody pojo:rtʃsn nīngo:yto:n pozpini*

‘I came with Peter Rajan from Ootacamund for your sake’

*Ins.*

*o:n moʃtit kwartpini*

‘I cut with axe’

*Ins. + Obj.*

*o:n moʃtit īrn kù:pšpini*

‘I killed the buffalo with an axe’

*Ins. + Obj. + Abl.*

*o:n nīn a:lto:n an aʃsn po:döšpini*

‘I asked him to come from there only because of you’

*Ins. + Abl. + Dat.*

*o:n ana:lto:n moʃtxö:ʃsn küšuk pozpini*

‘I came from *moʃtxö:ʃ* mund to Lovedale mund because of him’

*Ins. + Soc.*

*Sinmury ena:lto:n anpody pi:či*

‘Sinmury went with him only because of me’

Ins. + Dat.

*ana:l enk upum kaṣṭm īyi* 'It is very troublesome for me  
because of him'

Ins. + Loc.

*Pīnap enā:lto:n ka:ṣmodṣ wīdy*  
'Ponap is in the Kandal mund  
because of me'

Abl.

*o:n ogodykubṣn pozpini* 'I came from Kotagiri'

Abl. + Obj. + Purp.

*o:n sotyṣn an nīngo:y'e:spozpini*  
'I brought it from shandy only  
for your sake'

Abl + Soc.

*o:n ogodykubṣn mutna:ṣpody pozpini*  
'I came with Mutnas from  
Kotagiri'

Abl. + Soc. + Dat.

*o:n te:lu:rṣn anpody kūṣuk pozpini*  
'I came with him to Lovedale  
mund from Sholur'

Abl. + Dat.

*o:n pojorṣn kelck pozpini* 'I came from Ootacamund for  
the work'

Abl. + Purp.

*ak ku:x ku:nu:rṣn engo:yto:n a:nk pi:čī*  
'That girl went there from  
Coonur only for my sake'

Dat.

*ay o:t̄ pojo:rtk pi:ti* 'he goes to Ootacamund'

Dat. + Obj.

*o:n ank an kwīṛspini* 'I gave him that'

Dat. + Ins.

*o:n mi:t̄pa:wk ana:lto:n pi:špini*  
'I went to Mettupalayam only  
'because of him'

Dat. + Ins. + Abl.

*mutna:s pīrgo:rk ana:lto:n meḷga:s moḍḡn pi:či*  
'Mutnas went to Kodanad  
mund from Garden mund only  
because of him'

Dat. + Soc.

*o:n pojo:rtk anpody pi:špini*  
'I went to Ootacamund with  
him'

Dat. + Purp.

*o:n ank so:royg:oy poṇm kwīṛspini*  
'I gave him money for arrack'

Purp

*o:n nīngo:y i:nk pozpini* 'I came here for your sake'

Purp. + Obj.

*o:n angoy ṛn kū:pšpini* 'I killed buffalo only for his  
sake'

Purp. + Abl.

*kwī:f engo:y kwī:ko:lgn pi:či*

‘Kota went from Kota village  
for my sake’

Purp. + Soc.

*o:n nīngo:yto:n anpođy pozpini*

‘I came with him for your sake’

Purp. + Soc. + Abl.

*o:n tōwbnīsgo:y anpođy ku:lu:ršn pozpini*

‘I came with him from Guda-  
lur for the sake of Tebnis’

Loc.

*aə ka:šmodš wīdy*

‘He is in Kandal mund’

Loc. + Obj.

*o:n pojo:rtš an kožpini*

‘I saw him in Ootačamund’

Loc. + Soc.

*o:n pođyš anpođy pi:špini*

‘I went with him in the  
bullock cart’

Loc. + Dat.

*o:n ma:fkīdš poayk pořm piňšpini*

‘I asked money from Badaga  
for the bullock cart’

Loc. + Purp.

*ma:f sotyš siťygo:y ki:č mo:rči*

‘Badaga sold potato in shandy  
for the sake of chettiar’

6. Case  $\rightarrow$   $\left. \begin{array}{l} \text{Obj.} \\ \text{Ins.} \\ \text{Soc.} \\ \text{Dat.} \\ \text{Abl.} \\ \text{Loc.} \\ \text{Purp.} \end{array} \right\}$

7.  $VP_2 \rightarrow$  [Adv] +  $VP_3$

Adv. stands for adverb.

*aə pern naʀəti* 'He walks fast'

*ak kīrwīd mely naʀəti*  
'That child walks slowly'

8. Adv  $\rightarrow$  [ $\acute{S}$ ] + Adv<sub>1</sub>

$\acute{S}$  stands for a sentence that can occur as constituent sentence which is embedded into a matrix sentence. This is useful to derive the complex sentences like,

*aə pod pīn o:n muk pī:xkin*  
1 2 3 4 5 6

I will go up after he comes  
4 6 5 3 1 2

by embedding the constituent sentence,

*aə podti* 'He will come'  
1 2

into the adverb of the matrix sentence,

*o:n pīn muk pī:xkin*  
1 2 3 4

I will go up after  
1 4 3 2

9.  $\text{Adv}_1 \rightarrow [\text{Adv}_{\text{part.}}] + [\text{Adv}_{\text{man.}}] + [\text{Adv}_1]$

There are three types of adverbs and they are all abbreviated here.  $[\text{Adv}_{\text{part.}}]$  stands for adverb of particles like *mařc* 'again' *iřm* 'again' *iřmīl* 'hereafter' etc;  $[\text{Adv}_{\text{man.}}]$  stands for adverb of manner like *iğīs* 'in this manner' *agīs* 'in that manner' *egīs* 'in what manner' and  $[\text{Adv}_1]$  stands for adverb of limit like *a:řm* 'until' *ne:řk* 'till' etc. It is possible to have constituents to be embedded into all these adverbs, such detailed study is not attempted here.

$\text{Adv}_{\text{part.}} + \text{Adv}_1.$

*mařč a ne:řk pi:či* 'Again he went till that end'

$\text{Adv}_{\text{part.}} + \text{Adv}_{\text{man.}}$

*mařč o:n öšťfoj mo:tiry kīy*  
'you do it again in the way  
which I said'

$\text{Adv}_{\text{part.}} + \text{Adv}_{\text{man.}} + \text{Adv}_1.$

*mařč aə o:n öšťfoj mo:tiry a ne:řkm pi:či*  
'he went again till that in the  
way which I said'

10.  $\text{Adv}_{\text{part.}} \rightarrow \left\{ \begin{array}{l} \text{Adv}_{\text{part}_1.} \\ \text{Adv}_{\text{part}_2.} \end{array} \right\}$

$\text{Adv}_{\text{part}}$  is further divided into  $\text{Adv}_{\text{part}_1.}$  and  $\text{Adv}_{\text{part}_2.}$

11. Adv<sub>part<sub>1</sub></sub> → *em*

*o:nem paškin* 'atleast I will come'

12. Adv<sub>part<sub>2</sub></sub> →  $\left\{ \begin{array}{l} \textit{mařč} \quad \text{'again'} \\ \textit{tīrm} \quad \text{'again'} \\ \textit{īnmīl} \quad \text{'hereafter'} \\ \textit{īnm} \quad \text{'yet, still'} \end{array} \right\}$

*tojmox mařč pi:či* 'Toda woman went again'

*o:n tīrm pozpini* 'I came again'

*īnmīl podoči* 'won't come hereafter'

*ank īnm twī:r pe:kīyi* 'he wants food more'

*īnm pořm pe:kīyi* 'still need money'

13. Adv<sub>man.</sub> →  $\left\{ \begin{array}{l} \text{Adv}_{\text{man}_1} \\ \text{Adv}_{\text{man}_2} \end{array} \right\}$

Adv<sub>man<sub>1</sub></sub> represents expressions like *agīs* 'in that manner', *igīs* 'in this manner', *egīs* 'in what manner' *a mo:tiry* 'in that way' *i mo:tiry* 'in this way' *e mo:tiry* 'in what way' and Adv<sub>man<sub>2</sub></sub> represents expression like *tanyk* 'lonely' etc.

14. Adv<sub>man<sub>1</sub></sub> →  $\left\{ \begin{array}{l} \text{Adv}_{\text{man}_{\text{sim.}}} \\ \text{Adv}_{\text{man}_{\text{com.}}} \end{array} \right\}$

Simple adverb of manner [Adv<sub>man<sub>sim.</sub></sub>] represents expressions like *agīs*, *igīs* and complex adverb of manner [Adv<sub>man<sub>com.</sub></sub>] represents expressions like *i mo:tiry* and *a mo tiry* etc.

<i>aə ɪgīs kīsti</i>	‘he does it in this manner’
<i>ak ku:x agīs kīsti</i>	‘that girl does it in that manner’
<i>ni: ɪgīs kīsoʃi</i>	‘you should not do in this manner’
<i>ni: i mo:tiry kīsoʃi</i>	‘you should not do in this way’

15.  $\text{Adv}_{\text{man}_2} \rightarrow \text{tanyk}$ .

*ak ku:x tanyk pi:či* ‘that girl went lonely’

16.  $\text{Adv}_1 \rightarrow \left\{ \begin{array}{l} \text{ne:r}k \\ \text{kī}d_k \end{array} \right\}$

*mod kīd\_k* ‘till the village’

*a ne:r\_k* ‘till that’

17.  $\text{VP}_s \rightarrow \left\{ \begin{array}{l} \text{Vd} \\ \text{Vb} \end{array} \right\}$

Vd represents defective verbs like *o:rəy* ‘no’ *wīd\_v* ‘is/exist’, *pe:kīyī* ‘(is) necessary’ *kwīlīyī* ‘(is) not necessary’ etc.

Toda has two types of verb bases. Vb which represents the Toda verb base, is further expanded by the following rule.

18.  $\text{Vd} \rightarrow \left\{ \begin{array}{l} \text{Vd}_p \\ \text{Vd}_n \end{array} \right\}$

$Vd_p$  represents positive defective verbs and  $Vd_n$  represent negative defective verbs.

$Vd_p$  : *enk aθ pe:k īyi* 'I want it'

$Vd_n$  : *enk aθ kwīl īyi* 'I don't want that'

*an kīdş poŋm wīdy* 'He has money'

19.  $Vb \rightarrow \left\{ \begin{array}{l} Vb_1 \\ Vb_2 \end{array} \right\}$

Toda has two types of stems which we call simple stem [ $S_1$ ] and secondary stem [ $S_2$ ]. In Toda language, verbs have a secondary stem [ $S_2$ ] which forms the basis for the past tense and of the present - future tense (as well as of some other formation).

$Vb_1$  represents the simple stem.  $Vb_2$  represents the secondary stem.  $Vb_1$  and  $Vb_2$  are also known by the other names as  $S_1$  and  $S_2$  (For the detail see verb classes).

20.  $Obj. \rightarrow NP. + Obj. S.$

For Objective suffix [Obj. S.] See 3.2.2.1.

Ex. *o:ʃn* 'Toda man (Obj.)'

*īrn* 'buffalo (Obj.)'

21.  $Soc \rightarrow NP + Soc. S.$

For Sociative suffix [Soc. S.] See 3.2.2.3.

Ex. *piʃyxe:n pody* 'with Pelikan'

*Sinmury wīʃ* 'with Sinmury'

22. Ins. —> NP + Ins. S.

For Instrumental suffix [Ins. S.] See 3.2.2.2.

Ex. <i>ana:l</i>	‘by him’
<i>nīna:l</i>	‘by you’
<i>nīnīd</i>	‘by you’
<i>ena:l</i>	‘by me’
<i>enīd</i>	‘by me’
<i>ku:xna:l</i>	‘by girl’
<i>koṇa:ṛ</i>	‘by eye’
<i>kīfya:ṛ</i>	‘by ear’
<i>po:ya:ṛ</i>	‘by mouth’
<i>moṣṭiṭ</i>	‘by axe’
<i>tu:ryiṭ</i>	‘by knife’

23. Dat. —> NP. + Dat. S.

For Dative suffix [Dat. S.] See 3.2.2.4.

Ex. <i>enk</i>	‘to me’
<i>emk</i>	‘to us’
<i>nīnk</i>	‘to you’
<i>moṛtk</i>	‘to the mund’
<i>sonk</i>	‘to people’
<i>no:yik</i>	‘to the assembly’
<i>īrk</i>	‘to buffalo’
<i>a:ṣk</i>	‘to house’

24. Abl. —> NP. + Abl. S.

For Ablative suffix [Abl.S.] See 3.2.2.5.

Ex. <i>modʒn</i>	‘from mund’
<i>u:rʒn</i>	‘from village’
<i>aʒʒn</i>	‘from that direction’
<i>kopolʒn</i>	‘from ship’

25. Purp. —> NP. + Purp.S.

For Purposive suffix [Purp.S.] See 3.2.2.8.

Ex. <i>engo:y</i>	‘for my sake’
<i>nīngo:y</i>	‘for your sake’
<i>ango:y</i>	‘for his/her sake’

26. Loc. —> NP. + Loc S.

For Locative suffix (Loc S.) See 3.2.2.7.

Ex. <i>enkīdʒ</i>	‘with me’
<i>ankīdʒ</i>	‘with him’
<i>ku:xkīdʒ</i>	‘with girl’
<i>ekaʒfotʒ</i>	‘in the evening’
<i>kaʒtalʒ</i>	‘in darkness’
<i>u:rʒ</i>	‘in the village’ (non-Toda village)

$$27. T_M \rightarrow \left\{ \begin{array}{l} [T_x] + [T_y] \\ T_z \end{array} \right\}$$

Time expression is expanded here into two components  $T_x$  and  $T_y$ .  $T_x$  stands for expression like *ku:ʒl ti:ʒ* ‘month of *ku:ʒl*’, *emoʒy ti:ʒ* ‘month of *emoʒy*’ etc.

$T_y$  stands for expressions like *ekaṛfoṭk* 'evening', *poṣol* 'midday (exactly 12 o' clock).

*ak ku:x ku:ṛl ti:ṭ pone:ḍa:n te:ti ekaṛfoṭk pi:či*

'That girl went on twelfth evening of *ku:ṛl* month (January-February)'

*aṛ pō:ṛmoṣ nala:ṇy ti:ṭ pi:či*

'That Tamil boy went in the month of Nalany'

*ma:f noṛpoṣol pi:či*

'Badaga man went at about 12 o' clock'

*kwī:f ekaṛfoṭk pi:či*

'Kota went in the evening'

$T_z$  stands for expressions like *enk muda:l* 'before me', *enk pīn* 'after me' etc.

*aə enk muda:l pi:či* 'He went before me'

*aə enk pīn pi:či* 'He went after me'

$$28. T_x \rightarrow \left\{ \begin{array}{l} T_m + T_n \\ T_1 \\ T_2 \end{array} \right\}$$

$T_x$  is expanded into  $T_m$  and  $T_n$  and  $T_1$  and  $T_2$ .

$T_m$  stands for expressions like *pīn* 'last' *iə* 'this' etc.

$T_n$  stands for expressions like *kwa:ṛ* 'year' *paṛc* 'year' *ti:ṭ* 'month' *te:ti* 'date' etc.

In Toda language there is concord between Time expressions and the verb predicate in which we find tenses. When time expressions denote past they always take past tense, the present and future will always go with the non-past (present-future) respectively.

Here  $T_1$  stands for past.

$T_2$  stands for non-past.

$T_m + T_n$  :

*Pīn parc emoḷy ti:ḷ pa:nga:n te:ti piḷy kūṣuk pozpini*

'I came on Friday the 14th of  
emoḷy month of last year for  
Lovedale mund'

29.  $T_1 \rightarrow \left\{ \begin{array}{l} \text{īne:r} \\ \text{mune:r} \end{array} \right. \left. \begin{array}{l} \text{'yesterday'} \\ \text{'day before'} \\ \text{yesterday'} \end{array} \right\}$

*tōwnīṣ īne:r pi:či* 'Tebnis went yesterday'

*sinxe:n mune:r pi:či* 'Sinkan went day before  
yesterday'

30.  $T_2 \rightarrow \left\{ \begin{array}{l} \text{īd} \\ \text{makol} \end{array} \right. \left. \begin{array}{l} \text{'to-day'} \\ \text{'to-morrow'} \end{array} \right\}$

*sinkijpu:f īd podti* 'Sinkijpuf comes to-day'

*pofīrmuṭ makol podti* 'Powermut will come  
to-morrow'

31.  $T_n \rightarrow [ T_r ] + [ T_s ]$

$T_r$  stands for expressions like *uja:fīṭ kwa:r* 'fifth year'  
and  $T_s$  stands for expressions like *ti:ḷ* 'month' *te:ti* 'date'  
etc.

$T_r$  :*pö:ɾmox e:da:fīə kwa:ɾ pi:či*

‘Tamil boy went in the second year’

 $T_m + T_r$  :*ak ku:x pīn parc pi:či*

‘that girl went last year’

 $T_m + T_r + T_s$  :*ay o:ɕ pin parc nala:ny ti:ɕ pi:či*‘that man went last year in the month of *Nala:ny*’ $T_s$  :*aə toy ti:ɕ pi:či*

‘he went in the month of toy’

32.  $T_s \rightarrow [T_t] + [T_u]$ 

$T_t$  represents expressions denoting months and this will be expanded further.  $T_u$  stands for expressions denoting week, date and names of days etc.

 $T_t$  :*nī:pa:w nala:ny ti:ɕ pi:či*

‘Nipaw went in the month of nalany’

 $T_m + T_u$  :*o:n pīnfo:ɾm pozpini*

‘I came last week’

 $T_u$  :*o:n mu:da:n te:ti pozpini*

‘I come on the third (day)’

$$T_m + T_r + T_t :$$

*o:n pīn parc toy ti:ḡ pozpini*

‘I came in the month of toy  
last year’

$$T_m + T_r + T_t + T_u :$$

*o:n pīn parc toy ti:ḡ mu:ḡa:n te:ti pozpini*

‘I came on 3rd of the month  
of tai last year’

33.  $T_u \xrightarrow{-} [T_v] + [N_{da}]$

$T_v$  stands for expressions representing week or date and  $N_{da}$  stands for the names of days like *a:sm* ‘sunday’ *tony* ‘saturday’ etc.

$$T_m + T_v :$$

*aə pīnfo:ḡm pi:či* ‘he went last week’

$$T_v :$$

*o:n a:ra:nte:ti pozpini* ‘I came on the sixth’

$$T_t + T_v :$$

*o:n ku:ḡl ti:ḡ mu:ḡa:fīḡ fo:ḡm kō:ḡk pi:špini*

‘I went for the funeral in the  
third week of the *ku:ḡl* month’

$$N_{da} :$$

*o:n o:m pozpini*

‘I came on Tuesday’

$T_r + T_t + T_v :$

*o:n a:dy ti:ř pone:da:n te:ti piřittpimik pozpini*

'I came on twelfth of *a:dy*  
month for bow - giving  
ceremony'

34.  $N_{da} \rightarrow \left\{ \begin{array}{ll} a:sm & \text{'Sunday' } \\ tu:fm & \text{'Monday' } \\ o:m & \text{'Tuesday' } \\ putufim & \text{'Wednesday' } \\ ta:m & \text{'Thursday' } \\ piřy & \text{'Friday' } \\ tony & \text{'Saturday' } \end{array} \right\}$

35.  $T_y \rightarrow [N_t] + [T_w]$

$T_y$  is expanded into  $[N_t] + [T_w]$   $N_t$  represents expressions like *poxol* 'noon, day' *ekarfofk* 'evening' etc and  $T_w$  represents expression of timings like *uj moņyk* 'at five o'clock' etc.

$T_w :$

*o:n a:rmoņyk pozpini* 'I came at 6 o'clock'

$N_t :$

*aø ekarfofk pi:ři* 'he went in the evening'

$N_t + T_w :$

*o:n ekarfofk ujmoņyk pozpini*

'I came at 5 o'clock in the  
evening'

$$N_{da} + N_t + T_w :$$

*peṭyxe:n ta:m ekaṛfoṭk ūjmoṅyk pi:či*

'Pelikan went at 5 o' clock on  
Thursday evening'

$$T_v + N_{da} + N_t + T_w :$$

*o:n toy ti:ṭ ponmu:da:n te:ti poxol pone:d moṅyk pozpini*

'I came on 12th noon at  
12 o' clock in the month of  
toy'

$$T_r + T_t + T_v + N_{da} + N_t + T_w :$$

*o:n pīn parc a:ḍy ti:ṭ ḍta:n te:ti piṭy ekaṛfoṭk no:ngmoṅyk  
pozpini*

'I came at 4 o' clock in the  
evening on Friday the 8th of  
the month of a:ḍy last year'

$$T_1 + N_t + T_w :$$

*töwbniṣ iṇe:r ekaṛfoṭk no:ng moṅyk pi:či*

'Tebnis went at 4 o' clock  
yesterday evening'

$$T_1 + N_t + T_w :$$

*mutxe:n iḍ poxol wiḍ moṅyk podti*

'Mutikan comes at 10 o' clock  
in the noon'

$$36. T_Z \rightarrow \left\{ \begin{array}{c} T_D \\ T_E \end{array} \right\}$$

$T_D$  is expanded below.  $T_E$  represents expression like *pern* 'immediately' etc.

*o:n pern podpini* 'I come immediately'

$$37. T_D \rightarrow \text{NP-K} + T_H$$

*Sinke:n enk muda:l pi:či*

'Sinkan went before me'

*o:n ank pīn pozpini* 'I came after him'

$$38. T_H \rightarrow \left\{ \begin{array}{c} T_{H_1} \\ T_{H_2} \end{array} \right\}$$

$T_{H_1}$  stands for *muda:l* 'before' and  $T_{H_2}$  stands for *pīn* 'after'

NP-K +  $T_{H_1}$  :

*aθ enk muda:l pi:či* 'he went before me'

NP-K +  $T_{H_2}$  :

*o:n ank pīn pozpini* 'I came after him'

There is concord between Time expressions and verb predicate and therefore the Time expression is classified into  $T_1$ ,  $T_2$ . When  $T_1$  occurs in a sentence, the tense of the predicate is always past and when  $T_2$  occurs, the predicate can be either in the present or in the future tense. Tense is rewritten

into past in this particular context when there is  $T_1$  and into present or future in the context when there is  $T_2$ .

39.  $[Z_1] + T_1 + [Z_2] + \text{Tense}$   
 $\rightarrow [Z_1] + T_1 + [Z_2] + \text{Past}$

Here  $Z_1$  and  $Z_2$  are abbreviations of any item or items which can occur in the respective slots. Their presence or absence does not affect the tense being rewritten into past and therefore they are put in parenthesis.

*o:n ĩne:r pozpini* 'I came yesterday'

*o:n ĩd pozpini* 'I came to-day'

[Here  $T_1$  will include 'to-day' also]

\* *Sinmury ĩne:r podti* 'Sinmury will come yesterday'

40.  $[Z_1] + T_2 + [Z_2] + \text{Tense}$   
 $\rightarrow [Z_1] + T_2 + [Z_2] + \left\{ \begin{array}{l} \text{Pers.} \\ \text{Fut.} \end{array} \right\}$

*ponap makol podti* 'Ponnap will come to-morrow'

*mutna:s makol pi:ti* 'Mutnas will go to-morrow'

*ka:wxwĩtĩ ĩd podti* 'Kawkuttan comes to-day'

*a:sxwĩtĩyfin ĩd pi:ti* 'Askulypin goes to-day'

41.  $\text{VOCI} \rightarrow \left\{ \begin{array}{l} \text{VOC} \\ \text{Intr} \end{array} \right\}$

VOCI is expanded further. VOC represents all the vocative expressions and Intr all the interjections found in Toda language.

*e:y a:nk pi:x* 'hey, go there'

*ĩyo: ayo:tĩ kō:rifiči* 'alas! that man is dead'

$$42. \text{ VOC} \rightarrow \left\{ \begin{array}{l} \text{VOC}_1 \\ \text{VOC}_2 \end{array} \right\}$$

Vocative expressions are classified into  $\text{VOC}_1$  and  $\text{VOC}_2$ .  $\text{VOC}_1$  stands for vocative forms derived from nouns. [*ku:xya:* < *ku:x*]

$\text{VOC}_1$ :

*e:y a:nk pīx* 'hey, go there'

$\text{VOC}_2$ :

*ku:xya: a:nk pī:x* 'Oh! my wife, go there'

$$43. \text{ Intr.} \rightarrow \left\{ \begin{array}{l} \text{īyo:} \quad \text{'alas!'} \\ \text{ūš} \quad \text{'exclamation of disgust'} \\ \text{tu:} \quad \text{'disgust'} \\ \dots \dots \\ \dots \dots \end{array} \right\}$$

$$44. \text{ NP} \rightarrow [\acute{\text{S}}] + \text{NP}_1$$

S is introduced here to derive the relative participle etc. This kind is very important in Dravidian languages. (See 4 12.)

$$45. \text{ NP}_1 \rightarrow \left\{ \begin{array}{l} \text{NP}_2 \\ \text{PN} \end{array} \right\}$$

$\text{NP}_1$  is further classified into pronoun [PN] and other nouns [ $\text{NP}_2$ ]. This is necessary because of the fact that  $\text{NP}_2$  alone can be preceded by any adjective or genitive and not PN.

<i>kīr mox</i>	‘small boy’
<i>etu:d as</i>	‘big house’
* <i>kin aə</i>	‘small - he’

46. NP<sub>2</sub> → [Gen] + NP<sub>3</sub>

Gen. stands for genitive case.

<i>en īr</i>	‘my buffalo’
<i>nīn a:g</i>	‘your house’
<i>aə en wīrfedn o:ē</i>	‘he is my younger sister’s husband (women’s speech)’
<i>aə en wīrfedn ku:xn mox</i>	‘he is my younger sister’s son (women’s speech)’
<i>aə en o:ēŋ dan okn o:ē</i>	‘he is my husband’s elder sister’s husband (women’s speech)’

## 47. Gen → NP + Gen.S.

For Genitive case suffix See 3.2.2.6.

<i>en īr</i>	‘my buffalo’
<i>an mox</i>	‘his son’

48. NP<sub>3</sub> → [Dem] + NP<sub>4</sub>

Demonstrative adjectives occur before the nouns other than pronouns [PN] and quantitative nouns [N<sub>quan</sub>]. Dem. stands for demonstrative adjectives like *ay* ‘that’ *iy* ‘this’, *a* ‘that’, *i* ‘this’ etc.

<i>a mod</i>	'that Toda village'
<i>a twī:</i>	'that pen'
<i>a tōw</i>	'that God'
<i>i no:r</i>	'this sacred place'
<i>ay īr</i>	'that buffalo'
<i>ay u:r</i>	'that Tamil village'
<i>iy īr</i>	'this buffalo'
<i>iy u:r</i>	'this Tamil village'

$$49. \text{NP}_4 \rightarrow \left\{ \begin{array}{l} \text{Num.} \\ \text{Ord.} \\ \text{M. Adj.} \\ \text{Ind.} \end{array} \right\} + \text{NP}_5$$

$\text{NP}_4$  is expanded into numeral adjective [Num], ordinal adjective [Ord] and Mass adjective [M. Adj.] and they can be followed by another noun phrase [ $\text{NP}_5$ ].

Num. +  $\text{NP}_5$  :

*ūj o:t* 'five Toda men'

Ord. +  $\text{NP}_5$  :

*no:nga:fīθ ku:x* 'fourth daughter'

*ōta:n te:ti* 'eighth day'

Dem. + Num. +  $\text{NP}_5$  :

*ay ūj a:gm* 'those five houses'

Ind. :

*upum o:t* 'many persons'

*ity īr* 'few buffaloes'

50. Ord.  $\rightarrow$  Num. + Ord<sub>s</sub> :

Ord<sub>s</sub> represents the ordinal suffixes *a:fīθ* and *a:n*.

*no:ng-a:fīθ a:s* 'fourth house'

*pone:d-a:n te:ti* 'twelfth day'

51. Tr  $\rightarrow$  Ord +  $\left\{ \begin{array}{l} kwa:r \\ parc \end{array} \right\}$

*o:n mu:da:fīθ kwa:rʂ pozpini*

'I came in the third year'

52. T<sub>t</sub>  $\rightarrow$   $\left\{ \begin{array}{l} \text{Ord}_d \\ N_{\text{mon}} \end{array} \right\} + ti:ʂ$

T<sub>t</sub> is expanded here. Ord<sub>d</sub> stands for ordinals denoting one to twelve and N<sub>mon</sub> stands for names of twelve months.

*e:da:fīθ ti:ʂ* 'second month'

*o:n a:dy ti:ʂ podpini* 'I will come in the month of *a:dy*'

*a pō:rmox a:əry ti:ʂ pi:či*

'that Tamil boy went in the month of *a:əry* (April-May)'

*ma:fmox ku:rl ti:ʂ pi:či*

'Badaga boy went in the month of *ku:rl*'

$$53. T_v \rightarrow \left\{ \begin{array}{l} \text{Ord}_p + \text{po:ɽm} \\ \text{Ord}_t + \text{te:ti} \end{array} \right\}$$

$\text{Ord}_p$  stands for ordinals denoting one to four and  $\text{Ord}_t$  stands for ordinals denoting one to thirty one.

*e:da fɿə po:ɽm* 'second week'  
*pa.nga:n te:ti* 'fourteenth day'

$$54. N_t \rightarrow \left\{ \begin{array}{l} \text{i:sy} \quad \text{'morning' } \\ \text{poxol} \quad \text{'noon' } \\ \text{ekarfoik} \quad \text{'evening' } \\ \dots\dots\dots \\ \dots\dots\dots \end{array} \right\}$$

$$55. T_w \rightarrow \text{Num}_m + \left( \left\{ \begin{array}{l} \text{ko:l} \\ \text{ar} \\ \text{muko:l} \end{array} \right\} \right) + \text{mɔnyk}$$

$\text{Num}_m$  stands for the numerals one to twelve.

*mu:ɔ̄ mɔnyk* 'at 3 o' clock'  
*mu:ɔ̄ ko:l mɔnyk* 'at 3-15'  
*no:ng mɔnyk* 'at 4 o' clock'  
*no:ng ar mɔnyk* 'at 4-30'  
*üj muko:l mɔnyk* 'at 5-45'

$$56. \text{Ord}_d \rightarrow \text{Num}_m + \text{Ord}_s$$

$\text{Ord}_d$  stands for all ordinals which occur with the names of months, that is one to twelve.

*e:da:fɿə ti:ɕ* 'second month'  
*öɽa:fɿə ti:ɕ* 'eighth month'

57.  $\text{Ord}_t \rightarrow \text{Num}_t + \text{Ord}_s$

$\text{Ord}_t$  represents all numerals from one to thirty one which can occur before the noun *te:ti* 'day or date'

*ōta:n te:ti* 'eighth day'

58.  $\text{Ord}_p \rightarrow \text{Num}_p + \text{Ord}_s$

$\text{Num}_p$  represents numerals one to four.

*e:da:fīθ po:ɾm* 'second week'

*mu:da:fīθ po:ɾm* 'third week'

*no:nga:fīθ po:ɾm* 'fourth week'

59.  $\text{N}_{\text{mon}} \rightarrow$ 

<i>ku:ɾl</i>	Dec. - Jan.
<i>ala:ny.</i>	Jan. - Feb.
<i>nala'ny</i>	Feb. - Mar.
<i>a:ny</i>	Mar. - Apr.
<i>a:ery</i>	Apr. - May
<i>a:dy</i>	May - Jun.
<i>a:fny</i>	Jun. - Jul.
<i>perta:əy</i>	Jul. - Aug.
<i>tuðəĩfy</i>	Aug. - Sep.
<i>kīrdīfy</i>	Sep. - Oct.
<i>toy</i>	Oct. - Nov.
<i>emoɾy</i>	Nov. - Dec.

60.  $\text{M. Adj} \rightarrow \text{M. Adj}_1$

$\text{M. Adj}_1$  represents expressions like

*mu:d e:ker neln* 'land of three acres'

*ūj ačok po:s* 'milk of five seer'

*wīd pi:čm kapoɾy* 'jaggery of one vi:če'

61.  $M. Adj_1 \rightarrow Num + MLW$

MLW stands for names of measures, length and weights.

62.  $MLW \rightarrow \left\{ \begin{array}{l} M \\ L \\ W \end{array} \right\} \begin{array}{l} /- N_m \\ /- N_l \\ /- N_w \end{array}$

This rule is a context-sensitive rule. MLW is expanded into names of measure [M] like *ak*, *kwa:x*, names of length measure [L] like *oŷy*, *e:ker*, *magoy* etc., and names of weights [w] like *pičm*, *moŷuf* etc.

63.  $M \rightarrow \left\{ \begin{array}{l} ak \\ kwa:x \\ \dots\dots \\ \dots\dots \end{array} \right\}$

*wī:r ak po:š*

'milk of one *ačok* measure'

*e:đ kwa:x potm*

'ragi of two big *ačok* measure'

64.  $L \rightarrow \left\{ \begin{array}{l} e:ker \\ oŷy \\ magoy \\ \dots\dots \\ \dots\dots \end{array} \right\}$

*e:đ e:ker pu:my*

'land of two acres'

*pot oŷy poeky*

'ten feet distance'

*üj magoy pu:txužy*

'*pu:txužy* of five *magoy* measure'

$$65. \quad W \longrightarrow \left\{ \begin{array}{l} pi:\check{c}m \\ mo\eta uf \\ \dots\dots\dots \\ \dots\dots\dots \end{array} \right\}$$

- no:ng pi:\check{c}m kapo\eta y*      'jaggery of four *vi:\check{c}e*'  
*\u0177j pi:\check{c}m mo:f*      'flour of five *vi:\check{c}e*'  
*w\u0177d mo\eta uf kapo\eta y*      'jaggery of one *ma\eta unku* weight'

$$66. \quad \text{Ind.} \longrightarrow \left\{ \begin{array}{l} upum \text{ 'many' } \\ ity \text{ 'few' } \end{array} \right\}$$

- upum \u0177r*      'many buffaloes'  
*ity o:\check{c}*      'few persons'

$$67. \quad NP_5 \longrightarrow [N_q] + NP_6$$

$N_q$  stands for nouns of quality

- na\u0161 ku:\bar{x}*      'beautiful girl'  
*w\u0177\u0177y p\u00f4lk*      'good lamp'  
*w\u0177\u0177y \u0177r*      'good buffalo'  
*w\u0177\u0177y mox*      'good boy'

$$68. \quad NP_6 \longrightarrow [\text{Adj}] + NP_7$$

Adjective [Adj] stands for expressions like *etu:d* 'big', *k\u0177r* 'small' etc.

- etu:d mo\check{d}*      'big Toda village'  
*etu:d a:\check{s}*      'big house'  
*k\u0177r mox*      'small boy'

$$69 \text{ Adj} \rightarrow \left\{ \begin{array}{l} \text{Adj}_a \\ \text{Adj}_p \end{array} \right\}$$

Adjective is expanded here as  $\text{Adj}_a$  and  $\text{Adj}_p$ .  $\text{Adj}_a$  stands for adjectives like *etu:d* 'big' *kīr* 'small' *pa:fn* 'old' etc.  $\text{Adj}_p$  stands for adjectives like *pöḥ* 'white', *po:x* 'red', *ni:lm* 'blue', and *poč* 'green' etc.

$$70. \text{Adj}_a \rightarrow \left\{ \begin{array}{l} \textit{etu:d} \\ \textit{kīr} \\ \textit{wīḥy} \\ \textit{pa:fn} \\ \textit{.....} \\ \textit{.....} \end{array} \right\}$$

<i>etu:dīr</i>	'big buffalo'
<i>etu:d o:ḥ</i>	'big man'
<i>etu:d a:s</i>	'big house'
<i>kīr mox</i>	'small boy'
<i>pa:fn toṛp</i>	'old dhoti'
<i>pa:fn pu:txuḥy</i>	'old cloak'

$$71. \text{Adj}_p \rightarrow \left\{ \begin{array}{l} \textit{ka:r} \\ \textit{pöḥ} \\ \textit{ni:lm} \\ \textit{po:x} \\ \textit{poč} \\ \textit{.....} \\ \textit{.....} \end{array} \right\}$$

<i>pöḥ toṛp</i>	'white dhoti'
<i>pöḥ kopañ</i>	'white butterfly'
<i>ni:lm kal</i>	'blue stone (in the ring)'
<i>poč pul</i>	'green grass'

72.  $NP_7 \rightarrow [N. Adj_q] + NP$

$N.Adj_q$  stands for any noun occurring as an attribute to another noun.

<i>kō:r a:s</i>	'death house'
<i>pīš a:s</i>	'hut to which woman goes after child birth and stays until new moon'

73.  $Num \rightarrow \left\{ \begin{array}{l} Num_s \\ Num_p \end{array} \right\}$

Numeral is classified into numeral singular [ $Num_s$ ] and numeral plural [ $Num_p$ ].

74.  $Num_s \rightarrow \left\{ \begin{array}{l} Num_c \\ Frac \end{array} \right\}$

Singular number is expanded into singular cardinal [ $Num_c$ ] like *wīd* 'one' and fraction [Frac.] like *ko:l* 'quarter', *ar* 'half', *mu:kol* 'three fourths', etc.

75.  $Num_p \rightarrow Num_{pc} + [Frac.]$

$Num_{pc}$  represents plural cardinal numbers like *mu:d* 'three', *ūj* 'five', *pot* 'ten' etc.

$Num_{pc} + Frac.$

<i>mu:d kol</i>	' $3\frac{1}{2}$ '
<i>e:d ar</i>	' $2\frac{1}{2}$ '
<i>no:ng muko:l</i>	' $4\frac{3}{4}$ '

$$76. \text{Frac} \rightarrow \left\{ \begin{array}{ll} ko:l & \text{'quarter' } \\ ar & \text{'half' } \\ muko:l & \text{'three fourths' } \end{array} \right\}$$

$$77. \text{N} \rightarrow \left\{ \begin{array}{l} N_A \\ N_{IA} \end{array} \right\}$$

Nouns can be divided into animate nouns  $[N_A]$  and inanimate nouns  $[N_{IA}]$ <sup>1</sup>

*ankīḍṣ upum īr wīḍy* 'he has more buffaloes'

*enkīḍṣ upum poṇm wīḍy* 'I have more money'

*īrkīḍṣ upum kwar wīḍy* 'there is mud near buffalo'

*me:ntṣ upum pum wīḍy* 'there are plenty of fruits in the tree'

*pa:fyš ni:r o:roy* 'There is no water in the well'

$$78. N_A \rightarrow \left\{ \begin{array}{l} N_{pn} \\ N_{cn} \end{array} \right\}$$

$N_{pn}$  represents proper nouns  $[N_{pn}]$  and  $N_{cn}$  represents common noun  $[N_{cn}]$ . The proper nouns do not take plural suffix and common nouns can take the plural suffix.

1 This classification is necessitated due to the following reasons. Certain nouns take *kīḍṣ* as locative case sign and certain others do not. Those which take *kīḍṣ* are classified here as animate and the rest inanimate. Eventhough human and non-human distinctions are maintained in interrogative pronouns [*o:ry* 'who' in 'what' *e:ə* 'which'] we can't find the distinction in syntactic level.

$N_{pn}$  :

*töwbnĩş* 'a personal name'

*işköxwĩ!ŋ* 'a personal name'

*mu:nbo:wxwĩ!ŋ* 'a personal name'

$N_{cn}$  :

*wĩŋfed* 'younger brother'

*mox* 'boy'

*ku:x* 'girl'

79.  $N_{pn} \rightarrow \left\{ \begin{array}{l} N_{pm} \\ N_{pf} \end{array} \right\}$

Proper nouns are classified into masculine proper nouns [ $N_{pm}$ ] and feminine proper nouns [ $N_{pf}$ ].

$N_{pm}$  :

*aŋpa:wnĩş* 'a personal name'

*a:şxwĩŋyŋĩn* „

*pĩnsfĩn* „

$N_{pf}$  :

*pofĩrmuŋ* 'a personal name'

*eŋcigyfu:f* „

*sinbüdy* „

80.  $N_{cn} \rightarrow N_{cns} + [P_1]$

$N_{cns}$  :

*mox* 'boy'

*ku:x* 'girl'

$N_{cn} + Pl_1$  :

*mox - a:m* 'boys'

*ku:x - a:m* 'girls'

*kwī:f - a:m* 'Kotas'

81.  $N_{cns} \rightarrow \left\{ \begin{array}{l} N_{cn_I} \\ N_{cn_D} \end{array} \right\}$

$N_{cn_I}$  stands for inherent nouns like *wīrfed* 'younger brother' *eyi*; 'father' *af* 'mother' etc.  $N_{cn_D}$  stands for derived nouns like *kel-o:ž* 'old man' *kel-oč* 'old woman' etc.

$N_{cn_I}$  has no morphological marker for the gender number whereas  $N_{cn_D}$  has morphological marker.

82.  $N_{cn_I} \rightarrow \left\{ \begin{array}{l} N_{cn_m} \\ N_{cn_f} \end{array} \right\}$

Inherent common nouns are expanded into masculine common noun  $[N_{cn_m}]$  and feminine common noun  $[N_{cn_f}]$ .

$$83. N_{cn} \cdot D \rightarrow N_{cn} B + G.N.$$

$N_{cn} B$  stands for common noun base and G.N. for gender-number suffixes.

*kel- o:t* 'old man'

*kel- oč* 'old woman'

$$84. G. N. \rightarrow \left\{ \begin{array}{l} \text{mas.} \\ \text{fem.} \end{array} \right\}$$

$$85. N_{IA} \rightarrow \left\{ \begin{array}{l} N_{cn} \\ N_{ncn} \end{array} \right\}$$

Inanimate nouns [ $N_{IA}$ ] are classified into count nouns [ $N_{cn}$ ] and non-count nouns [ $N_{ncn}$ ]

$$86. N_{ncn} \rightarrow \left\{ \begin{array}{l} N_{ma} \\ N_{pn} \end{array} \right\}$$

$N_{ma}$  represents the mass noun like *epo:y* 'oil' *ni:r* 'water' etc. and  $N_{pn}$  represents the proper nouns (names of the place) like *pojo:rm* 'Ootacamund', *mi:tpa:w* 'Mettupalayam', *maəra:č* 'Madras', *moysu:r* 'Mysore' etc.

Mass noun cannot take plural suffix while count noun can take plural suffix.

$$87. N_{ma} \rightarrow \left\{ \begin{array}{l} N_{ql} \\ N_{qn} \end{array} \right\}$$

Mass noun is further sub-divided into quality noun [ $N_{ql}$ ] like *sinm* 'anger with grudge', *püty* 'wisdom', and *pöť* 'white' etc and nouns of quantity [ $N_{qn}$ ] like *nīy* 'ghee', *kapoty* 'jaggery', *neš* 'paddy' etc. Quantity noun can take mass adjective like names of weights and measures.

$$88. N_{qn} \rightarrow \left\{ \begin{array}{c} N_M \\ N_L \\ N_W \end{array} \right\}$$

$N_M$  stands for nouns which can be preceded by nouns of measurements,  $N_L$  for nouns which can be preceded by nouns of length and  $N_W$  for nouns which can be preceded by nouns of weights.

M +  $N_M$  :

*a:ř ak nīy* 'ghee of six *ačok* measure'

L +  $N_L$  :

*üj e:ker pu:my* 'land of five acres'

W +  $N_W$  :

*öť pi:čm kapoty* 'jaggery of eight *vi:če*'

$$89. N_{ql} \rightarrow \left\{ \begin{array}{ll} *naš* & \text{'beauty'} \\ *sinm* & \text{'anger with grudge'} \\ *poč* & \text{'green'} \\ *nī:lm* & \text{'blue'} \\ \dots\dots\dots & \\ \dots\dots\dots & \end{array} \right\}$$

90.  $N_M \rightarrow$ 

<i>ašky</i>	‘rice’
<i>nīy</i>	‘ghee’
<i>epo:y</i>	‘oil’
<i>po:ḡ</i>	‘milk’
.....	
.....	

91.  $N_L \rightarrow$ 

<i>neln</i>	‘land’
<i>poeky</i>	‘distance’
<i>torp</i>	‘dhoti’
<i>pu:txuḡy</i>	‘cloak’
<i>ko:ṛ</i>	‘cultivable land’
.....	
.....	

92.  $N_W \rightarrow$ 

<i>pūly</i>	‘tamarind’
<i>kapoty</i>	‘jaggery’
<i>arsn</i>	‘turmeric’
.....	
.....	

93.  $N_{cn} \rightarrow N_{cns} + [Pl]$

Count noun may be of singular and plural

$N_{cns}$  :

<i>kaḡ</i>	‘stone’
<i>me:ṇ</i>	‘tree’
<i>pu:f</i>	‘flower’
<i>kīḡf</i>	‘shrub’

$N_{cn} + [Pl] :$

<i>kag-a:m</i>	'stones'
<i>me:ṅ-a:m</i>	'trees'
<i>pu:f-a:m</i>	'flowers'
<i>kīḍf-a:m</i>	'shrubs'

94.  $PN \rightarrow \left\{ \begin{array}{l} PPN \\ DPN \end{array} \right\}$

PPN stands for personal pronouns which have number distinction and DPN for demonstrative pronouns which do not have gender distinction.

PPN :

<i>o:n</i>	'I'
<i>om</i>	'we (incl.)'
<i>em</i>	'we (excl.)'
<i>nī:</i>	'you (sg.)'
<i>nīm</i>	'you (pl.)'

DPN :

<i>aθ</i>	'he / she / it - that'
<i>iθ</i>	'he / she / it - this'

95.  $PPN \rightarrow \left\{ \begin{array}{l} PPN_1 \\ PPN_2 \end{array} \right\} + Nu$

There are two kinds of personal pronouns, first person [ $PPN_1$ ], second person [ $PPN_2$ ] and Nu. stands for number suffixes.

$$96. \text{DPN} \rightarrow \left\{ \left\{ \begin{array}{l} \text{RDPN} \\ \text{PDPN} \end{array} \right\} + \text{person} + \text{number} \right\}$$

Demonstrative pronouns are divided into remote demonstrative pronoun [RDPN] and proximate pronoun [PDPN].

RDPN :

<i>a-ə</i>	'he / she / it - that'
<i>a-ə-a:m</i>	'they'

PDPN :

<i>i-ə</i>	'he/she/it-this'
<i>i-ə-a:m</i>	'they'

$$97. \text{Vd} \rightarrow \left\{ \begin{array}{l} \text{Vd}_p \\ \text{Vd}_n \end{array} \right\}$$

$\text{Vd}_p$  stands for defective positive verb and  $\text{Vd}_n$  stands for defective negative verb.

$\text{Vd}_p$  :

<i>aə enk pe:kīyi</i>	'I want it'
-----------------------	-------------

$\text{Vd}_n$  :

<i>aə enk kwīīyi</i>	'I don't want that'
----------------------	---------------------

$$98. \text{Cl} \rightarrow \left\{ \begin{array}{l} [\text{Cl}_1] [\text{Cl}_2] \\ \text{Cl}_3 \end{array} \right\}$$

Clitics  $\text{Cl}_1$  may be followed by  $\text{Cl}_2$ .

N + Cl<sub>1</sub> + VP :

*aθ-m pi:či* 'he also went'

N + Cl<sub>2</sub> + VP :

*aθ-to:n pi:či* 'he went'

N + Cl<sub>1</sub> + Cl<sub>2</sub> + VP :

*aθ-m to:n pi:či* 'he also went'

N + Cl<sub>3</sub> + VP :

*makolkem pī:k :* 'go atleast to-morrow'

99. Cl<sub>1</sub> —> *m*

100. Cl<sub>2</sub> —> *to:n*

101. Cl<sub>3</sub> —> *e:n*

For their further classification see section VI.

102. Part —> { *pīn* 'afterwards' }  
 { *mařč* 'again' }  
 { *me:l* 'above' }  
 { *ki:l* 'below' }  
 { *ułg* 'inside' }  
 { ..... }  
 { ..... }

For their further classification see section VII.

## 9.2. Grammatical transformation

### 9.2.1. Relative participle

Toda as other Dravidian languages has a category called relative participle which is used to form a kind of construction

corresponding to English relative clause. Relative participle has the characteristics of verb and adjective. It is partly a verb because it has temporal reference and partly an adjective since it qualifies a noun. There are three kinds of relative participles in Toda, 1. Past relative participle, 2 Present-future relative participle and 3. Negative relative participle.

Relative participle is always in construction with the following noun.

<i>a:nk</i>	<i>podfoj</i>	<i>o:ʧa:m</i>
1	2	3

Here *pod-ø-foj* 'came' (adj.) is the relative participle and it is in construction with *o:ʧa:m* 'persons' *foj* is the participle marker which follows the tense marker - *ø*.

Relative participle in Toda always precedes the noun which it qualifies.

*podfoj o:ʧa:m* 'the persons who came'. But in English the relative clause follows the noun as in

'persons who came'

It is found that the relative participle has different grammatical relationships with the noun that follows.

1. Subject-predicate relationship

*podfoj o:ʧa:m*      'persons who came'

2. Object-predicate relationship

*öšʧfoj poŋy*      'the work which (someone)  
said'

## 3. Instrumental-predicate relationship

*kwartfoj mošt* 'the axe with which (someone)  
cut'

## 4. Dative-predicate relationship

*mo:rfoj ko:s* 'the money to which (someone)  
sold'

## 5. Locative-predicate relationship

*pi:t o:lɑ:r* 'the path in which (someone)  
goes'

## 6. Purposive-predicate relationship

*uđt ni:r* 'the water that is used for  
drinking'

## 9.2 1.1. Subject-predicate relationship

When the head of the noun phrase is the same as the subject of the sentence we find that the same relationship (Subject-predicate) in the phrase also. In the following sentence Relative participle (2) and noun (3) show the subject-predicate relation.

1. *o:n podt o:ξη kozpini*  
1 2 3 4

'I saw the man who comes'

This sentence is derived when the constituent sentence

2. *o:ξη podti*  
1 2

'the man comes'

is embedded into the matrix sentence

3.  $\acute{o}:n$   $o:\xi\eta$   $ko\zeta pini$   
       1      2      3  
 'I saw the man'

Note that when the constituent sentence is embedded into the noun phrase—we find two identical nouns one in the constituent and another in the matrix and the resultant sentence undergoes many transformations we get the resultant sentence,

$o:n$  [ $o:\xi$   $podti$ ]  $o:\xi\eta$   $ko\zeta pini$

(The constituent sentence is within parentheses) and this undergoes the following transformational rules.

Relativization transformation

SD:  $o:n$   $o:\xi$   $podti$   $o:\xi\eta$   $ko\zeta pini$   
       1      2      3      4 5      6  
       NP NP VP NP Obj.S. VP

SC:  $1+2+3+4+5+6 \Rightarrow 1+2+3-R.P.+4+5+6.$

Equi NP deletion transformation

SD: NP+NP+VP—R.P.+NP+Obj.S.+VP  
       1 2 3 4 5 6

SC:  $1+2+3-R.P.+4+5+6 \Rightarrow 1+3+4+5+6$   
       if  $2=4$

(Since  $2=4$ , 2 is deleted)

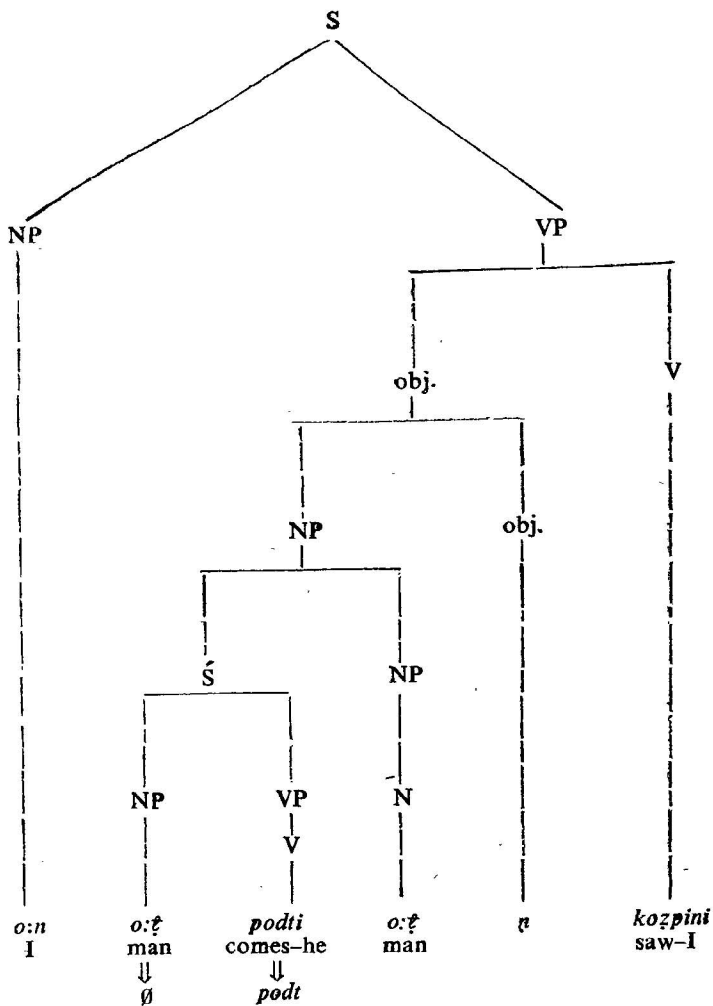

## 9.2.1.2. Object-predicate relationship

When the head of the noun phrase is the same as the object of the sentence we find the same relation (object – predicate) in the phrase also. In the following sentence Relative participle (3) and noun (4) show the object – predicate relation.

4. *o:n nīm öšt kelcn kīspini*  
 1 2 3 4 5  
 ‘I shall do the work which you say’

This sentence is derived when the constituent sentence,

5. *nīm kelc öštīši*  
 1 2 3  
 ‘you say the work’

is embedded into the NP of the matrix sentence

6. *o:n kelcn kīspini*  
 1 2 3  
 ‘I do the work’

we get,

- o:n [ nīm kelc öštīši ] kelc n kīspini*  
 NP [ NP NP VP ] NP Obj.S VP

[The constituent sentence is within parentheses] and this undergoes the following transformational rules.

Relativization transformation

- SD: *o:n nīm kelc öštīši kelc n kīspini*  
 1 2 3 4 5 6 7  
 NP NP NP VP NP Obj.S. VP

- SC:  $1+2+3+4+5+6+7 \Rightarrow 1+2+3+4\text{-R.P.}+5+6+7$

## Equi NP deletion transformation

SD : NP+NP+NP+VP-R.P.+NP+Obj.S.+VP  
 1 2 3 4 5 6 7

SC : 1+2+3+4-R.P.+5+6+7  $\Rightarrow$  1+2+4+5+6+7  
 If 3=5

[Since 3=5, 3 is deleted.]

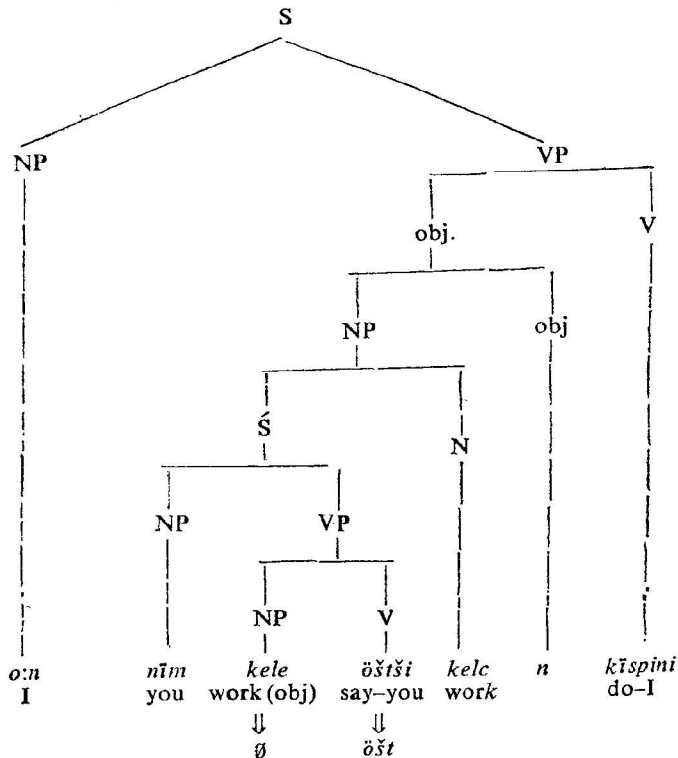

## 9.2.1.3. Instrumental-predicate relationship

When the head of the noun phrase is the same as the instrument of the sentence we find that the same relation (Inst.-predicate) in the phrase also. In the following sentence, Relative participle (2) and noun (3) show the instrumental-predicate relation.

7. *o:n kwartfoj mošt uęš wīdy*  
 1        2        3        4        5  
 'the axe with which I cut is inside'

This sentence is derived when the constituent sentence,

8. *o:n moštīť kwaršpini*  
 1        2        3  
 'I cut with an axe'  
 1        3        2

is embedded into the NP of matrix sentence

9. *mošt uęš wīdy*  
 1        2        3  
 'the axe is inside'  
 1        3        2

we get,

- [*o:n moštīť kwaršpini*] *mošt uęš wīdy*  
 NP    NP        VP        NP    Adv.    VP

(The constituent sentence is within parentheses) and this undergoes the following transformational rules.

Relativization transformation rule

- SD: *o:n moštīť kwaršpini mošt uęš wīdy*  
 NP    NP        VP        NP    Adv.    VP  
 1        2        3        4        5        6

- SC: 1+2+3+4+5+6 ⇒ 1+2+3-R.P.+4+5+6

## Equi NP deletion transformation rule

SD: NP+NP+VP-R.P.+NP+Adv.+VP  
 1 2 3 4 5 6

SC: 1+2+3-R.P+4+5+6  $\Rightarrow$  1+3+4+5+6  
 If 2=4

(Since 2=4, 2 is deleted)

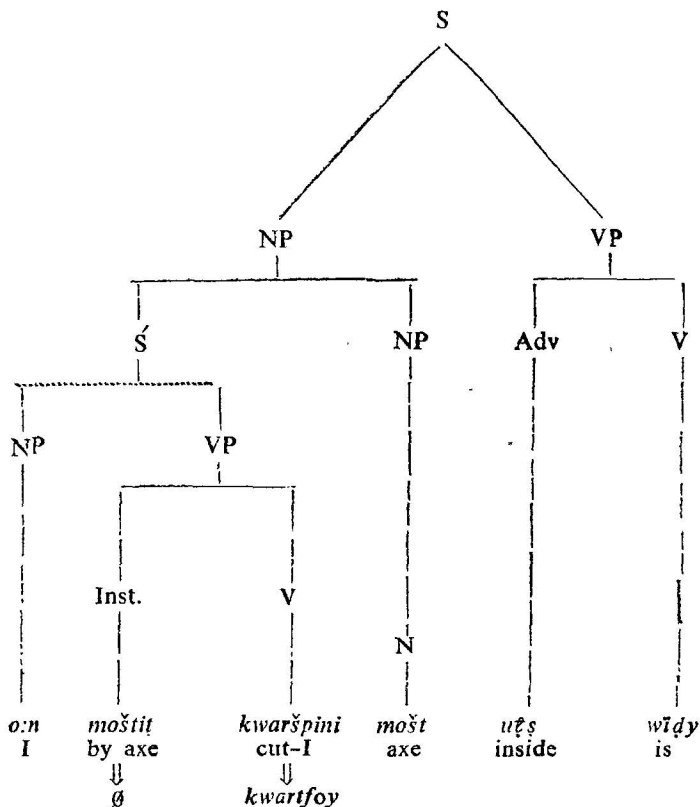

## 9.2.1.4. Dative predicate relationship

When the head of the noun phrase is the same as the dative of the sentence we find that the same relation (Dative predicate) in the phrase also. In the following sentence Relative participle (3) and noun (4) show the dative-predicate relationship.

10. *ni: ki:č mo:ryfoj ko:sn e:spi*

1      2            3            4      5

'you (sg.) took the money to which you sold the

1            5            4                    1      3

potato

2

This sentence is derived when the constituent sentence,

11. *ni: ko:sk ki:č mo:ršpi*

1      2      3      4

'you sold potato for money'

is embedded into the matrix sentence

12. *ni: ko:sn e:spi*

1      2      3

'you took money'

we get,

*ni: [ni: ko:sk ki:č mo:ršpi] ko:s n e:spi*

NP   NP   Dat.   NP      VP      NP   Obj.S.   VP

1      2      3      4            5            6      7      8

(the constituent sentence is within parentheses) and this undergoes the following transformational rules.

## Relativization transformation rule

SD: *ni: ni: ko:sk ki:č mo:žšpi k:os n e:spi*  
 NP NP Dat. NP VP NP Obj.S. VP  
 1 2 3 4 5 6 7 8

SC:  $1 + 2 + 3 + 4 + 5 + 6 + 7 + 8 \Rightarrow$   
 $1 + 2 + 3 + 4 + 5\text{-R.P.} + 6 + 7 + 8$

## Equi NP deletion transformation rule

SD: NP + NP + Dat. + NP + VP - R.P. + NP + Obj.S. + VP  
 1 2 3 4 5 6 7 8

SC:  $1 + 2 + 3 + 4 + 5\text{-R.P.} + 6 + 7 + 8 \Rightarrow$   
 $1 + 4 + 5 + 6 + 7 + 8$   
 if  $1=2$  and  $3=6$

(Since  $1=2$ , 2 is deleted and  $3=6$ , 3 is deleted)

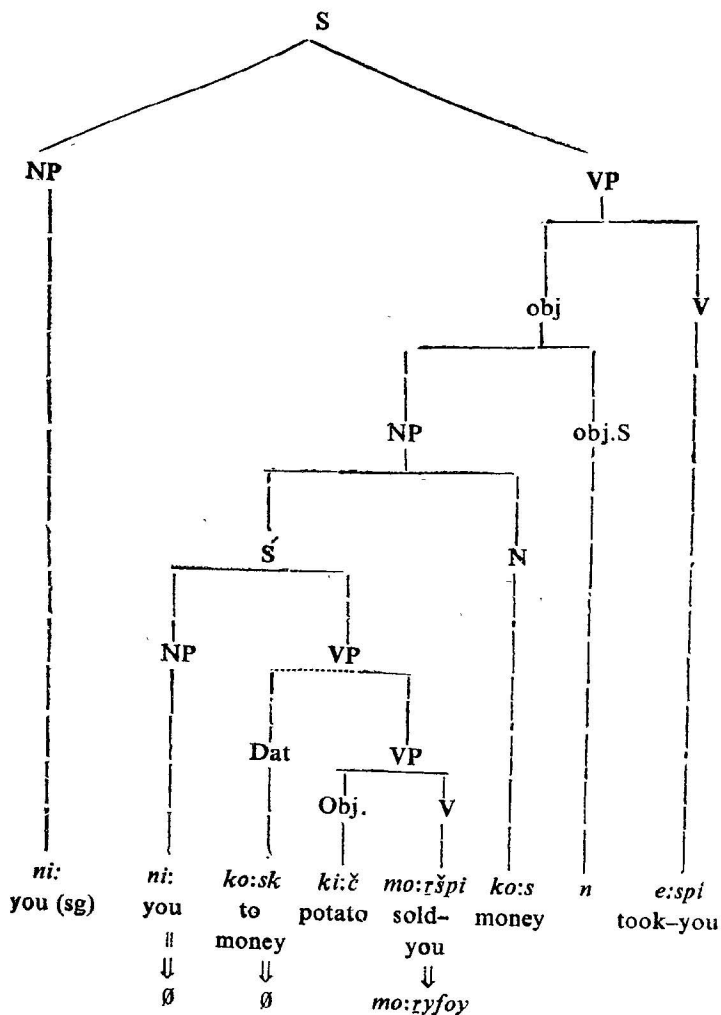

## 9.2.1.5. Locative-predicate relationship

When the head of the noun phrase is the same as the locative of the sentence we find that the same relation (loc.-predicate) in the phrase also. In the following sentence, Relative participle (3) and noun (4) show the locative-predicate relation.

16. *iθ wīḡo:ḡ pī:t o:ḡa:r*  
 1        2        3        4

'this (is) the path in which priest goes'

1                      4                      2        3

This sentence is derived when the constituent sentence

17. *wīḡo:ḡ o:ḡa:rḡ pī:ti*  
 1        2        3

'priest goes in the path'

1        3        2

is embedded into the matrix sentence

18. *iθ o:ḡa:r īyi*  
 1        2        3

'This is the path'

1        3        2

we get,

*iθ [wīḡo:ḡ o:ḡa:rḡ pī:ti] o:ḡa:r*  
 NP    NP    NP-Loc.    YP    NP  
 1        2        3        4        5

(the constituent sentence is within parentheses) and this undergoes the following transformational rules.



## 9.2.1 6. Purposive-predicate relationship

When the head of the noun phrase is the same as the purposive of the sentence we find that the same relation (Purp. - predicate) in the phrase also. In the following sentence Relative participle (2) and noun (3) show the purposive - predicate relation.

<i>iə</i>	<i>uđt</i>	<i>ni:r</i>	
1	2	3	
this (is) drinking water'			
1	2	3	

No transformational rule is applied in phrase marker (3). Embed this in the base phrase marker (2) in the place of  $\bar{S}$ , by a generalised substitution transformation  $T_E$  and the phrase marker *ni:r* 'water' *em* 'we' *ni:r uđpumi/uđkum* 'will drink-we' *aəgo:y to:n* 'for that purpose' *wīđy* 'is' obtained. To this apply the purposive transformation  $T_{purp}$ , so as to enable to get the expression *uđfīđtgo:yto:n* 'for the purpose of drinking'. Now we get the phrase marker *ni:r* 'water' *em* 'we' *uđfīđtgo:yto:n* 'for drinking' *wīđy* 'is' which will be embedded in turn in the base phrase marker (1) in the place of  $\bar{S}$  by  $T_E$ . The resultant phrase marker is *ni:r* 'water' *em* 'we', *ni:r* 'water' *uđfīđtgo:yto:n* 'for the purpose of drinking' *wīđy* 'is' *iə*, this-it' *ni:r* 'water' is obtained.

When we apply the relativization transformation  $T_E$  to this phrase marker *ni:r* 'water' *em* 'we' *uđfīđtgo:yto:n* 'for the purpose of drinking' *wīđt* 'is (adj)' *ni:r* 'water' *iə* 'this-it', *ni:r* 'water' is obtained.

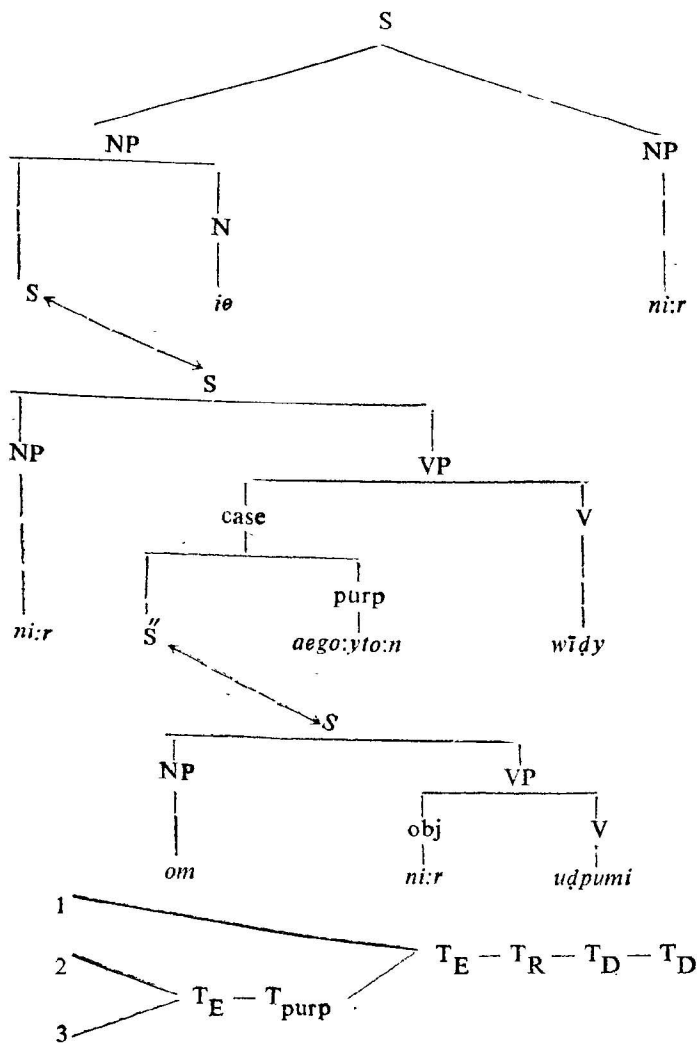

To this deletion transformation  $T_D$  is applied and the repeated NP *ni:r* 'water' *em* 'we (excl.)' are deleted.

The resultant phrase marker is *uđfīđtgo:yto:n* 'for drinking' *wīđt* 'is (adj.)' *ni:r* 'water' *iə* 'this-it' is obtained. In order to get *uđt ni:r* 'drinking water' again  $T_D$ , the deletion transformation is applied. The resultant phrase marker *uđt* 'drinking' *ni:r* 'water' *iə* 'this-it'

By the permutation rule,

<i>uđt</i>	<i>ni:r</i>	<i>iə</i>	
drinking	water	this-it	
1	2	3	⇒
<i>iə</i>	<i>uđt</i>	<i>ni:r</i>	
'this-it drinking water'			
3	+	1	+
		2	

which bring 1 between 3 and 2 and we get,

<i>iə</i>	<i>uđt</i>	<i>ni:r</i>	
1	2	3	
'this (is) drinking water'			
1	2	3	

### 9.2.2. Relative participle plus particle

Relative participle can also be in construction with certain participle and the whole phrase modifies the verb phrase. In the following sentence,

<i>o:n</i>	<i>aə</i>	<i>əštfoy</i>	<i>mo:tiry</i>	<i>kīspini</i>
1	2	3	4	5
'I did as he said'				

*öšt-g-foy* is the relative participle and *mo:tiry* 'that way' is the particle and the phrase *öštfoy mo:tiry* is in construction with the following verb *kĩspini* 'did - I'. The tense of the relative participle is conditioned by the particle occurring in the embedding sentence. The finite verb of the constituent sentence is followed by *mo:tiry* 'that way'. The verb phrase is modified when the participle *mo:tiry* follows it. Only a few particles alone can occur with past relative participle.

Particle set up in the matrix	gloss	forms set up in the matrix	Occurrence
<i>mo:tiry</i>	'that way'	<i>mo:tiry</i>	Past R.P.

#### 9.2.2.1. Relative participle + particle

*a mo:tiry* 'in that way'

*a mo:tiry* 'in that way' occurs after past relative participle. The finite verb is converted into relative participle when it is followed by *a mo:tiry*. In the following sentence (3) and (4) show the relative participle-particle relation.

19. *o:n aö öštfoy mo:tiry kĩspini*  
 1 2 3 4 5  
 'I did as he said'

This sentence is derived by embedding the constituent sentence

20. *aö öšči*  
 1 2  
 'he said'  
 1 2

into the matrix sentence

21. *o:n a mo:tiry kĩspini*  
 1 2 3

'I did in that way

1 3 2

The matrix sentence contains *a mo:tiry* 'in that way'. The finite verb *ošči* 'said-he' of the constituent sentence is converted into *ošťoy* 'said (adj.)' when the constituent sentence is embedded into the matrix sentence

<i>o:n</i>	[	<i>aθ</i>	<i>ošči</i> ]	<i>a mo:tiry</i>	<i>kīspini</i>
NP	NP	VP	Adv.	VP	
1	2	3	4	5	

(the constituent sentence is within parenthesis) and this undergoes the following transformational rule.

Relativization transformation

SD:	<i>o:n</i>	<i>aθ</i>	<i>ošči</i>	<i>a mo:tiry</i>	<i>kīspini</i>
	NP	NP	VP	Adv.	VP
	1	2	3	4	5

SC:  $1+2+3+4+5 \Rightarrow 1+2+3\text{-RP}+4+5$

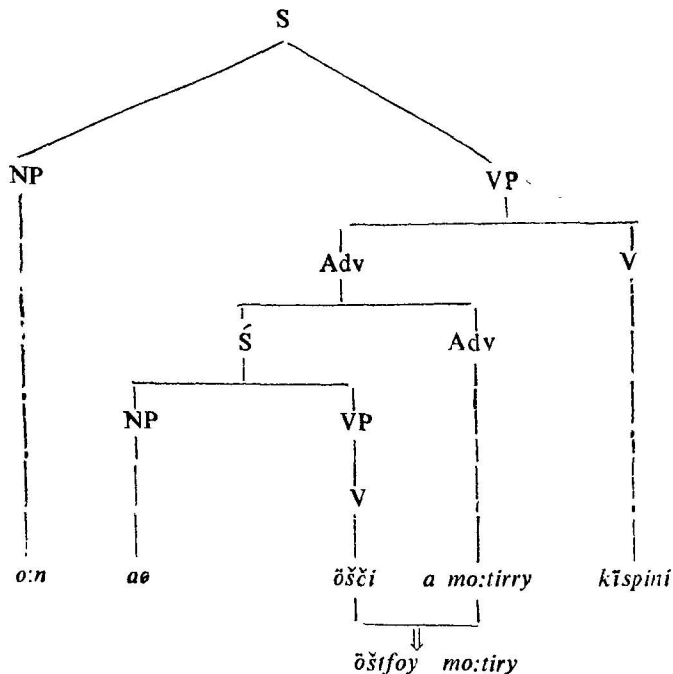

#### 9.2.2.2. *pīn* 'after / afterwards'

In the following sentence,

o:n aθ pi:foy pīn pozpini  
1 2 3 4 5

*pi:foy* is the relative participle and *pīn* 'after / afterwards' is the particle and the phrase *pi:foy pīn* is in construction with the following verb *pozpini* 'came-I'. The tense of the relative participle is conditioned by the particle occurring in embedding sentence. The finite verb of the constituent sentence

is followed by *pīn* 'after/afterwards'. The verb phrase is modified when the particle *pīn* follows it.

*pīn* 'after/afterwards' occurs after past relative participle. The finite verb is converted into relative participle when it is followed by *pīn*. In the following sentence (3) and (4) show the relative participle-particle relation.

22. *o:n aθ pi:foɥ pīn pozpini*  
       1   2     3    4     5  
       'I came after he left'  
       1   5     4    2     3

This sentence is derived by embedding the constituent sentence

23. *aθ pi:či*  
       1    2  
       'He went'  
       1    2

into the matrix sentence

24. *o:n pīn pozpini*  
       1    2     3  
       'I came afterwards'  
       1    3     2

The matrix sentence contains *pīn* 'after/afterwards'. The finite verb *pi:či* 'went-he' of constituent sentence is converted into *pi:foɥ* went (adj.) when the constituent sentence is embedded into the matrix sentence

- o:n [aθ pi:či] pīn pozpini*  
   NP NP   VP Adv. VP  
   1  2   3  4   5

(the constituent sentence is within parenthesis) and this undergoes the following transformational rule.

Relativization transformation

SD : *o:n aθ pi:či pīn pozpini*

NP NP VP Adv. VP

1 2 3 4 5

SC : 1+2+3+4+5 ⇒ 1+2+3-RP+4+5

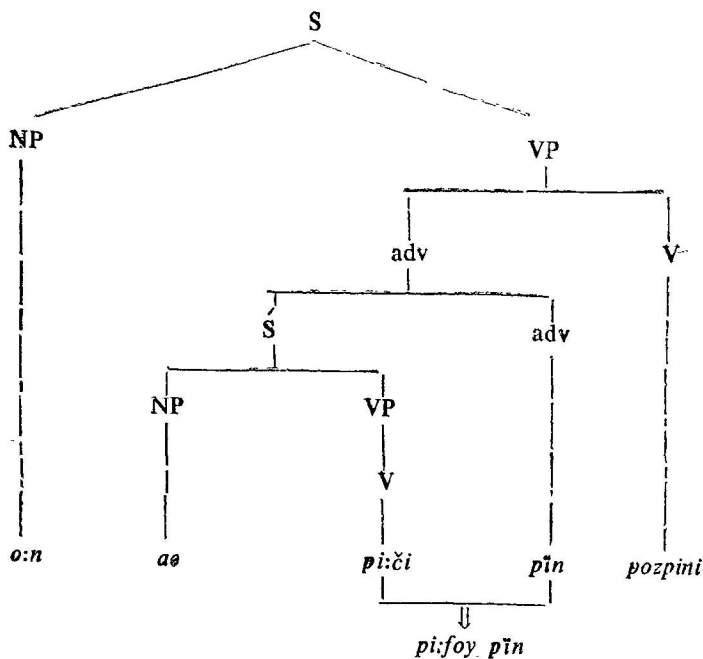

### 9.2.3. Verbal participle

In Toda language there is a verbal category called verbal participle which is used to express action performed by the subject when two or more actions are expressed in a sentence. The participle actions of the subject is always expressed by the finite verbs which always occur after the verbal participles which express the subordinate actions. In English such actions are usually expressed by a series of finite verbs joined by conjunctions. Verbal participle is in construction with the following verb.

Meaning	Form set up in the matrix sentence
1. Object	N + n (Obj.)
2. Consecutive	<i>pīn</i> 'afterwards'
3. Manner	<i>agīs</i> 'in that manner'
4. Causal	<i>aena:l</i> 'because of that'

#### 9.2.3.1 Object N + n (Obj.)

*mutna:s kelcn kīs mutfiči*

'Mutnas did the work and finished'

#### 9.2.3.2. Consecutive *pīn* 'after/afterwards'

*o:n īrn kars pīn pojo:rtk pi:pini*

'having milked the buffalo, I will proceed to Ootacamund afterwards'

#### 9.2.3.3. Manner *agīs* 'in that manner'

*ni: nīloø pī:x*

'you go without standing'

## 9.2.3.4 Causal

*aθ-n-a:l* 'because of that or by that'  
*ak ku:x kurubn nwī:s oʃfiči*  
 'having seen the Kurumba, the girl feared'

## 9.2.3.1. Object

*mutna:s kelcn kīs mutfiči*  
 1 2 3 4  
 'Mutnas did the work and finished'

is obtained from the matrix sentence

*mutna:s kelcn mutfiči*  
 1 2 3  
 'Mutnas has finished the work'

and from the constituent sentence

*mutna:s kelcn kīsči*  
 1 2 3  
 'Mutnas did the work'

When the constituent sentence is embedded into the matrix sentence, the following resultant sentence is gotten.

*mutna:s [mutna:s kelcn kīsči] kelcn mutfiči*  
 1 2 3 4 5 6 7

The following transformational rules are applied.

Verbal participialization transformation

SD: *mutna:s mutua:s kelcn kīsči kelc n mutfiči*  
 NP<sub>i</sub> NP<sub>i</sub> Obj VP NP n VP  
 1 2 3 4 5 6 7



## 9.2.3.2. Consecutive

*o:n* *ɪrn* *kaɾs* *pɪn* *pojo:rtk* *pi:pini*

1 2 3 4 5 6

'having milked the buffalo, I will proceed to

3 2 1 6

Ootacamund afterwards'

5 4

*o:n* *pɪn* *pojo:rtk* *pi:pini*

1 2 3 4

'I will proceed to Ootacamund afterwards'

and the constituent sentence,

*o:n* *ɪrn* *kaɾspini*

1 2 3

'I milked the buffalo'

1 3 2

The constituent sentence is embedded into matrix sentence.

The resultant sentence is

*o:n* [*o:n* *ɪrn* *kaɾspini*] *pɪn* *pojo:rtk* *pi:pini*

1 2 3 4 5 6 7

The following transformation rules are applied.

Verbal participialization transformation

SD: *o:n* *o:n* *ɪrn* *kaɾspini* *pɪn* *pojo:rtk* *pi:pini*

NP<sub>i</sub> NP<sub>i</sub> Obj. VP Adv. Obj. VP

1 2 3 4 5 6 7

SC: 1+2+3+4+5+6+7 ⇒ 1+2+3+4-VP+5+6+7



## 9.2.3.3. Manner

*ni: nīlōø pī:x*

'you go without waiting or standing'

is gotten from the matrix sentence

*ni: agīs pī:x*

'you go in that way'

and the constituent sentence

*ni: nīdōṭi*

'you don't wait or stand'

The constituent sentence is embedded into the matrix and the resultant sentence is

*ni: [ni: nīdōṭi] agīs pī:x*

The following transformation rules are applied.

## Verbal participialization transformation

SD: *ni: ni: nīdōṭi agīs pī:x*

NP<sub>i</sub> NP<sub>i</sub> VP Adv<sub>m</sub> VP

1 2 3 4 5

SC: 1+2+3+4+5 ⇒ 1+2+3-V.P+4+5

## Equi NP deletion transformation

SD: NP<sub>i</sub> + NP<sub>i</sub> + VP + Adv<sub>m</sub> + VP

1 2 3 4 5

SC: 1+2+3-V.P+4+5 ⇒ 1+3+5

if 1=2

(Since 1=2, 2 is deleted)

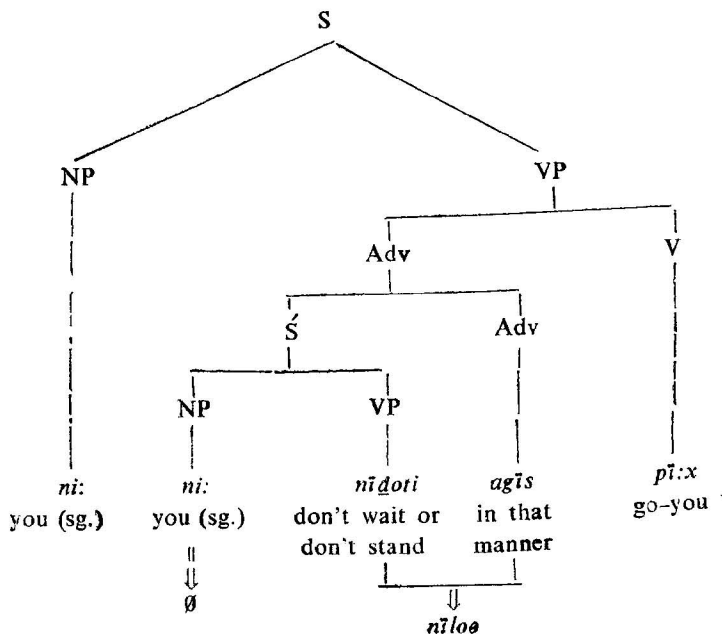

## 9.2.3.4. Causal

*ak ku:x kurubn nwĩ:š oʃfiči*

1 2 3 4

'having seen the Kurumba, the girl feared'

is gotten from the following sentences

*ak ku:x aəna:l oʃfiči*

1 2 3

'she feared because of that'

1     3     2

is the matrix sentence and

*ak ku:x kurubn nwī:či*

1     2     3

'she saw the Kurumbas'

1     3     2

The constituent sentence is embedded into the matrix sentence.

The resultant sentence is,

*ak ku:x [ak ku:x kurubn nwī:či] aəna:l oŋfiči*

The following transformational rules are applied.

Verbal participialization transformation

SD : *ak ku:x ak ku:x kurubn nwī:či aəna:l oŋfiči*

NP	NP	Obj.	VP	Ins.	VP
1	2	3	4	5	6

SC : 1+2+3+4+5+6 ⇒ 1+2+3+4-V.P.+5+6

Equi NP deletion transformation

SD : NP<sub>i</sub> + NP<sub>i</sub> + Obj. + VP + Ins. + VP

1	2	3	4	5	6
---	---	---	---	---	---

SC : 1+2+3+4-V.P.+5+6 ⇒ 1+3+4-V.P.+6

If 1 = 2

(Since 1 = 2, 2 is deleted.)



and bound together at the same level of structural hierarchy by means of a linking device<sup>1</sup>.

In Toda language there are two types of coordinations. They might be called correlative type and non-correlative type. There are three correlative coordinators in Toda. 1) Additive 2) Dubitative and 3) alternative.

In Toda

*mutxe:n pi:či*

1 2

'Mutikan went'

1 2

*ka:wxwītŋ pi:či*

1 2

'Kawkuttan went'

1 2

can be coordinate and the resultant sentence will be

*mutxe:nm ka:wxwītŋm pi:či*

'Mutikan and Kawkuttan went'

Here the noun phrases are coordinated. There is no singular plural distinction in the third person finite verb forms in Toda language. This kind of coordination is possible only when different nouns occur as subjects and the verb is the one and the same. In the following sentence,

*nī:pa:w pi:či*

'Nipaw went'

*pi:tro:jn pi:či*

'Peter Rajan went'

The finite verb *pi:či* is the same

*nī:pa:wm pi:tro:jnm pi:či*

'Nipaw and Peter Rajan went'

1 Simon, C. Dik, *Coordination, its implications for the theory of General Linguistics*, p. 25.

*o:n mutna:š kozpini* 'I saw Mutnas'

*o:n sinmury kozpini* 'I saw Sinmury'

The above sentences are responsible for the following,

*o:n mutna:šm sinmuryym kozpiui*

'I saw Mutnas and Simury'

Here the objects *mu:na:š* and *sinmury* are combined. The conjucative - *m* is added to both the nouns. In this case also, the verb should be one and the same. This can be extended to other grammatical categories also.

The additive construction has the clitic - *m*, dubitative-*isky* and alternative - *oynum* or *em* in the matrix sentences in the deep structure.

### 9.2.5.1. Additive

#### 9.2.5.1.1.

In this type of coordinate construction either the noun phrase or verb phrase can be conjoined. The noun phrases that are conjoined can either be the subject of the sentence or be part of the verb phrase.

*sinmuryym tōwbnīšm pi:či* 'Sinmury and Tebnis went'

is gotten by conjoining the matrix sentences

*sinmury pi:či* 'Simury went'

*tōwbnīš pi:či* 'Tebnis went'

*sinmuṛy* and *tōwbñiṣ* are subjects of the two matrix sentences. The two matrix sentences are conjoined and the resultant sentence will be,

Conj- *sinmuṛy pi:či tōwbñiṣ pi:či*<sup>1</sup>

This undergoes the following transformation rules.

#### Coordination conjoining transformation

SD: Conj- *Sinmuṛy pi:či Tōwbñiṣ pi:či*<sup>1</sup>  
           X      NP      VP      NP      VP  
                   1      2      3      4

SC: X-1+2+3+4  $\Rightarrow$  1-X+2+3-X+4

#### VP Deletion transformation

SD: NP- Conj + VP + NP — Conj + VP  
           1          2      3          4

SC: 1-Conj+2+3-Conj+4  $\Rightarrow$  1-Conj+2+3-Conj.

#### Residue switch rule

SD: NP- Conj + VP + NP — Conj  
           1      2          3

SC: 1-Conj+2+3-Conj  $\Rightarrow$  1-Conj+3-Conj+2

---

1 Unlike in Tamil there is no singular and plural distinction in the third person finite verb forms in Toda language.



9.2.5.1.2. In the following sentence the noun phrases that are conjoined are part of verb phrase.

*o:n pot ĩrm üj kor̄m kwĩṛspini*

1            2            3            4

'I gave ten buffaloes and five calves'

1 4            2            3

is gotten from the matrix sentence

*o:n pot ĩr kwĩṛspini*    'I gave ten buffaloes'

*o:n üj kor̄ kwĩṛspini*    'I gave five calves'

The two matrix sentences are conjoined and the resultant sentence will be,

Conj- *o:n pot ĩr kwĩṛspini o:n üj kor̄ kwĩṛspini*

This undergoes the following transformational rules.

#### Coordination conjoining transformation

SD: Conj- *o:n pot ĩr kwĩṛspini o:n üj kor̄ kwĩṛspini*

X    1    2    3    4    5    6  
       NP Obj<sub>1</sub> VP    NP    Obj.    VP

SC: X-1+2+3+4+5+6 ⇒ 1+2-X+3+4+5-X+6

#### VP Deletion transformation

SD: NP + Obj. -X + VP + NP + Obj. -X + VP

1    2    3    4    5    6

SC: 1+2-X+3+4+5-X+6 ⇒ 1+2-X+3+5-X

#### Residue switch rule

SD: NP + Obj. -X + VP + Obj. -X

1    2    3    5

SC: 1+2-X+3+5-X ⇒ 1+2-X+5-X+3

## SYNTAX

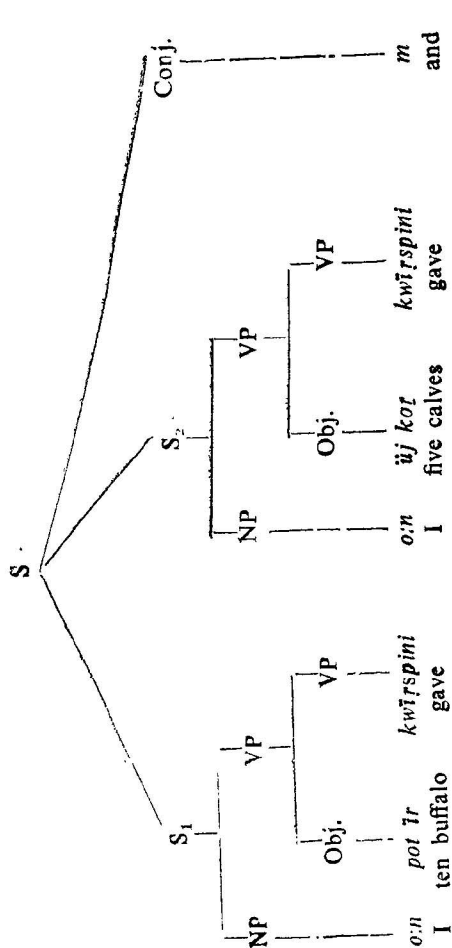

Coordination  
conjoining

Deletion

Residue  
switch  
rule

<i>o:n</i>	<i>potɪrm</i>	<i>kwɪɾspini</i>	<i>üj korɪm</i>	<i>kwɪɾspini</i>
<i>o:n</i>	<i>potɪrm</i>	<i>kwɪɾspini</i>	<i>üj korɪm</i>	<i>kwɪɾspini</i>
<i>o:n</i>	<i>potɪrm</i>	<i>üj korɪm</i>	<i>kwɪɾspini</i>	<i>kwɪɾspini</i>
<i>o:n</i>	<i>potɪrm</i>	<i>üj korɪm</i>	<i>üj korɪm</i>	<i>üj korɪm</i>

9.2.5.1.3. In the following sentences the noun phrases that are conjoined are part of verb phrase.

*sinxe:n pot ĩrm ni:pa:w öt kor̃m mo:r̃či*

‘Sinkan sold ten buffaloes and  
Nipaw sold eight calves’

is gotten from the following matrix sentences

*sinxe:n potĩr mo:r̃či* ‘Sinkan sold ten buffaloes’

*ni:pa:w öt kor̃ mo:r̃či* ‘Nipaw sold eight calves’

The two matrix sentences are conjoined and the resultant sentence will be,

Conj- *sinxe:n potĩr mo:r̃či ni:pa:w ötkor̃ mo:r̃či*

The finite verb *mo:r̃či*<sup>1</sup> ‘sold-he/they’

is the same in both the matrix sentences. Eventhough the subjects are different, the finite verbs are the same.

This undergoes the following transformation rules.

Coordination conjoining transformation

SD: Conj- *sinxe:n potĩr mo:r̃či ni:pa:w öt kor̃ mo:r̃či*  
                  1      2      3      4      5      6

SC: X-1+2+3+4+5+6 ⇒ 1+2-X+3+4+5-X+6

VP Deletion transformation

SD: NP + Obj — X + VP + NP + Obj — X + VP  
          1      2                  3      4                  5      6

SC: 1+2-X+3+4+5-X+6 ⇒ 1+2-X+3+4+5-X

Residue switch rule

SD: NP + Obj — X + VP + NP + Obj — X  
          1      2                  3      4                  5

SC: 1+2-X+3+4+5-X ⇒ 1+2-X+4+5-X+3

1 There is no singular, plural distinction in third person finite verb forms.

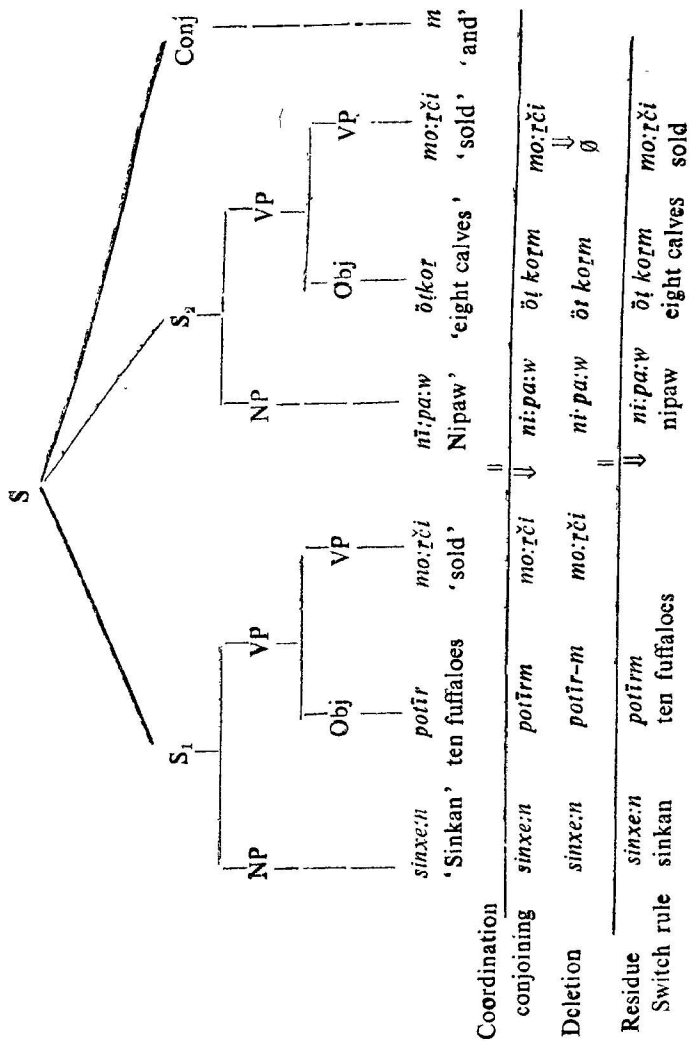

## 9.2.5.2. Dubitative

## 9.2.5.2.1.

*mutna:šisky mutxe:nisky podti*

1                    2                    3

‘either Mutnas or Mutikan will come’

1                    2                    3

is gotten from the following matrix sentences.

1. *mutna:š podti*

2. *mutxe:n podti*

The finite verb *podti* ‘will come-he’ is the same in both the matrix sentences and the subjects are different.

The two matrix sentences are conjoined and the resultant sentence is

Conj.—*mutna:š podti mutxe:n podti*

This undergoes the following transformation rules

Coordination conjoining transformation

SD: Conj. — *mutna:š podti mutxe:n podti*

X                    NP                    VP                    NP                    VP

1                    2                    3                    4

SC:  $X-1+2+3+4 \Rightarrow 1-X+2+3-X+4$

VP Deletion transformation

SD: NP-X + VP + NP-X + VP

1                    2                    3                    4

SC:  $1-X+2+3-X+4 \Rightarrow 1-X+3-X+4$



The two matrix sentences are conjoined and the resultant sentence will be,

Conj- *sinmury pi:ti mutna:s pi:ti*

This undergoes the following transformation rules.

Coordination conjoining transformation

SD: Conj- *sinmury pi:ti mutna:s pi:ti*

X            NP    VP    NP    VP  
              1     2     3     4

SC: X-1+2+3+4  $\Rightarrow$  1-X+2+3-X+4

Deletion transformation

SD: NP- X + VP + NP- X + VP

1            2            3            4

SC: 1-X+2+3-X+4  $\Rightarrow$  1-X+3-X+4

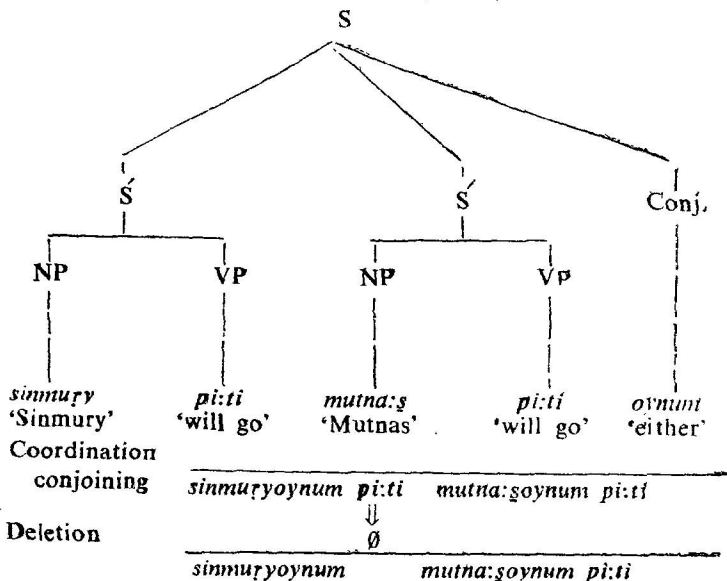

## 9.5.2.4. Non-correlative type

In Toda we have another type of coordinators which are called non-correlative coordinators.

*o:n monšpini e:dīdwīr aθ en ko:tfoy*

‘I forgave because she is  
my wife’

is gotten from the following matrix sentences.

*o:n monšpini*

‘I forgave’

*aθ en ko:tfoy*

‘she is my wife’

The two matrix sentences are conjoined and the resultant sentence is,

Conj- *o:n monšpini aθ en ko:tfoy*

This undergoes the following transformation rules.

Coordination conjoining transformation

SD: Conj- *o:n monšpini aθ en ko:tfoy*

X	NP	VP	NP	GP	NP
---	----	----	----	----	----

1	2	3	4	5
---	---	---	---	---

SC: X-1+2+3+4+5 ⇒ 1+2-X+3+4+5



In the following sentence,

*ni: podfīḍtn o:n koḥpini*

1      2      3      4

'I saw you coming'

3 4      1      2

*podfīḍt-n* 'the act of coming' is a verbal noun which as a verb (Predicate) has its own subject *ni:* you (sg.) and as a noun (Object) it has another verb *koḥpini* 'saw-I' as its predicate. Verbal noun as regular noun can take case markers also.

Verbal noun is derived from the finite verb of the constituent sentence and it is embedded into the noun phrase of the matrix sentence.

Verbal noun occurs as regular nouns and they take all case suffixes.

#### 9.2.6.1. Object

*ni: podfīḍtn o:n koḥpini*

1      2      3      4

'I saw you coming'

3 4      1      2

#### 9.2.6.2. Instrumental

*aḥ pi:fīḍtna:l o:n poḥpini*

1      2      3      4

'I came because of his going'

3 4                      1      2

## 9.2.6.3. Purposive

*tōwbnīs ki:č mo:ryfīđtgo:y pi:či*

1        2            3            4

'Tebnis went for selling the potato'

1            4            3            2

## 9.2.6.4. Subject

*aə pi:fīđt wīl iyi*

1        2        3        4

'it is good that he goes'

4            3            1        2

## 9.2.6.5. Dative

*o:n ko:s kwī:rtfīđtk pozpini*

1        2            3            4

'I came for giving money'

1        4            3            2

## 9.2.6.1. Object

*ni: podfīđtn o:n ko:zpini*

1            2        3        4

'I saw you coming'

3        4        1        2

This sentence is produced by embedding the constituent sentence,

*ni: podpi*

1        2

'you come'

1 2

into the matrix sentence

*o:n an koʒpini*

1 2 3

'I saw it-that'

The resultant sentence is

*o:n [ni: podpi] an koʒpini*

[The constituent sentence is within parentheses]  
and this undergoes the following transformation rules.  
Verbal nominalization transformation

SD: *o:n ni: podpi aθ n koʒpini*  
1 2 3 4 5 6  
NP NP VP PN Obj.Case VP

SC: 1+2+3+4+5+6 ⇒ 1+2+3-VN+4+5+6

Deletion transformation

SD: NP+NP+VP-VN+PN+Obj.C+VP  
1 2 3 4 5 6

SC: 1+2+3-VN+4+5+6 ⇒ 1+2+3-VN+5+6

Permutation transformation

SD: NP+NP+VP-VN+Obj Case+VP  
1 2 3 5 6

SC: 1+2+3-VN+5+6 => 2+3-VN+5+1+6  
which brings 1 between 5 and 6,

we get

*ni: podfīdtn o:n koʒpini*



into the matrix sentence,

*o:n aəna:l pozpini*

1    2    3

'I came because of that'

The resultant sentence is

*oə pi:fīđtna:l o:n pozpini*

The finite verb *pi:ti* is converted into *pi:fīđtna:l* 'because of his going' when the constituent sentence is embedded into the matrix sentence

*o:n [aə pi:ti] aən a:l pozpini*

(The constituent sentence is within parentheses) and this undergoes the following transformation rules.

Verbal nominalization transformation

SD: *o:n aə pi:ti aən a:l pozpini*

1 2 3 4 5 6

NP NP VP PN Ins. VP

SC:  $1+2+3+4+5+6 \Rightarrow 1+2+3-V.N+4+5+6$

Deletion transformation

SD: NP+NP+VP-VN+PN+Ins.+VP

1 2 3 4 5 6

SC:  $1+2+3-VN+4+5+6 \Rightarrow 1+2+3-VN+5+6$

Permutation transformation

SD: NP+NP+VP-VN+Ins.+VP

1 2 3 5 6

SC:  $1+2+3-VN+5+6 \Rightarrow 2+3-V.N+5+1+6$

Then we get,

*oə pī:fīđtna:l o:n pozpini*



## 9.2.6.3 Purposive

*tōwbnī<sub>s</sub> ki:č mo:ryfīđtgo:y pi:či*

1        2        3        4

'Tebnis went for selling potato'

1        4        3        2

This sentence is produced by embedding the constituent sentence,

*tōwbnī<sub>s</sub> ki:č mo:r<sub>t</sub>i*

1        2        3

'Tebnis sells potato'

1        3        2

into the matrix sentence

*tōwbnī<sub>s</sub> aəgo:y pi:či*

1        2        3

'Tebnis went for that purpose'

The finite verb *mo:r<sub>t</sub>i* is converted into *mo:ryfīđtgo:y* 'for selling' when constituent sentence is embedded into the matrix sentence.

The resultant sentence is

*tōwbnī<sub>s</sub> ki:č mo:ryfīđtgo:y pi:či*

*tōwbnī<sub>s</sub> (tōwbnī<sub>s</sub> ki:č mo:r<sub>t</sub>i) aə go:y fī:či*

1        2        3        4        5        6        7

(The constituent sentence is within parentheses) and this undergoes the following transformation rules.





*aə podti*

1 2

'he comes'

1 2

into the matrix sentence

*aə wīl̩ īyi*

'it is good'

The finite verb of the constituent sentence *podti* 'comes-he' is converted into *podfīdt* 'the act of coming' when the constituent sentence is embedded into the matrix sentence.

The resultant sentence is

*aə podfīdt wīl̩ īyi* 'it is good that he comes'

(*aə podti*) *aə wīl̩ īyi*

1 2 3 4 5

(The constituent sentence is within parentheses) and this undergoes the following transformation rules.

Verbal nominalization transformation

SD: *aə podti aə wīl̩ īyi*

1 2 3 4 5

NP VP NP Adv. VP

SC:  $1+2+3+4+5 \Rightarrow 1+2-VN+3+4+5$

Deletion transformation

SD: NP + NP - VN + NP + Adv. + VP

1 2 3 4 5

SC:  $1+2-VN+3+4+5 \Rightarrow 1+2-VN+4+5$

Then we get,

*aə podfīdt wīl̩ īyi*



The finite verb of the constituent sentence *kaṭti* 'learns-he' is converted into *kaṭfīḍtk* 'for learning' when the constituent sentence is embedded into the matrix sentence.

The resultant sentence is

*pō:ṛmox (pō:ṛmox o:ḫ fo:š kaṭti) aḥk podti*

(The constituent sentence is within parentheses) and this undergoes the following transformational rules.

#### Verbal nominalization transformation

SD : *pō:ṛmox pō:ṛmox o:ḫ fo:š kaṭti aḥ k podti*  
           1          2          3      4      5          6      7  
           NP          NP      Obj   VP   Pn. Dat.case  VP

SC : 1+2+3+4+5+6+7 => 1+2+3+4-VN+5+6+7

#### Deletion transformation

SD :. NP + NP + Obj. + VP-VN + Pn. + Dat. + VP  
           1      2      3          4          5      6      7

SC : 1+2+3+4VN+5+6+7 => 1+2+3+4-VN+6+7

#### Equi NP Deletion transformation

SD : NP<sub>i</sub> + NP<sub>i</sub> + Obj. + VP-VN + Case + VP  
           1          2          3          4          6      7

SC : 1+2+3+4-VN+6+7 => 1+3+4-VN+6+7

If 1=2

(Since 1=2, 2 is deleted.)

we get,

*pō:ṛmox o:ḫ fo:š kaṭfīḍtk podti*



Conditional is in construction with the following verb

*aə podnwīṛ o:n pi:pini*

1      2      3      4

'I will go if he comes'

3      4      1      2

*podn-wīṛ* 'if comes' is conditional and it is in construction with the verb *pi:pini* 'will go-I'. Also in the following sentence

*aə po:rofoynwīṛ o:n pī:xeni*

'I won't go if he does not come'

Here *po:rofoynwīṛ* 'if does not come' is conditional and it is in construction with the verb *pī:xeni* 'won't go-I'.

In the above sentences *wīṛ* is the conditional suffix.

#### 9.2.7.1. Affirmative conditional

*sinxe:n podnwīṛ o:n pojo:rtk pi:pini*

1      2      3      4      5

'I will go to Ootacamund if Sinkan comes'

3      5                      4                      1      2

This sentence is produced by embedding the constituent sentence

*sinxe:n podti*

1      2

'Sinkan will come'

1      2

into the matrix sentence

*o:n atfok pojo:rtk pi:pini*

1 2 3 4

'Then I will go to Ootacamund'

2 1 4 3

The matrix sentence contains *atfok* 'then' and the predicate is always non-past. The finite verb of the constituent sentence *podti* 'will come-he' is converted into *podnwĩr* 'if comes', when the constituent sentence is embedded into the matrix sentence.

*o:n (sinxe:n podti) atfok pojo:rtk pi:pini*

(The constituent sentence is within parentheses) and this undergoes the following transformational rules.

Conditional transformation

SD: *o:n sinxe:n podti atfok pojo:rtk pi:pini*

1 2 3 4 5 6

NP NP VP Adv. Dat. VP

SC: 1+2+3+4+5+6 => 1+2+3-Cond.+4+5+6

Adv. Deletion transformation

SD: NP+NP+VP-Cond.+Adv.+Dat.+VP

1 2 3 4 5 6

SC: 1+2+3-Cond.+4+5+6 => 1+2+3-Cond.+5+6

## Permutation transformation

SD : 1+2+3-Cond.+5+6

SC : 1+2+3-Cond+5+6 => 2+3+1+5+6  
which brings 1 between 3 and 5

Then we get,

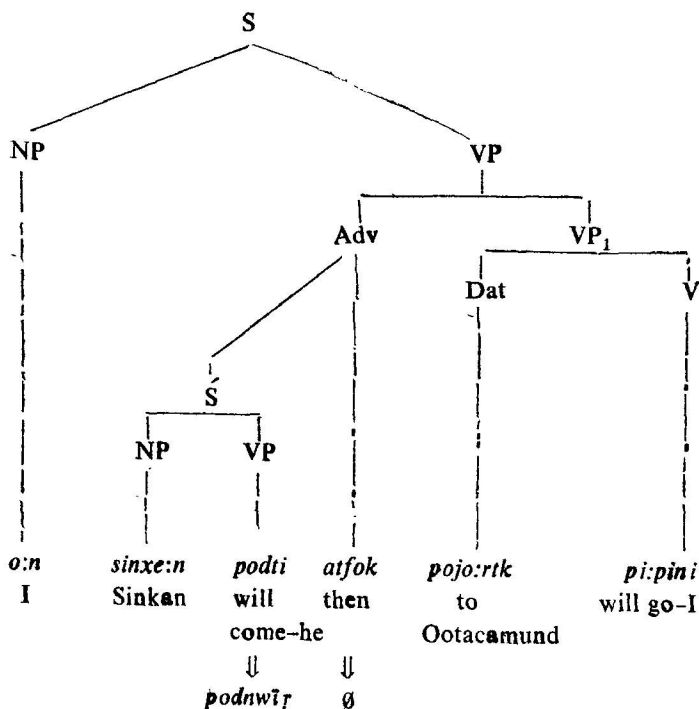
*sinxe:n podnwĩr o:n pojo:rtk pi:pini*



Adv. deletion transformation

SD: NP+NP+VP-Cond.+Adv.+VP  
 1 2 3 4 5

SC: 1+2+3-Cond.+4+5 => 1+2+3-Cond.+5

Permutation transformation

SD: NP+NP+VP-Cond.+VP  
 1 2 3 5

SC: 1+2+3-Cond +5 => 2+3-Cond.+1+5

Then we get,

*oŋon po:rofoynwīŋ wīŋfed podti*

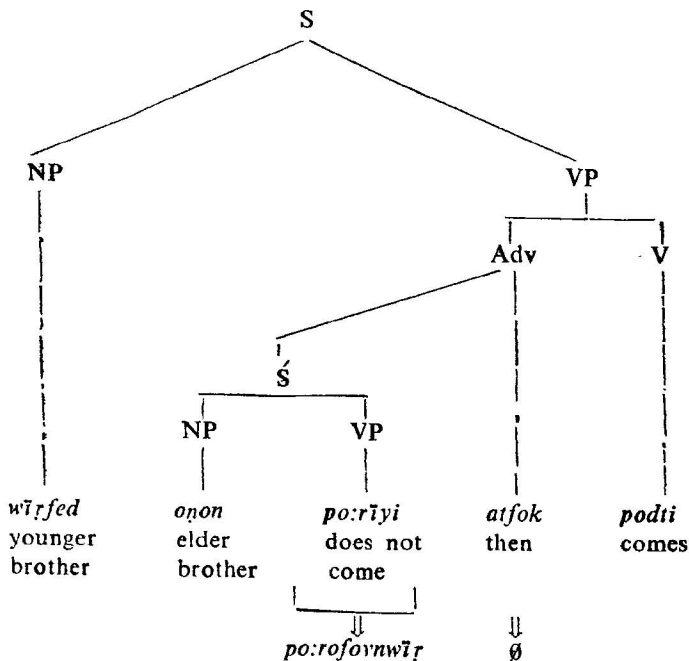

## 9.2.7.2.2.

*mutxe:n öštofoynwīř sinmury po:rīyi*

1            2            3            4

'if Mutikan does not say Sinmury won't come'

1            2            3            4

This sentence is produced by embedding the constituent sentence

*mutxe:n öštīyi*

1            2

'Mutikan does not say'

1            2

into the matrix sentence

*sinmury atfok po:rīyi*

1            2            3

'Sinmury won't come then'

The finite verb of the constituent sentence *öštīyi* 'does not say' is converted into *öštofoynwīř* 'if does not say' when the constituent sentence is embedded into the matrix sentence.

*sinmury [mutxe:n po:rīyi] atfok po:rīyi*

(The constituent sentence is within parentheses) and this undergoes the following transformational rules.

Conditional transformation

SD : . *sinmury mutxe:n öštīyi atfok po:rīyi*

1            2            3            4            5  
NP          NP          VP          Adv.          VP

SC : 1+2+3+4+5 => 1+2+3-Cond+4+5

Adv. deletion transformation

SD: NP+NP+VP-Cond +Adv.+VP  
 1 2 3 4 5

SC: 1+2+3-Cond.+4+5 => 1+2+3-Cond.+5

Permutation transformation

SD: 1+2+3-Cond+5

SC: 1+2+3-Cond+5 => 2+3+1+5

which brings 1 between 3 and 5

Then we get,

*mutxe:n öštofoynwīṛ sinnuṛy po:rīyi*

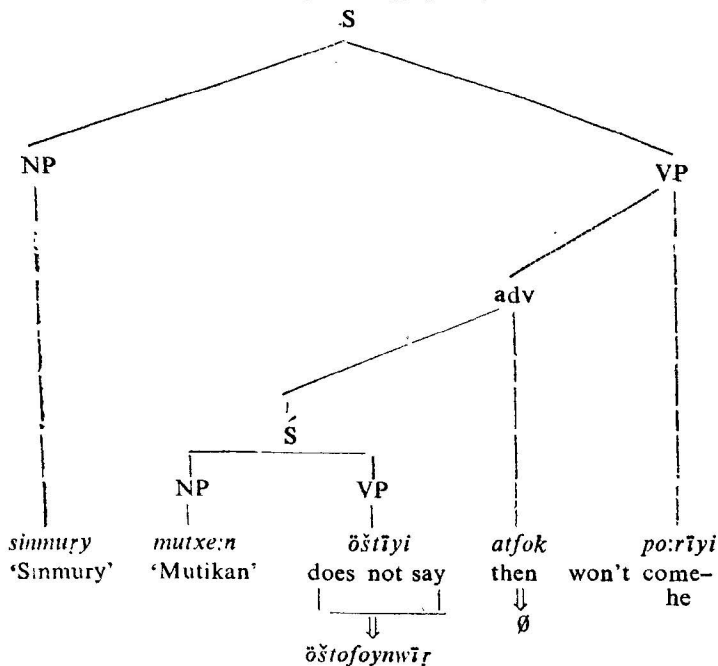

## 9.2.8. Participial noun [P. N.]

For the structure of participial noun (See 4.14)

Participial noun in Toda as in other Dravidian languages is derived from the relative participle and noun. So, all the relations that exist between the relative participle and the following noun are also found here. In Tamil *vantavan* 'one who came' is a participial noun derived from the relative participle, *vanta* 'came' and the pronoun *avan* 'that-he' whereas in Toda there is no gender distinction in third person like Tamil *avan*, *avaḷ* and *adu*. Participial noun is gotten from relative participle + *o:ḷ*.

The structure is

$S_2 + R.P + o:ḷ$

Ex. $kīs + p + \emptyset + o:ḷ$	$=>$	$kīspo:ḷ$	'person who does'
$pod + p + \emptyset + o:ḷ$	$=>$	$podpo:ḷ$	'person who comes'
$kwīṛt + p + \emptyset + o:ḷ$	$=>$	$kwīṛtpo:ḷ$	'person who gives'
$kīs + \emptyset + foy + o:ḷ$	$=>$	$kīsfoyo:ḷ$	'person who did'
$pi: + \emptyset + foy + o:ḷ$	$=>$	$pi:foyo:ḷ$	'person who went'
$tīḍ + \emptyset + foy + o:ḷ$	$=>$	$tīḍfoyo:ḷ$	'person who ate'

## 9.3. Singularly transformations

"In many natural languages we find changes of order among various constituents of sentences, deletion of certain constituents, additions of certain items etc. and they are taken care of by certain transformations which are known as Singularly transformations"<sup>1</sup>. The singularly transformations take

1 S. Agesthalingom, *A Generative Grammar of Tamil*, p. 109.

place within simple sentences and there are three kinds of transformations, viz, permutation, replacement and deletion. In Toda language we find certain changes in the order of various constituents and they are dealt with here.

### 9.3.1. Permutation

9.3.1.1. Opt.NP+Case+V => Case+NP+V

*o:n an koʒpini*  
 1 2 3  
 'I saw him'  
 => *a:n o:n koʒpini*  
 2 1 3

9.3.1.2. Opt.NP+Tm+V => Tm+NP+V

*tōwbñīš mune:r pi:či*  
 1 2 3  
 'Tebnis went day before yesterday'  
 => *mune:r tōwbñīš pi:či*  
 2 1 3

9.3.1.3. Opt.NP+Abl.+V => Abl.+NP+V

*o:n mođšn pozpini*  
 1 2 3  
 'I came from mund'  
 => *mođšn o n pozpini*  
 2 1 3

9.3.1.4 Opt.NP+Soc.+V => Soc.+NP+V

*o:n anpođy pi:špini*  
 1 2 3  
 'I went with him'  
 => *anpođy o:n pi:špini*  
 2 1 3

## 9.3.1.5. Opt.X+Y+Temp.+V =&gt; Y+Temp.+X+V

*o:n aθ podfok pi:špini*

1 2 3 4

'I went when he came'

=> *aθ podfok o:n pi:špini*

2 3 1 4

## 9.3.1.6 Rel.part+X+Y+Copula =&gt; Y+Rel.part+X+Copula

*uđt ni:r iθ iyi*

1 2 3 4

'This is drinking water'

=> *iθ uđt ni:r iyi*

3 1 2 4

## 9.3.1.7 Opt.NP+Purp.+Adv.+V

*aθ aego:y a:nk pi:či*

1 2 3 4

'he went for that purpose'

=> NP+Adv.+Purp.+V

*aθ a:nk aego:y pi:či*

1 3 2 4

and

Adv.+NP+Purp.+V

*a:nk aθ aego:y pi:či*

3 1 2 4

## 9.3.1.8. Opt.NP+Purp.+Dat.+V

*mutna:s aego:y pojo:rtk pi:či*

1 2 3 4

'Mutnas went to Ootacamund for that purpose'

=> NP + Dat. + Purp. + V

*mutna:ḡ pojo:rtk aəgo:y pi:či*  
 1        3        2        4

=> Purp. + NP + Dat + V.

*aəgo:y mutna:ḡ pojo:rtk pi:či*  
 2        1        3        4

=> Dat. + Purp. + NP + V

*pojo:rtk aəgo:y mutna:ḡ pi:či*  
 3        2        1        4

and

Dat. + NP + Purp. + V

*pojo:rtk mutna:ḡ aəgo:y pi:či*  
 3        1        2        4

### 9.3.2. Deletion

#### 9.3.2.1. Num. + Case + Num. + NP + V

*wīḍ u:rḡ wīḍ ro:jn wīḍy*  
 1    2    3    4    5

'there was a king in a country'

=> Num + Case + Num + NP

*wīḍ u:rḡ wīḍ ro:jn*  
 1    2    3    4

#### 9.3.2.2. Dem. Adj. + Case + Num. + NP + V =>

Dem. Adj + Case + Num. + NP

*a ro:jnk wīḍ tojmox wīḍy*  
 1    2    3    4    5

=> *a ro:jnk wīḍ tojmox*

1    2    3    4

$$9.3.2.3. \text{ Pn} + \left\{ \begin{array}{c} \text{NP} \\ \text{VP} \end{array} \right\} = > \left\{ \begin{array}{c} \text{NP} \\ \text{VP} \end{array} \right\}$$

*o:n pozpini => pozpini*

'I' 'came' 'came'

1 2 2

*iə en a:s => en a:s*

'this(is) my house' 'my house'

1 2 3 2 3

*iə ogodykub mu:ʃɪr => ogodykub mu:ʃɪr*

'this(is) Kotagiri bus' 'kotagiri bus'

1 2 3 2 3

'this is Kotagiri bus'

*iə kwa:ymütu:r ɪr => kwa:ymütu:r ɪr*

'this(is) Coimbatore buffalo' 'Coimbatore buffalo'

1 2 3 2 3

'this is Coimbatore buffalo'

*iə kaɾno:ʃ ɪr => kaɾno:ʃ ɪr*

'this(is) Mysore buffalo' 'Mysore buffalo'

1 2 3 2 3

'this is Mysore buffalo'

## 9.3.3. Replacement

9.3.3.1. Opt.

Dat.  Loc.	=>	$\left\{ \begin{array}{l} a:nk \\ i:nk \end{array} \right\}$  $\left\{ \begin{array}{l} al \\ il \end{array} \right\}$
------------------	----	--

*sinmury moɾtk pi:ti*

1          2          3

‘Sinmury goes to the mund’

=> *sinmury a:nk pi:ti*

‘Sinmury goes there’

*sinxe:n pojo:rtk podti*

1          2          3

‘Sinkan comes to Ootacamund’

=> *sinxe:n i:nk podti*

‘Sinkan comes here’

*ko:ltmox poɟyʃ wīɟy*

1          2          3

‘dairy boy is in the temple or dairy’

=> *ko:ltmox il wīɟy*

‘dairy boy is here’

*ay o:ɟ kwa:ɾʃ wīɟy*

1   2   3   4

‘that man is in the forest’

=> *ay o:ɟ al wīɟy*

‘that man is there’

9.3.3.2. Opt. Tm -a: => *etfok*

*sinxe:n noʔpoxol-a: pi:či*  
=> *sinxe:n etfok pi:šk?*  
'when did Sinkan go?'

*mutna:s ekaʔfotk-a: pi:či*  
=> *mutna:s etfok pi:šk?*  
'when did Mutnas go?'

*sinkijpu:f üjmoŋyk-a: pi:či*  
=> *sinkijpu:f etfok pi:šk?*  
'when did Sinkijpuf go?'

*mutxe:n mu:dmoŋyk-a: pi:či*  
=> *mutxe:n etfok pi:šk?*  
'when did Mutikan go?'

or

'at what time did Mutigan go?'

9.3.3.3. Opt.  $\left\{ \begin{array}{c} T_1 \\ T_2 \end{array} \right\}$  -a: => *etfīn*

*mune:r-a: => etfīn*  
*mutxe:n etfīn pozk?*  
'on which day did Mutikan come?'

*īne:r-a: => etfīn*  
*na:nxe:n etfīn pozk?*  
'on which day did Nanikan come?'

*īd-a: => etfīn*  
*sinkijpu:f etfīn pozk?*  
'on which day did Sinkijpuf come?'

*makolk-a:* => *etfīn*

*mutna:ḡ etfīn podu?*

‘on which day will Mutikan come?’

9.3.3.4.  $\left\{ \begin{array}{l} a:nk \\ i:nk \\ N-\check{s} \\ N-k \end{array} \right\} -a: \Rightarrow \left\{ \begin{array}{l} e:nk \\ e:l \end{array} \right\}$

*a:nk-a:* => *e:nk*

*aə e:nk pi:u?*

‘where does he go?’

*i:nk-a:* => *e:nk*

*sinkijpu:f e:nk podu?*

‘where does he come?’

*poṭyš-a:* => *e:l*

*aə e:l wīḍy?*

‘where is it?’

*pojo:rtk-a:* => *e:nk*

*aə e:nk pi:šk?*

‘where did he go?’

9.3.3.5. Opt.NP+N<sub>1</sub>-Acc.-Conj.+N<sub>2</sub> = Acc.-Conj.+V  
=> NP+PNpl.-Acc.+V

*o:n sinmury-n-m mutna:ḡ-n-m koḡpini*  
1            2                    3                    4

‘I saw Sinmury and Mutnas’

=> *o:n aəa:n koḡpini*

I Pnpl 4

‘I saw them’

# Bibliography

Agesthialingom, S.

- 1961 *Description of the language of Patirrupattu with Transliteration, Translation and Index*, Ph. D. Dissertation, Kerala University.
- 1967 *A Generative Grammar of Tamil [A fragment of Tamil Syntax]*, Annamalai University, Annamalainagar.
- 1969 "Transitive and Intransitive verbs", *All India Oriental Conference, XXV Session*, Calcutta.
- 1971 "A note on Tamil verbs" *Anthropological Linguistics*, 13, 4, 121-25, Bloomington.
- 1971 "Modality in Tamil", *Second All India Conference of Linguists*, Delhi.

Agesthialingom, S.

1972 "Nouns of the Badaga language", *Journal of the American Oriental Society*, 92, 2, 276-79.

1976 *Kanikkara Dialect*, Annamalai University, Annamalainagar.

Agesthialingom, S.

and

Kumaraswamy Raja, N.

1969 [Eds.] *Dravidian Linguistics, [Seminar Papers]*  
Annamalai University, Annamalainagar.

Agesthialingom, S.

and

Sakthivel, S.

1970 "Toda phonology", *Journal of Annamalai University [Humanities]*, Vol. XXVII, 131-68,  
Annamalainagar.

1972 "Toda nouns", *Indian Linguistics*, Vol 33, 2, 153-57  
Poona.

1976 "Ethnographic study of the Todas of Nilgiri Hills,"  
*Bulletin of the Institute of Traditional Culture*,  
University of Madras, Madras.

Agesthialingom, S.

and

Shanmugam, S. V.

1970 *The Language of Tamil Inscriptions [1250-1350 A.D.]*  
Annamalai University, Annamalainagar.

1972 [Eds.] *Third Seminar on Dravidian Linguistics*,  
Annamalai University, Annamalainagar.

Aiyappan, A.

- 1948 *Report on the Socio-economic conditions of the Aboriginal Tribes of the Province of Madras, Madras.*

Andronov, M.

- 1970 *Dravidian Languages*, Nauka Publishing House, Moscow.

Bloch, J.

- 1946 *Structure grammaticale des langues Dravidiennes*, Paris [Eng. tr. by Harshe, R. G. Poona, 1954.]

Brecks, J. W.

- 1873 *An account of the Primitive Tribes and monuments of the Nilgiris*, London.

Bright, W.

and

Lingenfeld, J.

- 1968 "Complex verb forms in Colloquial Tamil", *Studies in Indian Linguistics*, Ed. Bh. Krishnamurti, Poona and Annamalainagar.

Burrow, T.

- 1968 *Collected papers on Dravidian Linguistics*, Annamalai University, Annamalainagar.

Burrow, T.

and

Emeneau, M. B.

- 1961 *A Dravidian Etymological Dictionary [DED]*, Oxford.
- 1967 *A Dravidian Etymological Dictionary: Supplement [DEDS]*, Oxford.

Caldwell, R.

- 1956 *A Comparative Grammar of the Dravidian or South-Indian family of languages*, [3rd ed. Revised and edited by the R. J. L. Wyatt and T. Ramakrishna pillai, reprinted], Madras.

Dik, S. C.

- 1968 *Coordination, its implications for the theory of General Linguistics*, Amsterdam.

Emeneau, M. B.

- 1957 "Toda, a Dravidian language", *Transactions of the Philological Society*, 15-66, London.

- 1966 "Some South Dravidian noun formatives", *Indian Linguistics*, 27, 21-30, Poona.

- 1967 "The South Dravidian Languages", *Journal of the American Oriental Society*, 87, 4, 365-413.

- 1967 *Dravidian Linguistics, Ethnology and Folk tales, Collected papers*, Annamalai University, Annamalai-nagar,

- 1970 *Dravidian Comparative Phonology, A Sketch*, Annamalai University, Annamalainagar.

- 1971 *Toda Songs*, Oxford.

Grierson, G. A.

- 1906 *Linguistic Survey of India*, Vol. IV [Munda and Dravidian languages], Calcutta.

Grigg, H. B.

- 1880 *A Manual of the Nilgiri District in the Madras Presidency*.

Gundert, A.

1962 *Malayala Bhāṣavyakaraṇam*, Kottayam.

Jacobs, A. Roderick

and

Rosenbaum, S. Peter

1968 *English Transformational Grammar*, Blaisdell  
Publishing Company

Kothandaraman, P.

1970 A Contrastive analysis of Tamil and Telugu. [A  
transformational approach], Ph. D. Dissertation,  
Annamalai University, Annamalainagar.

Krishnamurti, Bh.

1968 "Dravidian Personal Pronouns", *Studies in Indian  
Linguistics*, Ed. Bh. Krishnamurti, 189-205, Poona  
and Annamalainagar.

Kumaraswami Raja, N.

1969 *Post-Nasal Voiceless Plosives in Dravidian*, Annamalai  
University, Annamalainagar.

Mandelbaum, D. G.

1941 "Culture change among the Nilgiri tribes",  
*American Anthropologist*, 43.

Marshall, William, E.

1873 *A Phrenologist amongst the Todas*, Longmans,  
Green & Co., London.

Metz, J. F.

1875 "A Vocabulary of the dialect spoken by the Todas  
of the Nilgiri mountains", *Madras Journal of  
Literature and Science*, 1, 2, 1-24.

Nambiar, P.

1965 *Census of India, 1961, Todas*, Vol. XI, Delhi.

Oppert, G. S.

1896 "Ueber die Toda and Kota in den Nilgiri oder den blanen", *Bergen, Zeitschrift für Ethnologie*, 28, 213-21

Peter, Prince of Greece

1951 *Possible Sumerian Survivals in Toda Rituals*, Bulletin of the Madras Government Museum, Madras.

Pope, G. U.

1873 "A Brief outline of the Grammar of the Tuda language", In Marshall's *A Phrenologist amongst the Todas*, 239-69, London.

Rivers, W. H. R.

1906 *The Todas*, London.

Sakthivel, S.

1971 "A contrastive study of Tamil and Toda", *Psycho-Lingua*, 1, 1, 1-12, Raipur.

1971 "The Todas and Sumerian relationship: A critical study", *Ayvuk Kovai*, 55-55, Annamalainagar.

1972 "Dravidian vowel system", Fourth All India University Tamil Teacher's Conference Seminar, 353-48, Trivandrum.

1974 "Toda case system", *Seminar on Dravidian Case System*, Annamalai University, Annamalainagar.

Sakthivel, S.

- 1974 "A Contrastive study of Toda and Kota", *Silver Jubilee Volume of the Annals of the Oriental Research*, University of Madras, Madras.
- 1974 "Area Study: Nilgiris", *Prof. Thirugnanasambandam Commemoration Volume*, Madras.
- 1976 *Tribal Languages of India*, Navalar Puthaka Nilayam, Madurai.
- 1976 *Phonology of Toda with Vocabulary*, Annamalai University, Annamalainagar.
- 1976 "Nilgiris: A Tribal Linguistic Area", *Indian Journal of Linguistics - Prof. Sunitikumar Chatterjee Felicitation Volume*, Calcutta.

Schmid, Bernhard

- 1837 "Of the dialect of the Todavars, the aborigines of the Neilgherries," *Madras Journal of Literature and Science*, 5, 155-58.

Shanmugam, S. V.

- 1968 *The Language of the Tamil Inscriptions [1350 to 1700 A.D.]*, Ph.D. Dissertation, Annamalai University
- 1971 *Dravidian Nouns [A Comparative Study]*, Annamalai University, Annamalainagar.

Shortt, J.

- 1868 *An account of the tribe on the Neilgherries*, Madras.

Subbiah, G.

- 1972 *A Descriptive study of Kota language*, Ph. D. Dissertation, Annamalai University.

Subrahmanyam, P. S.

- 1968 *A Descriptive Grammar of Gondi*, Annamalai University, Annamalainagar.

- 1971 *Dravidian Verb Morphology [A Comparative Study]* Annamalai University, Annamalainagar.

Ward, B. S.

- 1880 *Manual of Nilgiri District*.

Winfield, W. W.

- 1928 *A Grammar of the Kui Language*, Calcutta.

Zvelebil, K.

- 1970 *Comparative Dravidian Phonology*, Mouton, The Hague, Paris.



# ANNAMALAI UNIVERSITY

## DEPARTMENT OF LINGUISTICS PUBLICATIONS

—o—

1961

1. *Prof T. P. Meenakshisundaran Sixty-first  
Birth day Commemoration Volume* Rs. 3-75  
Collected papers of Prof. T. P. Meenakshisundaran
2. *Kolami, a Dravidian Language* Rs 11-50  
M. B. Emeneau

1965

3. *History of Tamil Literature* Rs. 10-00  
T. P. Meenakshisundaran
4. *Spoken Tamil I* Rs. 6-65  
M. Shanmugam Pillai
5. *India and Historical Grammar* Rs. 4-00  
M. B. Emeneau
6. *Lexicography* Rs. 4-00  
S. M. Katre
7. *Dravidian* Rs. 4-00  
S. K. Chatterji

1966

8. *Conversational Tamil* Rs. 7-00  
N. Kumaraswami Raja and  
K. Doraswamy

1967

9. *Dravidian Linguistics, Ethnology and  
Folk-Tales—Collected papers* Rs. 25-00  
M. B. Emeneau

10. *Naccinarkkiniyar's Conception of Phonology* Rs. 5-00  
S. V. Shanmugam
11. *A Generative Grammar of Tamil (A fragment of Tamil Syntax)* Rs. 7-00  
S. Agesthialingom
- 1968
12. *Spoken Tamil II* Rs. 6-66  
M. Shanmugam Pillai
13. *Collected Papers on Dravidian Linguistics* Rs. 8-00  
T. Burrow
14. *A Modern Evaluation of Nannu:l* Rs. 8-00  
G. Vijayavenugopal
15. *Two Lectures on the Historicity of Language Families* Rs. 1-50  
M. Andronov
16. *A Descriptive Grammar of Gondi* Rs. 5-00  
P. S. Subrahmanyam
- 1969
17. *Dravidian Linguistics (Seminar papers)* Rs. 7-00  
(Eds.) S. Agesthialingom and  
N. Kumaraswami Raja
18. *Post-Nasal Voiceless Plosives in Dravidian* Rs. 3-00  
N. Kumaraswami Raja
19. *The Tirunelveli Tamil Dialect* Rs. 5-00  
A. Kamatchinathan
- 1970
20. *Gowda Kannada* Rs. 3-60  
K. Kushalappa Gowda

21. *Vaagri Boli: An Indo-Aryan Language* Rs. 5-00  
G. Srinivasa Varma
22. *Dravidian Comparative Phonology: A Sketch* Rs. 6-00  
M. B. Emeneau
23. *The Language of Tamil Inscriptions  
1250-1350 A.D.*  
S. Agesthialingom and Rs. 5-00  
S. V. Shanmugam

1971

24. *Dravidian Verb Morphology (A Comparative  
Study)* Rs. 10-00  
P. S. Subrahmanyam
25. *Dravidian Nouns (A Comparative Study)* Rs. 8-00  
S. V. Shanmugam
26. *The Kollimalai Tamil Dialect* Rs. 6-00  
K. Karunakaran

1972

27. *Third Seminar on Dravidian Linguistics* Rs. 10-00  
(Eds.) S. Agesthialingom and  
S. V. Shanmugam
28. *A Grammar of Kannada (based on the  
inscriptions of Coorg, South Kanara and  
North Kanara Dts. 1000-1400 A. D.)* Rs. 10-00  
K. Kushalappa Gowda
29. *Tolka:ppiya moliyial (Collection of papers-  
presented at the Seminar on Tolka:ppiyam)* Rs. 10-00  
(Eds.) S. Agesthialingom and  
K. Murugaiyan

## 1973

30. *A Bibliography of Dravidian Linguistics* Rs. 10-00  
S. Agesthialingom and  
S. Sakthivel
31. *A Bibliography for the study of  
Nilagiri Hill Tribes* Rs. 2-00  
S. Agesthialingom and  
S. Sakthivel
32. *Structure of Malto* Rs. 5-00  
Sisir Kumar Das

## 1974

33. *Contrastive Linguistics and Language Teaching* Rs. 10-00  
K. Theivanantham Pillai
34. *An Introduction to Modern Telugu* Rs. 10-00  
P. S. Subrahmanyam
35. *Ilakkana a:yvukkatturaikal-I* Rs. 10-00  
(Eds.) S. Agesthialingom and  
K. Balasubramanian

## 1975

36. *Cuva:mina:tam* ...  
(Ed.) S. V. Shanmugam
37. *Nominal Composition in Malayalam* ...  
(A Generative Transformational Approach)  
P. N. Ravindran
38. *Linguistic Diversity* ...  
M. W. S. De Silva
39. *Dravidian Case System* **1976** ...  
(Eds.) S. Agesthialingom and  
K. Kushalappa Gowda

40. *Phonology of Kodagu with Vocabulary* ...  
R. Balakrishnan
41. *Phonology of Toda with Vocabulary* ...  
S. Sakthivel
42. *Cuva:mina:tha mu:lamum virutti uraiyum.* ...  
(Ed.) S. V. Shanmugam
43. *Four Lectures on Paṇini* ...  
H. S. Ananthanarayana ...
44. *Phonology of Kasaba with Vocabulary* ...  
V. Chidambaranatha Pillai
45. *Kanikkara Dialect* ...  
S. Agesthialingom
46. *Saiva Vellala Tamil Dialect* ...  
K. Karunakaran and  
C. Shanmugam Pillai
47. *Dravidian Linguistics-V* ...  
(Eds.) S. Agesthialingom and  
P. S. Subrahmanyam
48. *Harijan Dialect of Tamil (South Arcot)* ...  
G. Srinivasa Varma and  
N. Ramaswami

49. *A Grammar of the Toda Language*  
S. Sakthivel  
(FORTHCOMING)
50. *A Descriptive Grammar of Patirrupattu-I*  
S. Agesthialingom
51. *A Descriptive Grammar of Patirrupattu-II*  
S. Agesthialingom
52. *A Grammar of Kodagu*  
R. Balakrishnan
53. *Studies in Early Dravidian Grammars*  
(Eds.) S. Agesthialingom and  
N. Kumaraswami Raja
54. *Dravidian Comparative Phonology*  
P. S. Subrahmanyam

